

鑽石工具系列

Diamond File Series

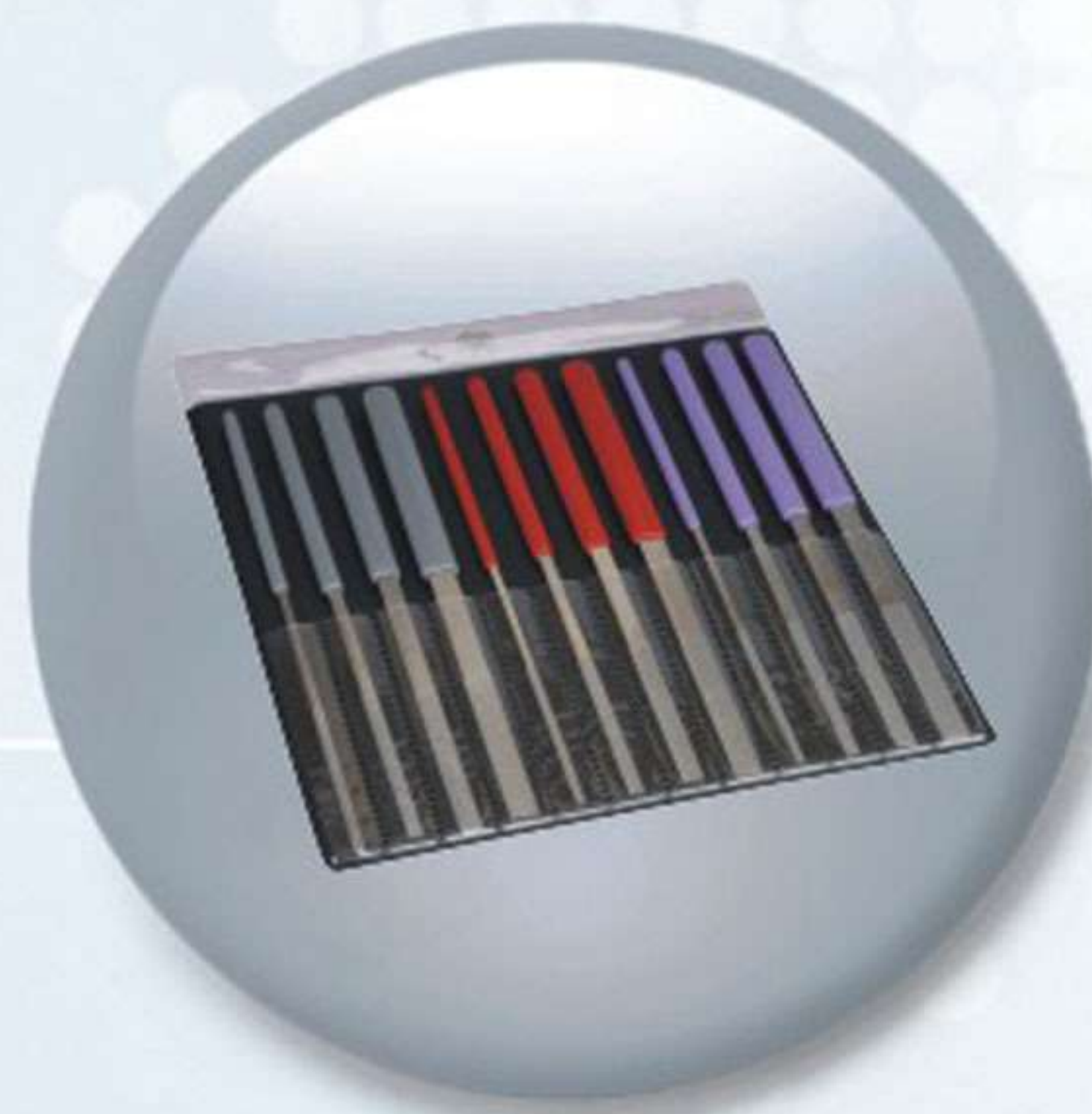

纖維油石、EDM油石
Fiber Stones/EDM Stones



鑽石銼刀
Diamond Files



鑽石修刀
Diamond Dressers



鑽石磨棒
Diamond Burrs



鎢鋼滾磨刀
Solid Carbide



棕刷、帶柄砂輪
Brush/Grinding Pins

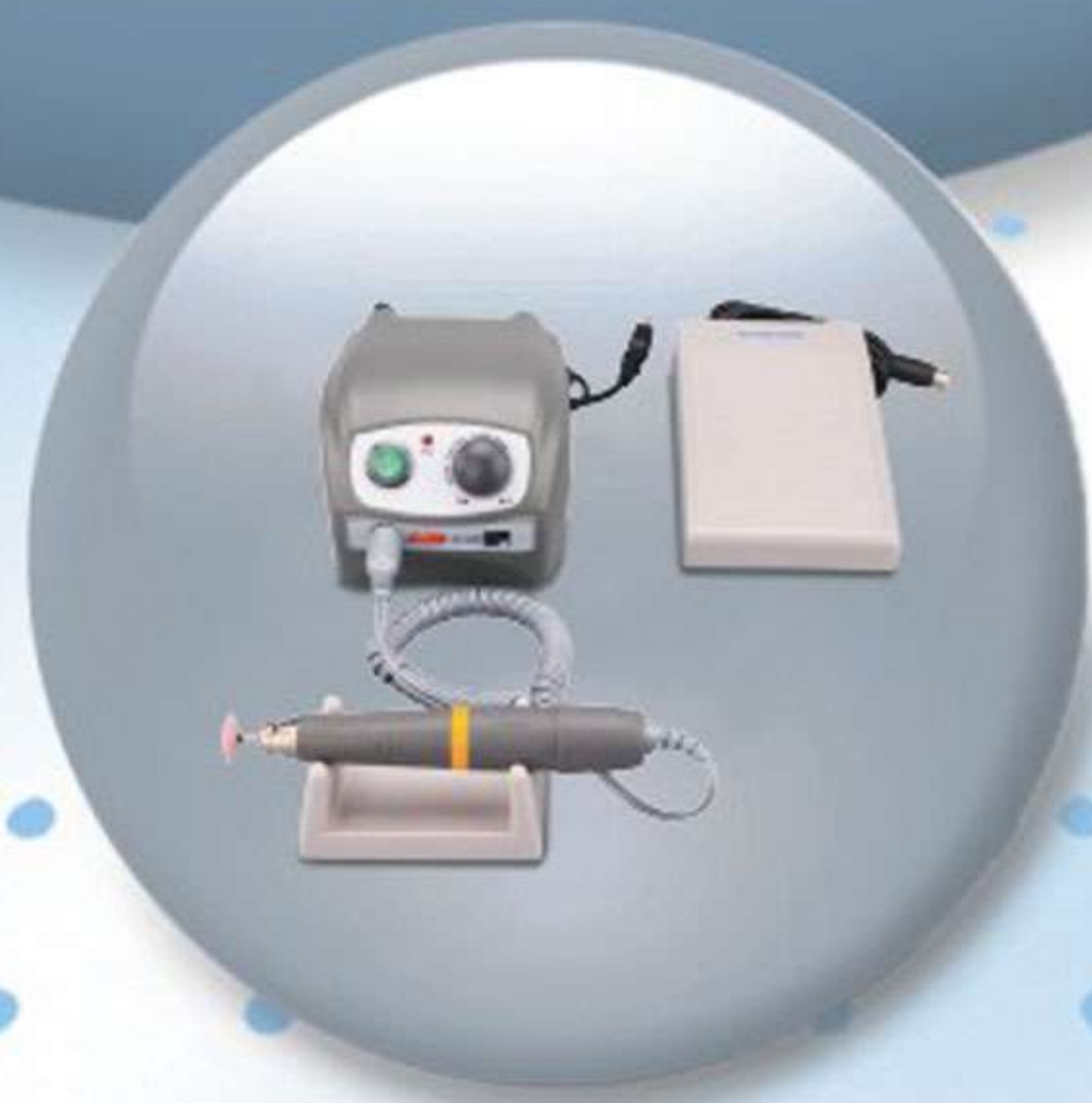

電動研磨機
Electric Rotary



氣動工具
Pneumatic Tool



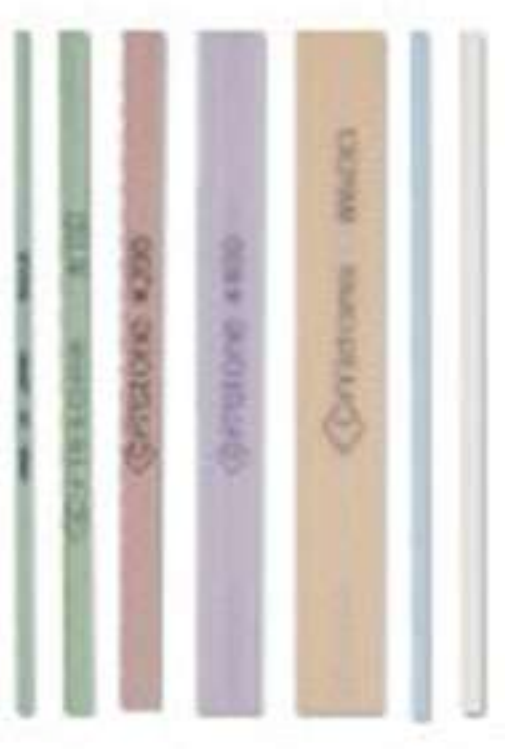

JR F02
水晶纖維油石
CRYSTAL FIBER STONES



DDC F17
圓錐修刀
CONED DIAMOND DRESSERS



F25
鎢鋼滾磨刀
SOLID CARBIDE



CS F03
犀利盾超級纖維油石
CERAMIC FIBER STONES



DDP F17
角錐修刀
PYRAMID DRESSERS



DPS F28
鑽石油石
DIAMOND POLISHING STONES



JR F05
迷你纖維油石
MINIATURE FIBER STONES



DDM F18
多石修刀
MULTI POINT DIAMOND DRESSERS



AB F29
刷
BRUSHES



JM S F06
迷你犀利盾纖維油石
MINI CERAMIC FIBER STONES



DDS F18
單石修刀
SINGLE DIAMOND DRESSERS



ABP F30
氧化鋁帶柄砂輪
ALUMINUM OXIDE GRINDING PINS



CDS F07
鑽石纖維油石
CERAMIC DIAMOND STONES



DDI F19
組合修刀
IMPREGNATED DIAMOND DRESSERS



DPC F31
鑽石砂布
DIAMOND FOIL
SP-FLO
德國超微粒光學拋光布
MICRO-POLIERLEINEN
(MADE IN GERMANY)



XH F08
油石夾柄
POLISHING STONE HOLDERS



DDH F19
手持式結合修刀
HAND DIAMOND DRESSERS



ABL F32
牛皮彈性帶柄砂輪
COWLEATHER ELASTIC GRINDING PINS



GS F09
油石(Made in Japan)
GS EDM STONES



BDS/BBS F20
鑽石磨棒
DIAMOND BURRS



ABR F32
海綿彈性帶柄砂輪
SPONGE ELASTIC GRINDING PINS



FLASH 600 F11
油石研磨液
(Made in Japan)
FLASH 600 STONING OIL



M F21
鑽石磨棒
DIAMOND BURRS



ABR-CM F33
日本制大和海綿輪
DAIWA RABIN(MADE IN JAPAN)



F12
鑽石銼刀系列
DIAMOND FILE SERIES



MM F23
鑽石及氮化硼(CBN)
DIAMOND & CBN MANDRELS



CMP/KMP F35
GS鑽石膏
GS DIAMOND COMPOUND

鑽石工具系列 Diamond File Series

JR

水晶纖維油石 Crystal Fiber Stones

Cristone[®] The Crystal Fiber Stones

Cristone水晶纖維油石以強韌的水晶陶瓷纖維所制成，強度比一般的纖維油石提高一倍，適合用於去除放電加工后(EDM)所產生的粗糙表面。高單位纖維含量以及整齊銳利的水晶纖維端面讓切削速度大幅度提升，使您的工作更有效率。

cristone stands for Crystal Stone made from using the highest quality, chemically produced crystal fibers. The crystalline structure of the crystal fibers Offers high polishing efficiency and incredible bending strength. These are the perfect stones for detail polishing. Extremely strong for tight ribs and slots, excellent for EDM removal.

高强度

High Strength

抗折强度1300MPa

The highest bending strength 1300MPa

高研磨力

High Polishing

研磨速度約提升2倍

(500mg 研磨速度縮短50%，#400使用實績)

2 times polishing efficiency of Ceramic stones!

(Can save 50% in EDM scale removal times)

平滑的切削面

High Surface

纖維構成面平整，研磨效果更佳！

(Ra=0.4 μ 研磨速度縮短50%，#400使用實績)

Optimal crystalline structure for polishing

(can save 50% cutting time to reach Ra=0.4 μ)

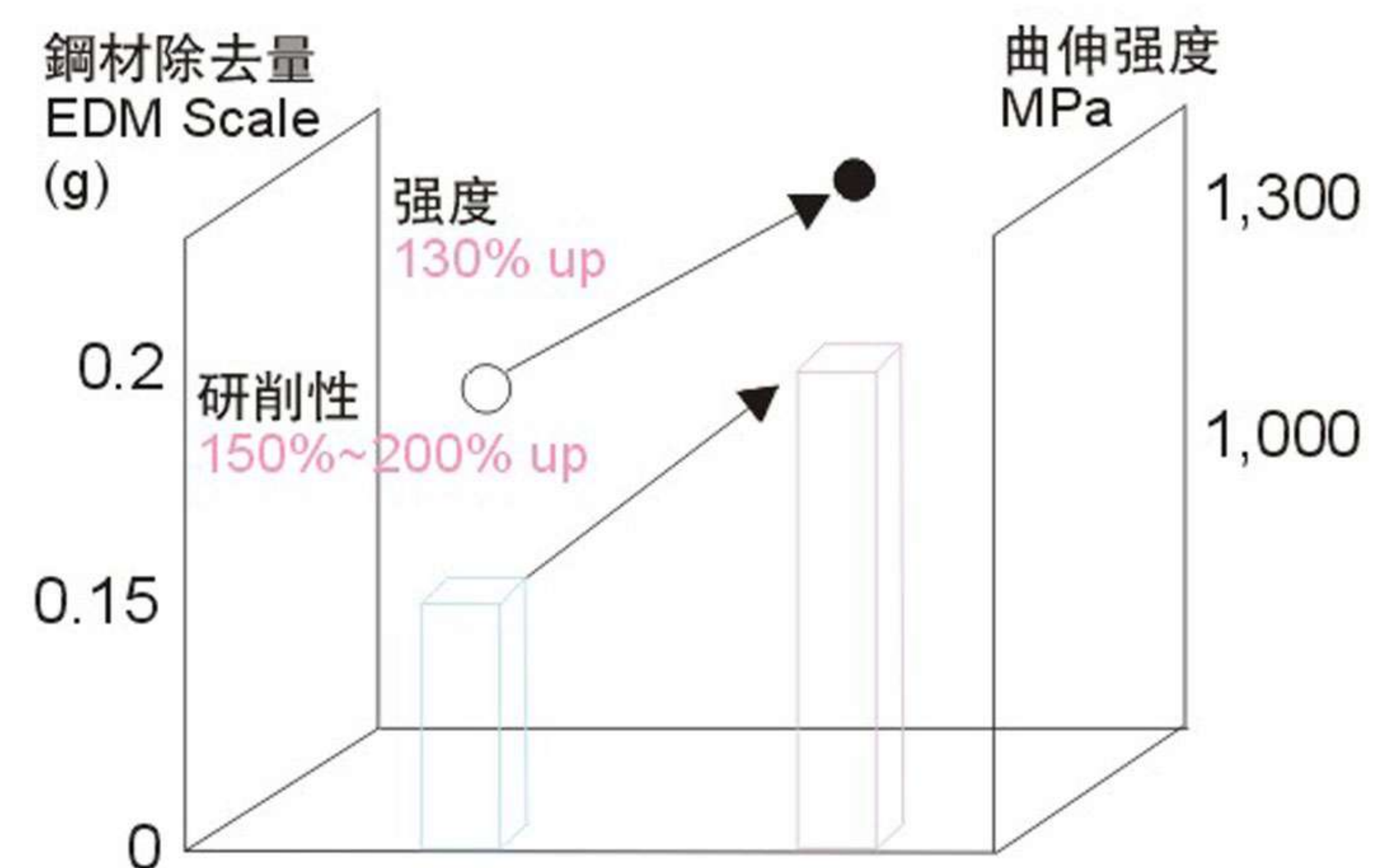
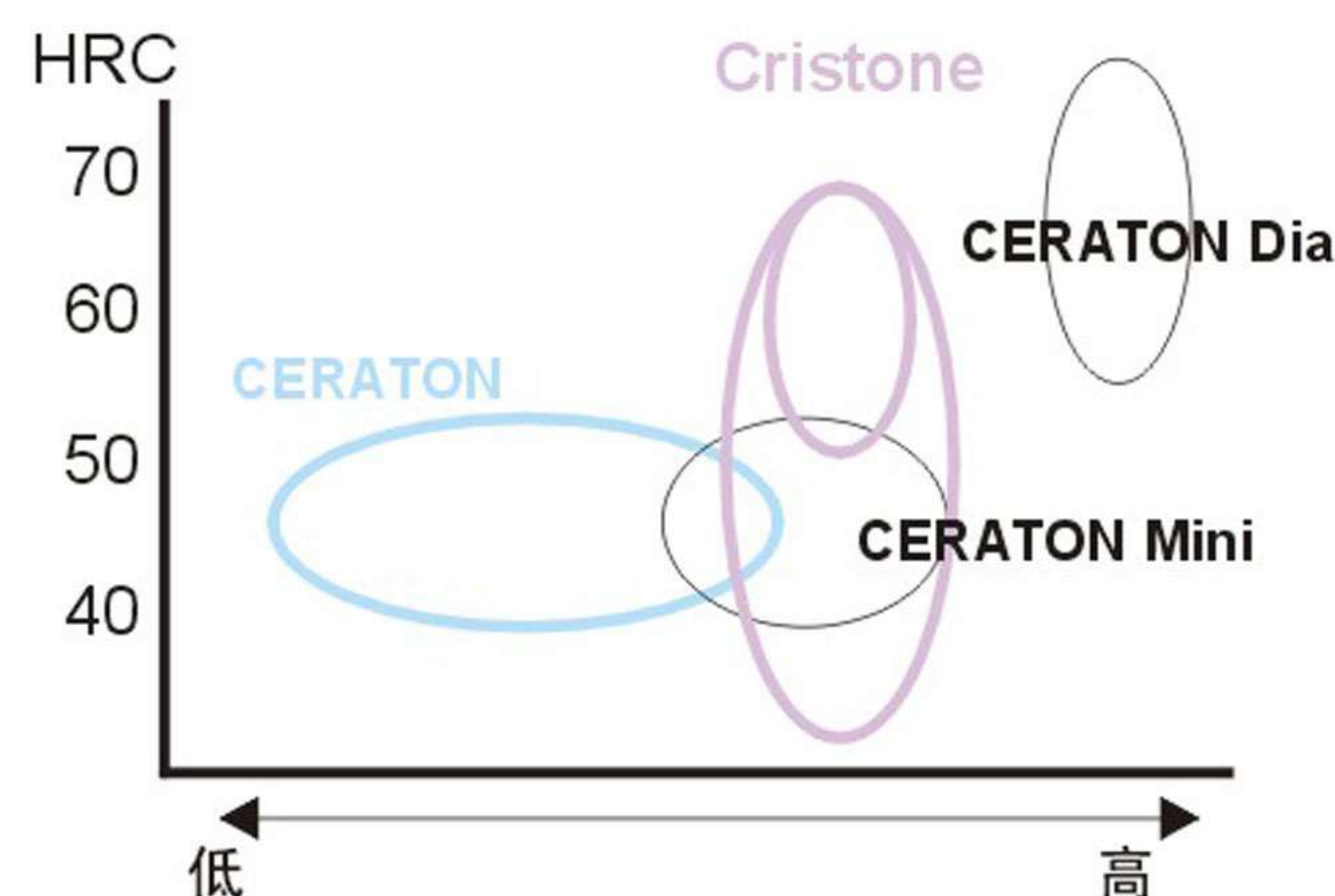

犀利盾系列纖維油石

水晶系列纖維油石

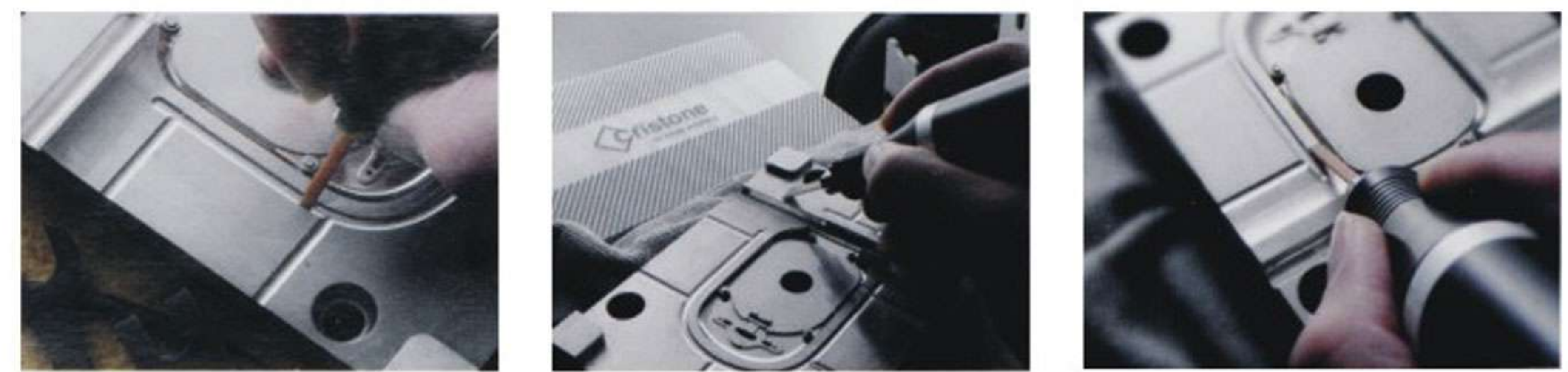

鑽石銼刀系列

粒度編號及訂購代號 Grit Size & Order No.

		#150	#200	#400	#600	#800	#1000
		Green	Pink	Violet	Orange	Blue	White
T W	1x2x100	JRG-0102100	JRP-0102100	JRV-0102100	JRO-0102100	JRB-0102100	JRW-0102100
T W	1x4x100	JRG-0104100	JRP-0104100	JRV-0104100	JRO-0104100	JRB-0104100	JRW-0104100
T W	1x6x100	JRG-0106100	JRP-0106100	JRV-0106100	JRO-0106100	JRB-0106100	JRW-0106100
T W	1x10x100	JRG-0110100	JRP-0110100	JRV-0110100	JRO-0110100	JRB-0110100	JRW-0110100
T W	1x13x100	JRG-0113100	JRP-0113100	JRV-0113100	JRO-0113100	JRB-0113100	JRW-0113100
D	∅3x100	JRG-03100	JRP-03100	JRV-03100	JRO-03100	JRB-03100	JRW-03100
D	∅2.35x100	JRG-0235100	JRP-0235100	JRV-0235100	JRO-0235100	JRB-0235100	JRW-0235100

鑽石工具系列 Diamond File Series

CS

犀利盾超級纖維油石 Ceramic Fiber Stones

CERATON® The Ceramic Fiber Stones

犀利盾纖維油石以陶瓷纖維結合強韌樹脂所制成，比起傳統油石更具高強度的切削力及切削壽命。手持研磨效果優于傳統油石且纖維油石本身耐高熱、富高彈性及不易塞穴的特性。適合使用于電動超音波研磨機、電動或氣動旋轉工具及氣動銼磨機等各類長時間連續加工機具。

CERATON is made from ceramic fibers bonded in thermosetting resin, exhibits superior strength compared by normal abrasive stones.

Long life and no clogging is suitable for all kinds of equipments like ultrasonic machines, high speed rotaries, Air Lappers & Air Grinders and also good by hand polishing.

鑽石銼刀系列

粒度	使用建議
Grit size	Application
#180 #250 #280	模具放電加工后之硬化表層去除及機械切削粗糙刀痕之去除 To remove the rough machining surface or hard EDM scale of tool and die steels.
#360 #400	細致加工痕迹之去除及一般拋磨 General lapping of finer surface scratch line of tool & die steels.
#700#1000 #1200	精細研磨或鏡面處理前之拋光 Fine polishing & finishing.
Ø3.00mm圓柱/Round	可搭配刻磨機當成研磨棒使用(長度勿超過50mm長), 亦或將之磨尖用于細致角落或窄縫處之研磨 It can used like grinding point(max, length 50mm), or by sharpening it for detail lapping

我們建議使油石端面和工件夾角呈現 $30^{\circ}\sim 40^{\circ}$ 的方式研磨以得到最佳的切削性

In order to reach the best performance, we recommend that the stone should be hold up-right making an angle of approx. $30^{\circ}\sim 40^{\circ}$ to the work piece.

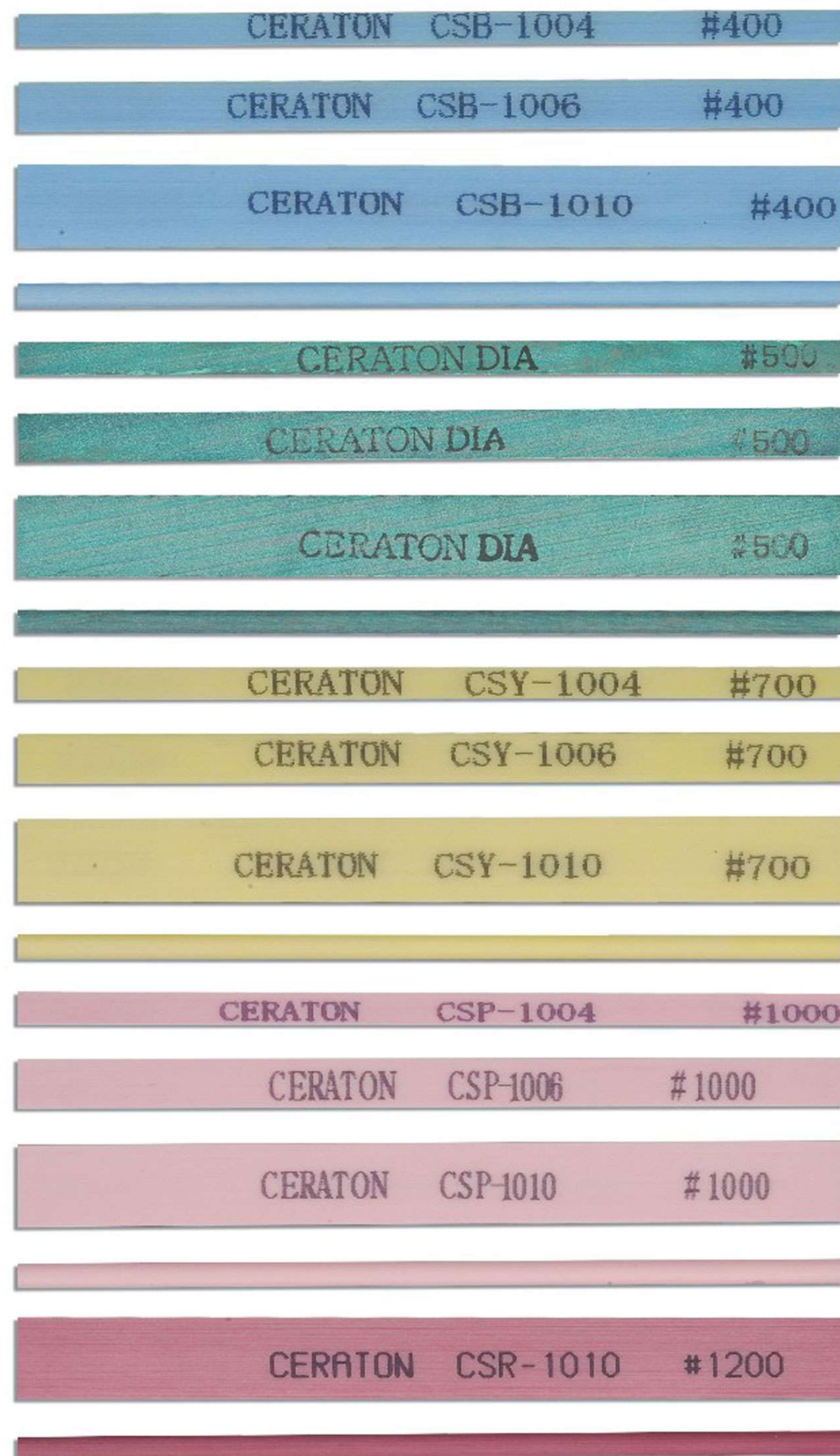
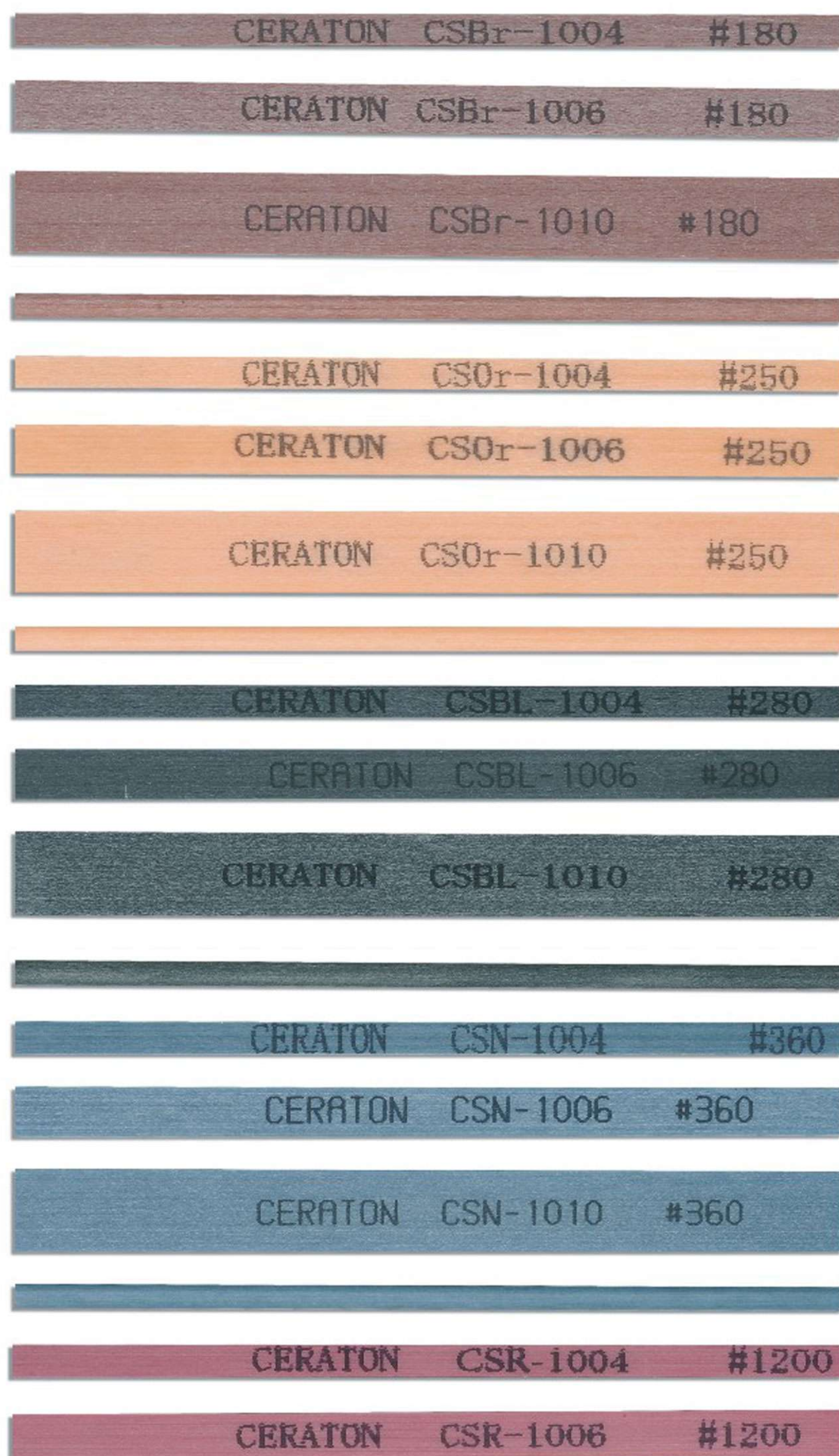

鑽石銼刀系列

粒度編號及訂購代號 Grit Size & Order No.

	#180	#250	#280	#360	#400	#500	#700	#1000	#1200
	Brown	Orange	Black	Navy Blue	Blue	Green	Yellow	Pink	Red
TxWxL (∅DxL)mm									
1x4x100	CSC-1004	CSO-1004	CSD-1004	CSN-1004	CSB-1004	CSG-1004	CSY-1004	CSP-1004	CSR-1004
1x6x100	CSC-1006	CSO-1006	CSD-1006	CSN-1006	CSB-1006	CSG-1006	CSY-1006	CSP-1006	CSR-1006
1x10x100	CSC-1010	CSO-1010	CSD-1010	CSN-1010	CSB-1010	CSG-1010	CSY-1010	CSP-1010	CSR-1010
∅2.35x100	CGC-235	CGO-235	CGD-235	CGN-235	CGB-235	CGG-235	CGY-235	CGP-235	CGR-235
∅3x100	CGC-30	CGO-30	CGD-30	CGN-30	CGB-30	CGG-30	CGY-30	CGP-30	CGR-30

鑽石工具系列 Diamond File Series

JR

迷你纖維油石 Miniature Fiber Stones

Cristone® The Mini Crystal Fiber Stones

水晶迷你纖維油石及犀利盾迷你纖維油石裁切成0.3x0.3mm~1x2mm等各式微小尺寸，主要用于凹縫、小溝槽等細部研磨，一般傳統油石或紅寶石油石如果裁成相同大小的尺寸時會產生容易斷裂的情形，但水晶迷你纖維油石及犀利盾迷你纖維油石具高強度的韌性是用于解決細部加工首選的研磨工具。

Mini Crystal Fiber Stone are cut by crystal fiber stone and Mini Ceramic Fiber Stone are cut by ceramic fiber stone.

Each size from 0.3x0.3mm~1x2mm. Ideal for various mold and dies detail lapping.

Traditional oil stone and ruby stones in such a small sizes are very easy to break, while mini ceramic stone provide high strength and high elasticity. Due to its hard to break, they resolve the problem of using these stones.

用途

適合于各類模具一般研磨或精加工使用尤其針對細部雕刻、溝縫、R角等複雜表面等的研磨。此外對於小型零件的細部研磨，水晶迷你纖維油石及犀利盾迷你纖維油石是您完美的選擇。

It is good for all type of molds and dies fine and super fine finishing. Especially for engraving parts, slight ribs, R ribs, corners, complicated area and details.

Besides, all other tool parts that needs details lapping. Our Mini crystal fiber stone and Mini ceramic fiber stone will be the wonderful tools.

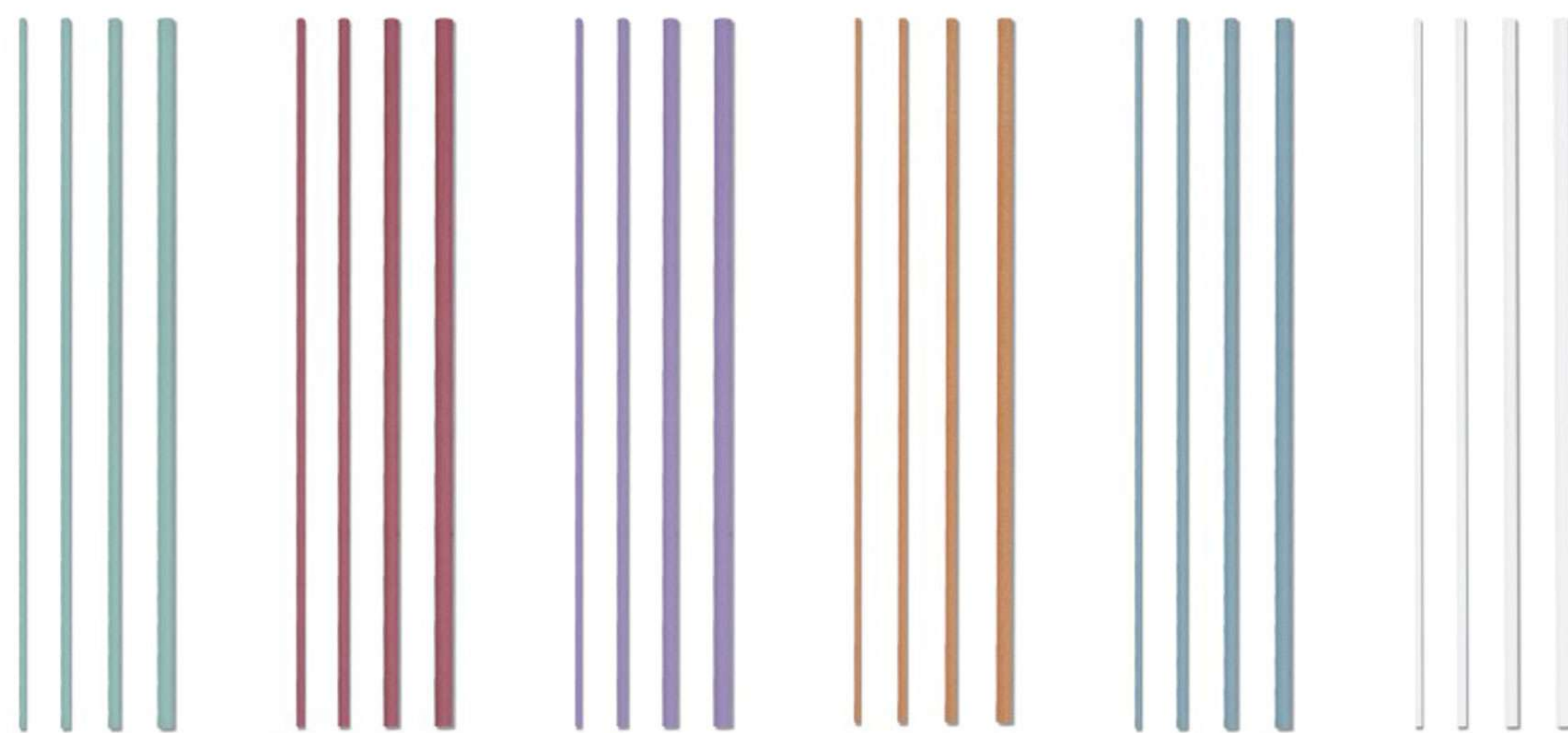

粒度編號及訂購代號 Grit Size & Order No.

	#150	#200	#400	#600	#800	#1000	
	Green	Pink	Violet	Orange	Blue	White	Holder
TxWxL (∅DxL)mm							
0.3x0.3x100	JR150-0303100	JR200-0303100	JR400-0303100	JR600-0303100	JR800-0303100	JR1000-0303100	XH-005
0.5x0.5x100	JR150-0505100	JR200-0505100	JR400-0505100	JR600-0505100	JR800-0505100	JR1000-0505100	XH-007
0.7x0.7x100	JR150-0707100	JR200-0707100	JR400-0707100	JR600-0707100	JR800-0707100	JR1000-0707100	XH-009
0.9x0.9x100	JR150-0909100	JR200-0909100	JR400-0909100	JR600-0909100	JR800-0909100	JR1000-0909100	XH-013

單一尺寸，粒度最小訂購量10支/盒 Minimum order 10pcs/box per grit size.

迷你纖維油石是將纖維油石切成細微尺寸，從0.3x0.3mm到1x2mm。專門使用于各種模具之細微部位或是其它類似之加工，由于陶瓷纖維具有高抗折強度，可解決一般油石易斷之困擾。

迷你纖維油石可適用於各種模具之研磨及各種零件之精細拋光，尤其是雕刻部位之加工、微小肋部、模具角部精細拋磨及各種細微或複雜部位之加工。

Applications

It is excellent stone for EDM removal and is suitable for use on all type of molds and dies, fine and super fine finishing. Especially for engraving parts, slight ribs, radius ribs, corners, complicated area and details.

Besides, all other tool parts that need details lapping, Our Mini Ceramic Fiber Stone will be the wonderful tools.

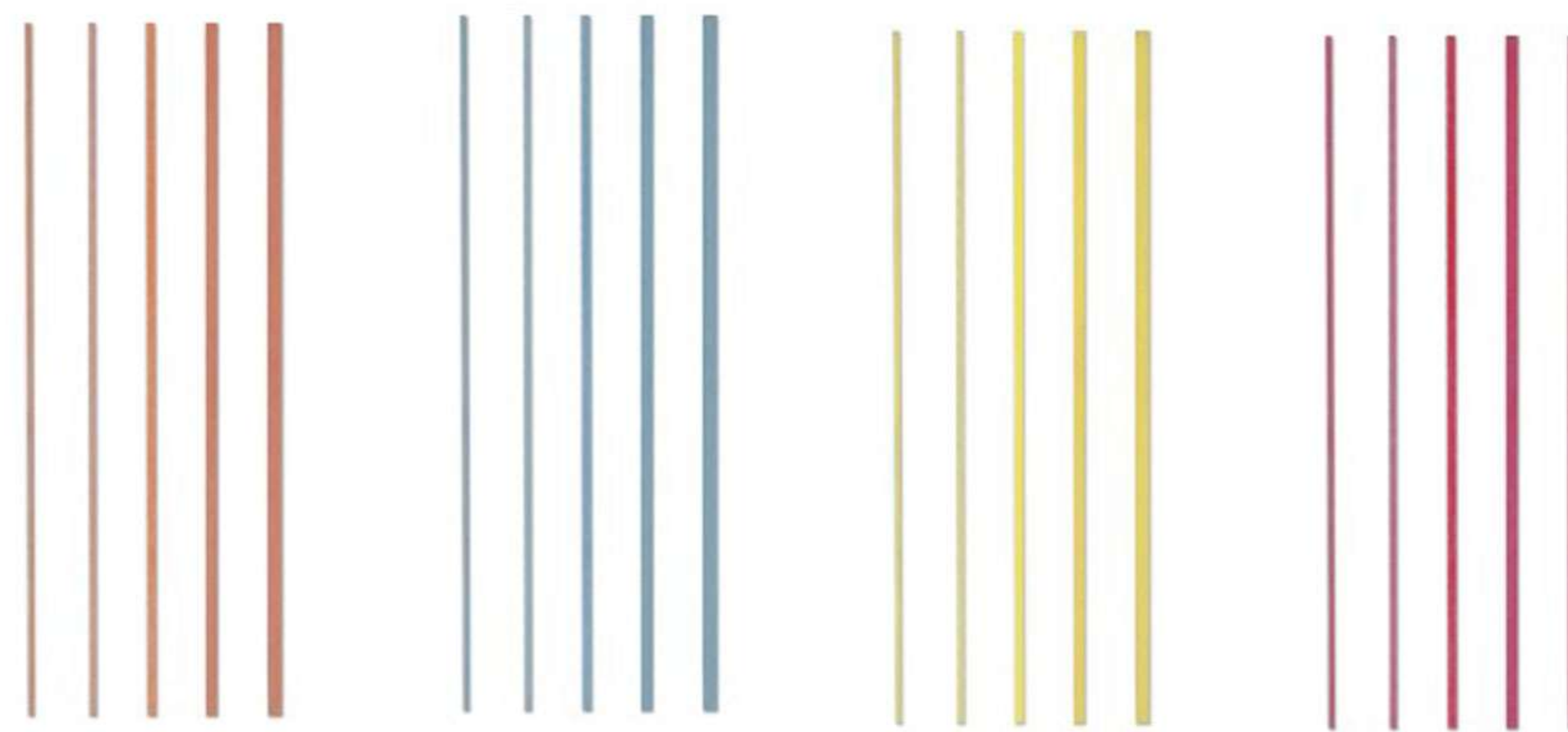

CERATON[®] The Mini Ceramic Fiber Stones

粒度編號及訂購代號 Grit Size & Order No.

	#250	#400	#700	#1200	Holder
	Orange	Blue	Yellow	Red	油石夾柄
TxWxL (∅DxL)mm					
0.3x0.3x50	JMOS-035	JMBS-035	JMYS-035	JMRS-035	XH-005
0.5x0.5x50	JMOS-055	JMBS-055	JMYS-055	JMRS-055	XH-007
0.7x0.7x50	JMOS-075	JMBS-075	JMYS-075	JMRS-075	XH-009
0.9x0.9x50	JMOS-095	JMBS-095	JMYS-095	JMRS-095	XH-013
1.0x2.0x100	JMOS-121	JMBS-121	JMYS-121	JMRS-121	XH-200
∅0.9x50	JMOG-105	JMBG-105	JMYG-105	JMRG-105	XH-009
∅2.0x100	JMOG-201	JMBG-201	JMYG-201	JMRG-201	XH-200

鑽石工具系列 Diamond File Series

CDS

鑽石纖維油石 Ceramic Diamond Stones

- 1** 一般的纖維油石的切削性来自于油石的端面，但鑽石纖維油石的各部位像是平面、側邊或先端等皆可以使用。
The ordinary ceramic fiber stone is efficient only to lap its end side or edge, while the ceramic diamond stone works well with any sides.
- 2** 一般傳統油石無法加工如超硬度模具等特殊材質的模具，但鑽石纖維油石無此限制。
Materials those are difficult to be ground by ordinary ceramic stone, now the ceramic diamond stone can provide a much better cut.
- 3** 鑽石纖維油石可用于各類的加工如：EDM放電后的表面研磨、鎢鋼模具的拋光、陶瓷加工研磨以及玻璃表面的研磨等。
Ceramic diamond stone is idea for lapping all kind of harden steels, EDM surface, tungsten carbide, ceramics and glasses efficiently.

CERATON® The Ceramic Diamond Fiber Stones

以獨家技術結合陶瓷纖維及鑽石研磨顆粒再搭配強韌的樹脂所制成此款鑽石纖維油石。加入鑽石研磨粉后除了大幅的提升纖維油石的切削性外，對於硬度較高的工件更是游刃有余并同時縮短了加工的時程。

Ceramic diamond stones are made of diamond abrasives and ceramic fibers bonded together with thermosetting resin. The combination of diamond and ceramic fibers creates the outstanding cutting performance. Ceramic diamond stone is a perfect lapping tool.



粒度編號及訂購代號 Grit Size & Order No.

	#200	#400	#600	#800
	Black	Gray	Moss Green	Green
TxWxL (∅DxL)mm	●	●	●	●
1x4x100	CDS1004-200	CDS1004-400	CDS1004-600	CDS1004-800
1x6x100	CDS1006-200	CDS1006-400	CDS1006-600	CDS1006-800
1x10x100	CDS1010-200	CDS1010-400	CDS1010-600	CDS1010-800
∅3x100	CDS30-200	CDS30-400	CDS30-600	CDS30-800

對於特殊含鐵元素材質的工件，我們另外可提供CBN磨料的纖維油石。詳細內容請洽詢本公司。

In some special applications, ceramic CBN stones are also available.

Depend on your request. Other size and grits are also available, Please ask our salespersons for details.

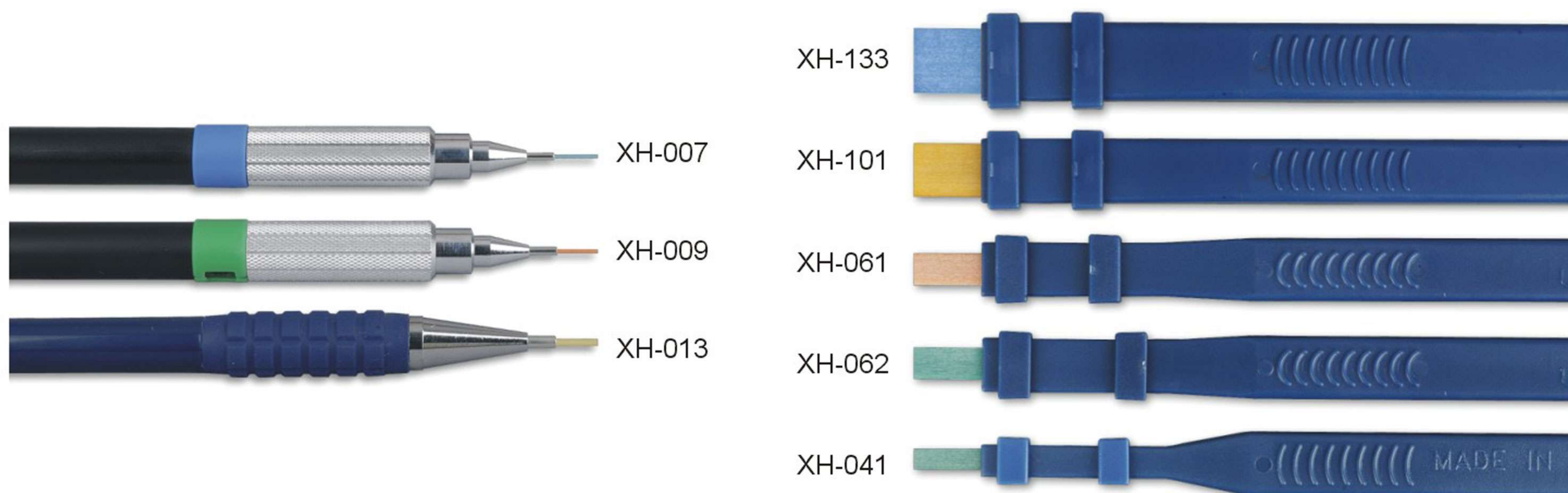

編號	可夾持尺寸		運用
Order No .	Holding Capacity		Applications
XH-041	平形/FLAT	4x1	纖維油石 For Fiber Stone
XH-061	平形/FLAT	6x1	纖維油石 For Fiber Stone
XH-101	平形/FLAT	10x1	纖維油石 For Fiber Stone
XH-22	圓/ROUND	圓 \varnothing 3.0 Round \varnothing 3.0	纖維油石 For Fiber Stone

編號	可夾持尺寸		運用
Order No .	Holding Capacity		Applications
XH-062	平形/FLAT	6x2~6x3	一般油石 For Oil Stone
XH-133	平形/FLAT	13x3	一般油石 For Oil Stone
XH-136	平形/FLAT	13x6.3	一般油石 For Oil Stone

編號	可夾持尺寸		運用
Order No .	Holding Capacity		Applications
XH-005	方形 SQUARE	0.3x0.3或圓 \varnothing 0.5 0.3x0.3 or Round \varnothing 0.5	迷你纖維油石 For Mini Fiber Stone
XH-007	方形 SQUARE	0.5x0.5或圓 \varnothing 0.7 0.5x0.5 or Round \varnothing 0.7	迷你纖維油石 For Mini Fiber Stone
XH-009	方形 SQUARE	0.7x0.7或圓 \varnothing 0.9 0.7x0.7 or Round \varnothing 0.9	迷你纖維油石 For Mini Fiber Stone
XH-200	平形 FLAT	2x1或圓 \varnothing 2.0 2x1 or Round \varnothing 2.0	迷你纖維油石 For Mini Fiber Stone
XH-013	方形 SQUARE	0.9x0.9或圓 \varnothing 1.3 0.9x0.9 or Round \varnothing 1.3	迷你纖維油石 For Mini Fiber Stone

鑽石工具系列 Diamond File Series

GS

油石 (Made in Japan) GS EDM Stones

BLK (BLACK STONE)



#120 #180 #240 #320 #400 #600
#800 #1000 #1200 #1500 #2000
#3000

品名	砥粒	硬度	結合劑	尺寸	用途
Grain	Hardness	Bond	Size	Application	
BLK	C	中軟 (Medium Soft)	V	3x6x100 3x13x150 3x6x150 5x13x150	一般模具 硬質材料模具等 General mold for hard material mold

細緻，鋒利的研磨端，能迅速將模具細部完整加工。中軟硬度的Sic砥粒，不但可用于鑽石之成型，更適用於高標準要求的模具鏡面細部的修飾。同時也適用於硬質材料模具的研磨。This stone is made of medium soft SIC grains with sharp points designed to swiftly fit to detail forms of mold. It is best suitable to operations before diamond paste processing and best for mold which needs fine finishing, such as mirror finishing. Also suitable for polishing hard material mold.

GC (GC STONE)



#120 #180 #240 #320 #400 #600
#800 #1000 #1200 #1500 #2000
#3000

品名	砥粒	硬度	結合劑	尺寸	用途
Grain	Hardness	Bond	Size	Application	
GC	GC	中硬 (Medium Hard)	V	3x6x100 3x13x150 3x6x150 5x13x150 3x13x100	一般模具及非鐵金屬， 硬質工具等 For nonferrous metals and hard material tools

綠色SIC砥粒加上特殊結合劑的超完美結合所制作出專門針對細部修飾，拋光的GC STONE，除了可以安穩的處理表層細微的紋路，更可用在超硬熱處理的鋼材修飾上。With green SIC grains mixed among special bond. This stone does not damage surface and give stable finishing. It is suitable for carbide and quenched steels.

EDM-BL (EDM STONE)



#120 #180 #240 #320 #400
#600 #800 #1000 #1200

品名	砥粒	硬度	結合劑	尺寸	用途
Grain	Hardness	Bond	Size	Application	
EDM	WA	硬 (Hard)	V	1x10x100 3x13x150 3x6x100 5x13x150 3x6x150 6x6x150	一般模具 及放電加工 后的表面研磨 Surface polish after EDM processing for general mold

可輕易去除EDM后表面頑固的吸附粒子，却又不傷及模具表層。銳角部份及角落的細部研磨有著非常顯著性能的發揮。

This special stone has higher hardness and less abrasion. It shows high performance for detailed polish, such as corners of acute angles.

訂購範例 Order Ex PS 型號 Model No. BLK 產品代號 Item 36100 尺寸 Size 120 粒度 Grit

**DIE
(DIE STONE)**

#120 #180 #220
#320 #400 #600

品名	砥粒	硬度	結合劑	尺寸	用途
	Grain	Hardness	Bond	Size	Application

DIE	A	中軟 (MediumSoft)	V	3x6x150 5x13x150 3x13x150 6x6x150	淬鋼合金之表面研磨 Surface polishing for quenched steel
-----	---	--------------------	---	--------------------------------------	--

在硬度範圍HRC47-63的鋼材表面研磨上會有優秀并最適合的表現。超銳利的A級砥粒亦可用于切割，更適合硬質材料的研磨。
A best stone for quenched steel of HRC 47 to 63. Medium soft hardness of this stone give steel an excellent finishing and the sharp cutting of A grains enables polishing for hardened materials.

**EDM-BR
(LAP MATE EDM STONE)**

#120 #180 #240 #320 #400
#600 #800 #1000 #1200

品名	砥粒	硬度	結合劑	尺寸	用途
	Grain	Hardness	Bond	Size	Application

EDM-BR	WA	中硬 (Medium Hard)	V	1x10x100 5x13x150 3x6x100 6x6x150 3x6x150 10x13x150 3x13x150	一般模具及放電加工 后的表面研磨 Surface lapping after EDM processing for general mold
--------	----	---------------------	---	---	---

密度高且耐磨的WA砥粒，在研磨過程中，可抑制最小量的粒子脫落。加上使用特殊的樹脂加工，可讓油石本身，尤其是研磨的先端常保如新。適用於細部的研磨或中度的修飾。
The Lap Mate is manufactured for keeping new blade constantly with minimum bonds and maximum density of grains to prevent from falling out. Due to our special processed resin, the form of the edge lasts long and can be used for detail finishing as well as rough and medium finishing.

單一尺寸，粒度最小訂購量

1x10x100	20pcs/box	3x13x100	10pcs/box
3x3x150		3x13x150	
3x6x100		5x13x150	
3x6x150		6x6x150	
4x4x150		6x13x150	

鑽石工具系列 Diamond File Series

GS

油石 (Made in Japan) GS EDM Stones

SO
(SUPER ORANGE STONE)



#120 #180 #220
#320 #400 #600

VH (Made in USA)
(GOLDEN STONE)



#150 #180 #240 #400 #600
#1200 #1500 #2500

品名	砥粒	硬度	結合劑	尺寸	用途
	Grain	Hardness	Bond	Size	Application

SO	WA	中硬 (Medium Hard)	V	3x6x150 3x13x150 5x13x150	6x6x150 6x13x150	搭配使用往覆式氣動研磨機， 超音波研磨機效果更佳 Surface lapping after EDM processig for gneral. Use with stroke air profiler-linear
----	----	---------------------	---	---------------------------------	---------------------	--

特別設計用于往覆式氣動工具及超音波研磨機，特殊橘色WA砥粒除了不易折斷的特性，更可維持研磨先端的鋒利，最適合用在EDM后硬化層附著物的去除。

Best stone for removing hardned layer after EDM processing. You can use this stone with stroke air profiler-linear machine and ultrasonic machine because this stone is very hard break. You can always keep new and sharp blade by avoiding grains to drop out with using original special bond. This original new bound makes it possible to remove hardened layer EDM processing.

品名	砥粒	硬度	結合劑	尺寸	用途
	Grain	Hardness	Bond	Size	Application

VH	VH	中硬 (Medium Hard)	V	3x3x150 4x4x150 3x6x150	3x13x150 6x6x150 6x13x150	放電加工后的表面和銑刀加工 痕迹更具有優异的去除性。 Delivering exceptional performance on EDM surfaces, milling and machining marks.
----	----	---------------------	---	-------------------------------	---------------------------------	---

從選擇優質氧化鋁顆粒和專有的處理過程中，VH油石是中等硬度，具有快速去除工件表面紋路及保持油石低磨耗不變形，并留下了如絲般柔滑質感。VH油石并不需要漫長加工的過程也不需使用潤滑油，是款高效能的EDM油石。

Made from select premium aluminum oxide grain and a proprietary treatment process, the VH stone is of medium hardness with a fast breakdown offering quick material removal while contouring quickly and leaving a silky smooth finish. The VH stone does not require a lengthy pre-lubrication process and is terrific when used during hand stoning as well as with profilers.

FLASH 600 油石研磨液 (Made in Japan) Flash 600 Stoning Oil

日本3A獨家研發傳統油石研磨液
FLASH 600 is originally developed by 3A-Sangyo

傳統油石加工時使用油石研磨液是非常重要的，因為它能有效的提升傳統油石的切削性及延長油石的壽命。

The role of the stoning oil is significantly important for the stick type Abrasive stone.

- 1** 減低油石磨耗及降低摩擦時所產生的溫度使油石的壽命更長。
Strengthen the polishing power of the grains, reduce the abrasion of grains, cool down the friction heat and give the stones long life.
- 2** 防止粉塵堵塞于油石氣孔中，使加工時的磨屑順利的排除不阻塞提升油石的切削性另可以防止模具損傷。
Protect work pieces from scratches by washing away polished wastes and felled down grains, keep new edge constantly and prevent the holes from clogging and crushing.
- 3** 有效的提升傳統油石的切削性及延長油石的壽命。
Maximize the sharpness and give the longest life for whetstones.
- 4** 配方温和不傷肌膚。
FLASH 600 is gentle for human skin of the hands and legs.

※部分油石及模具不需要使用研磨液，詳細內容可向本公司洽詢。
There are some stones and some cases which don,t need stoning oil. Ask our salespersons on details.



容量：500 c.c
另有30 c.c.小瓶裝可供選擇
30 c.c. is also available

訂購代號 FLASH600-500(500 c.c)
Order No. FLASH600-030(30 c.c)

TDF130 平斜鑽石銼刀 Tapered Diamond File

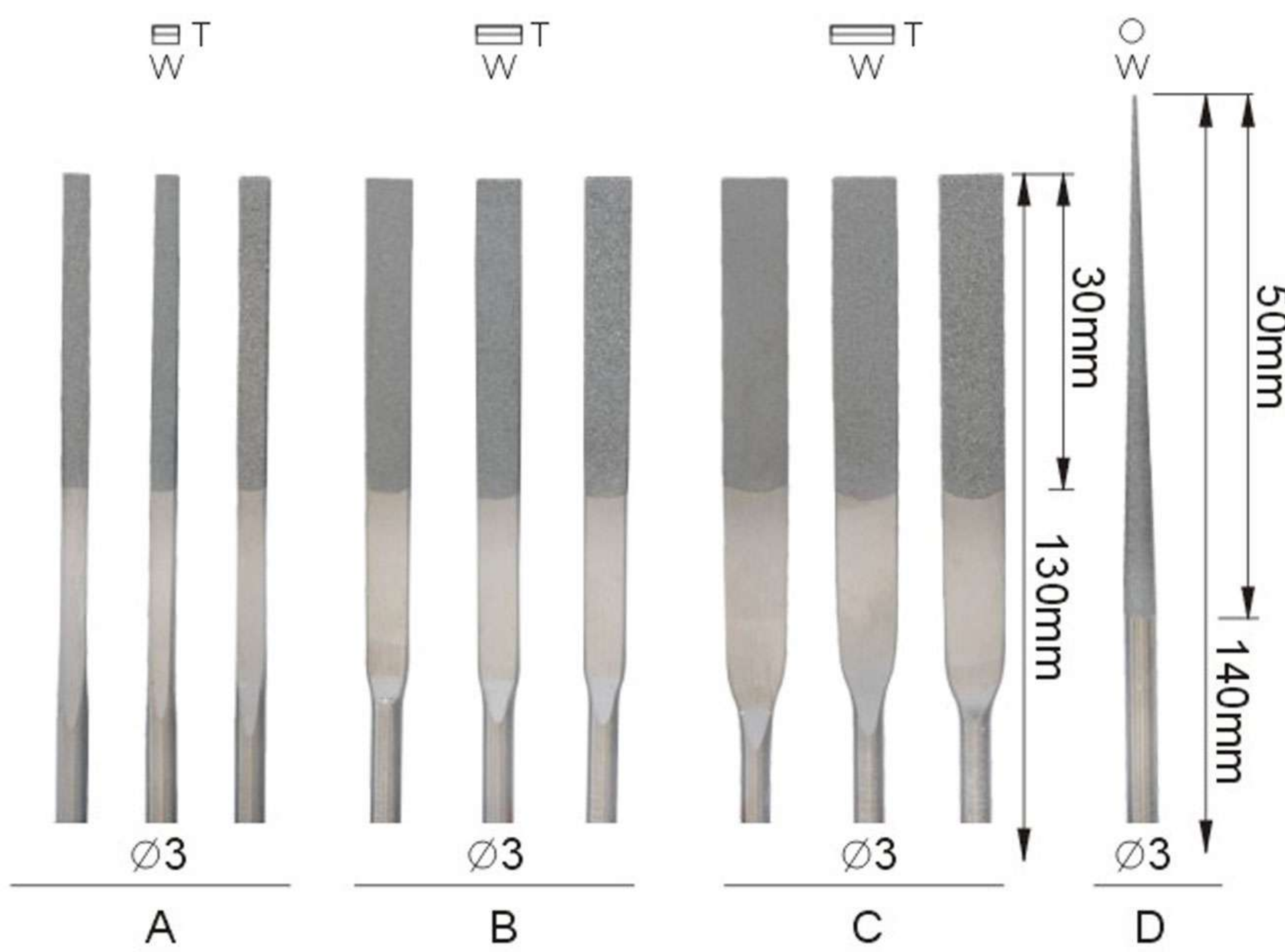

訂購編號 Order No.	形狀 Shape	全長 L	鑽石長度 B	寬度 W	厚度 T	柄徑 Shank	粒度 Grit		
TDF-130A-200	A	130	30	2	0.4~1.7	Ø3	#200		
TDF-130A-400							#400		
TDF-130A-600							#600		
TDF-130B-200	B			4			6	#200	
TDF-130B-400									#400
TDF-130B-600									#600
TDF-130C-200	C			6			#400		
TDF-130C-400									#400
TDF-130C-600									#600
TDF-130D-400	D	140	50	3					#400
TDF-130S		10支組套裝/10 Pieces/Set(以上型號各1支)							

TDF170 平斜鑽石銼刀 Tapered Diamond File

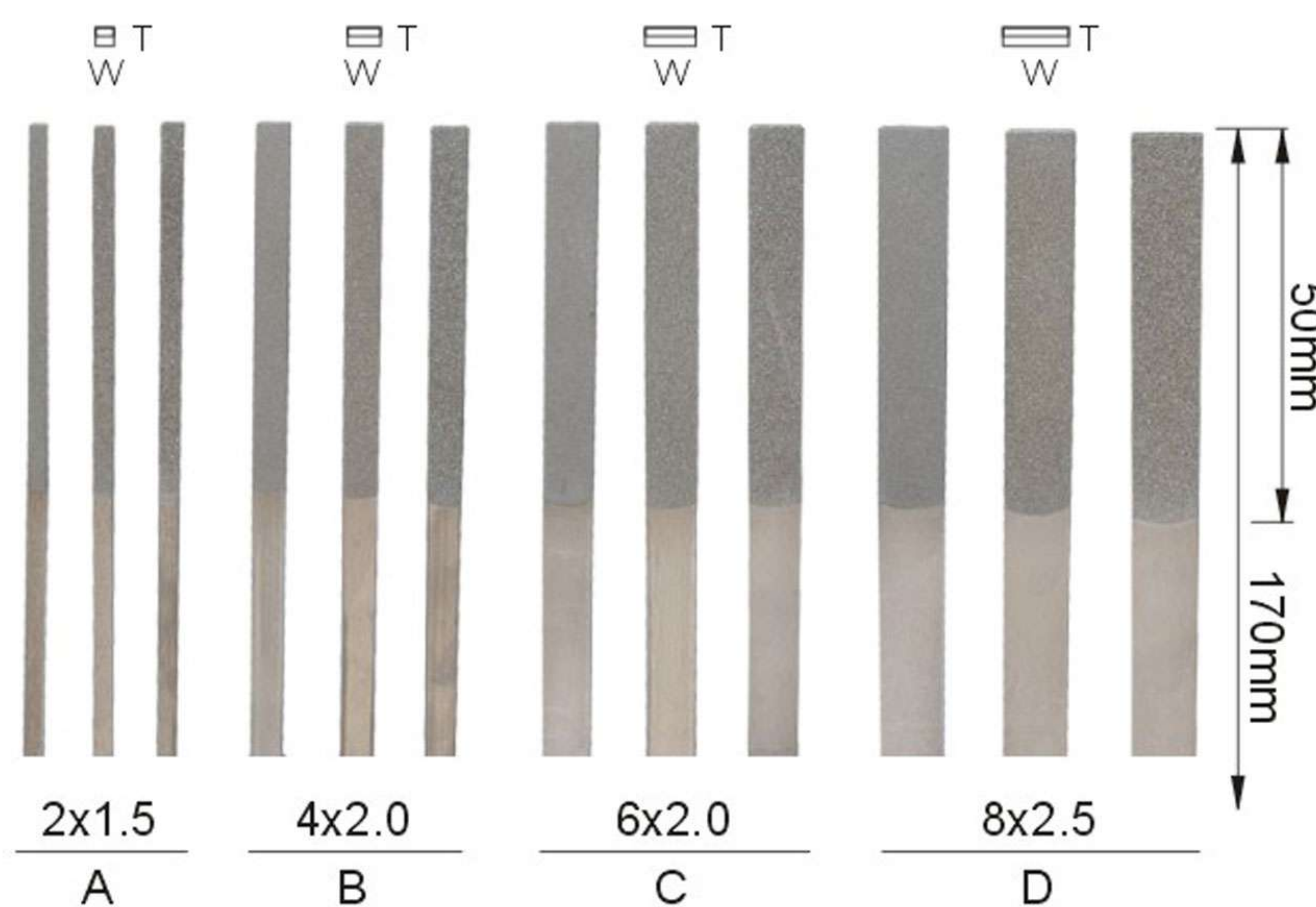

訂購編號 Order No.	形狀 Shape	全長 L	鑽石長度 B	寬度 W	厚度 T	柄徑 Shank	粒度 Grit			
TDF-170A-120	A	170	50	2	0.4~1.5	2x1.5	#120			
TDF-170A-200							#200			
TDF-170A-400							#400			
* TDF-170A-600				#600						
TDF-170B-120	B			4		0.5~20	4x2.0	#120		
TDF-170B-200									#200	
TDF-170B-400									#400	
* TDF-170B-600				#600						
TDF-170C-120	C			6		0.5~2.0	6x2.0		#200	
TDF-170C-200										#200
TDF-170C-400										#400
* TDF-170C-600				#600						
TDF-170D-120	D	8	0.5~2.5	8x2.5	#120					
TDF-170D-200						#200				
TDF-170D-400						#400				
* TDF-170D-600		#600								
TDF-170S		12支組套裝/12 Pieces/Set								

帶“*”號之規格為選購品。

FDF140 平型鑽石銼刀 Flat Diamond File

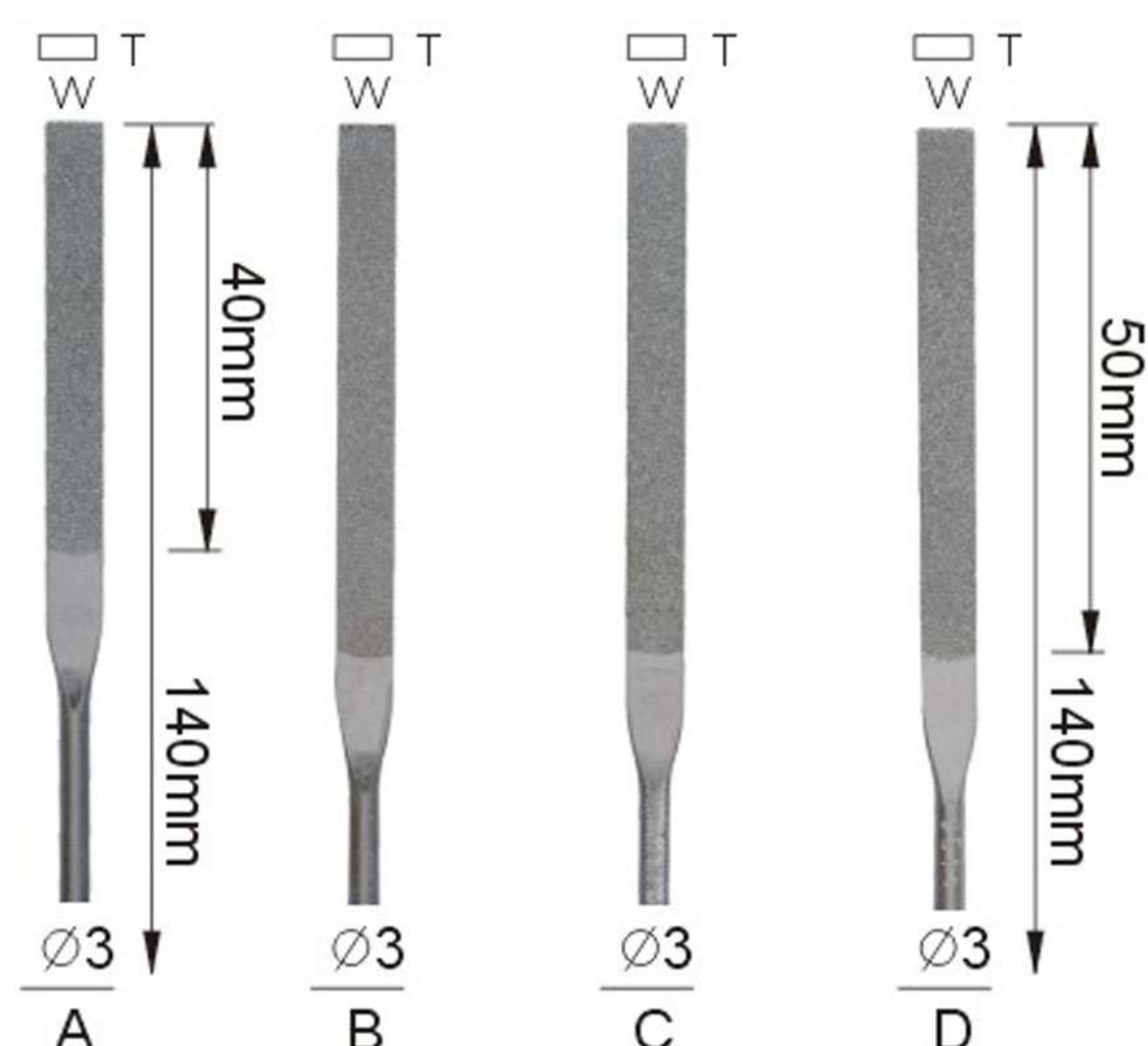

訂購編號 Order No.	形狀 Shape	全長 L	鑽石長度 B	寬度 W	厚度 T	柄徑 Shank	粒度 Grit
FDF-140A-粒度(Grit)	A	140	40	5.5	0.5	Ø3	#120
FDF-140B-粒度(Grit)	B		50		0.8		
FDF-140C-粒度(Grit)	C		50		1.0		
FDF-140D-粒度(Grit)	D		50		1.2		
FDF-140S-粒度(Grit)		4支組套裝/4 Pieces/Set(以上型號同粒度各1支)					

鑽石銼刀系列 Diamond File Series

NDF140 精密型鑽石銼刀 Needle Diamond File

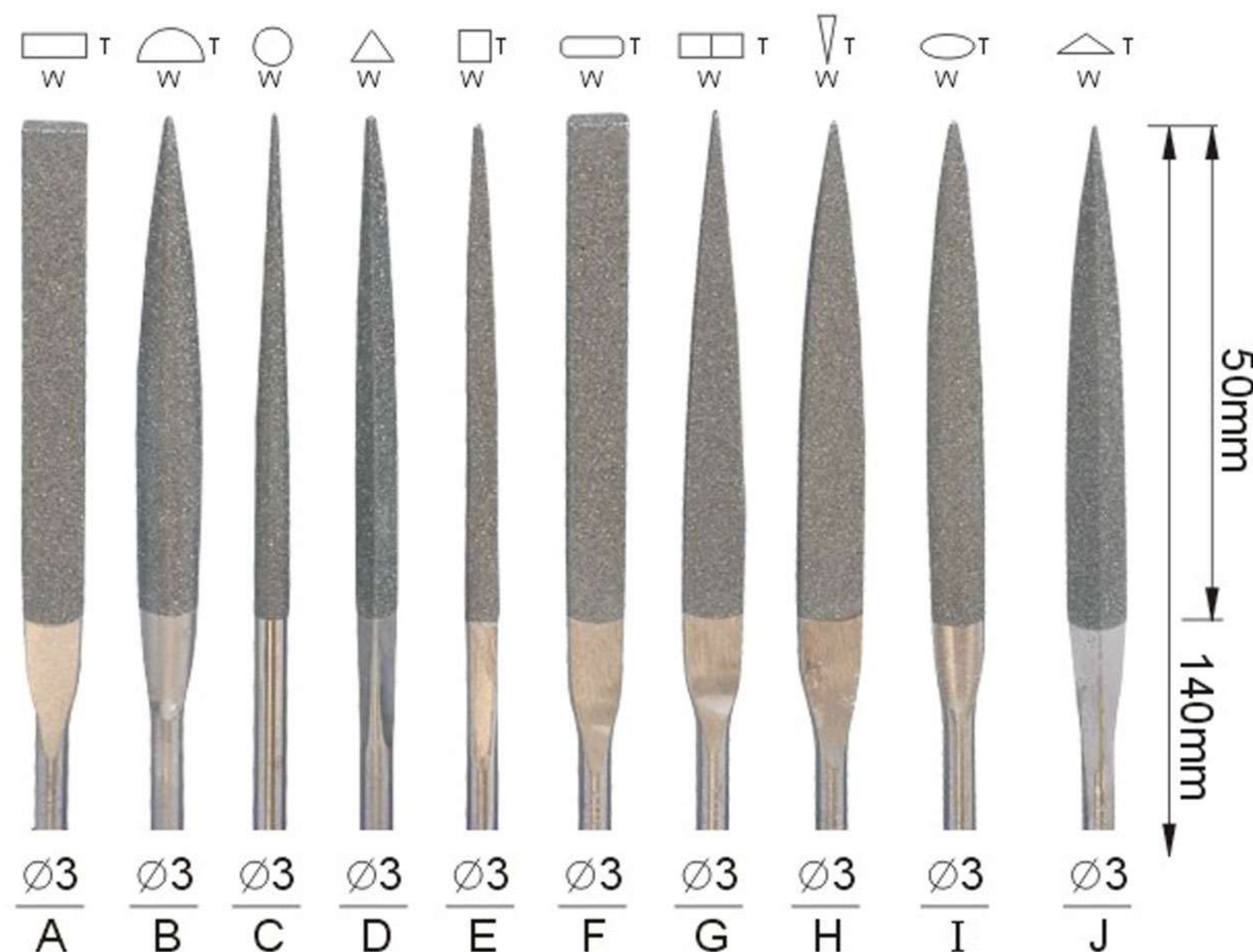

訂購編號 Order No.	形狀 Shape	全長 L	鑽石長度 B	寬度 W	厚度 T	柄徑 Shank	粒度 Grit
NDF-140A-粒度(Grit)	A	140	50	5.5	1.6	Ø3	#120 #200 #400
NDF-140B-粒度(Grit)	B			5	2		
NDF-140C-粒度(Grit)	C			3	3		
NDF-140D-粒度(Grit)	D			3.5	3.5		
NDF-140E-粒度(Grit)	E			2.5	2.5		
NDF-140F-粒度(Grit)	F			5.2	1.6		
NDF-140G-粒度(Grit)	G			5.5	1.3		
NDF-140H-粒度(Grit)	H			6	1.5		
NDF-140I-粒度(Grit)	I			5	2		
NDF-140J-粒度(Grit)	J			5	2.2		
NDF-140S-粒度(Grit)	10支組套裝/10 Pieces/Set(以上型號同粒度各1支)						

NDF180 精密型鑽石銼刀 Needle Diamond File

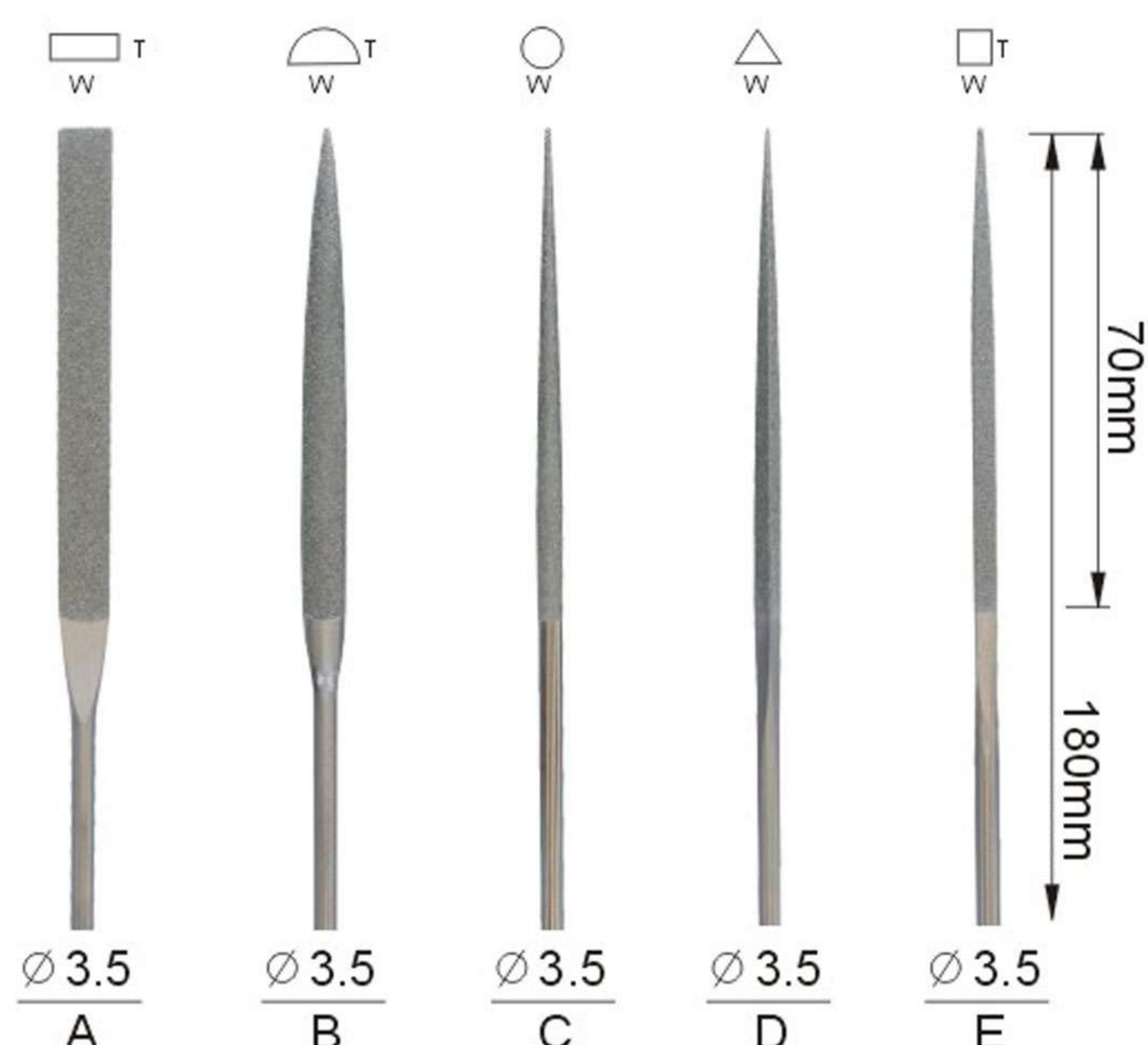

訂購編號 Order No.	形狀 Shape	全長 L	鑽石長度 B	寬度 W	厚度 T	柄徑 Shank	粒度 Grit
NDF-180A-粒度(Grit)	A	180	70	7.5	1.5	Ø3.5	#120 #200
NDF-180B-粒度(Grit)	B			6	2.1		
NDF-180C-粒度(Grit)	C			3.5	3.5		
NDF-180D-粒度(Grit)	D			4	4		
NDF-180E-粒度(Grit)	E			3.4	3.4		
NDF-180S-粒度(Grit)	5支組套裝/5 Pieces/Set(以上型號同粒度各1支)						

NDF200 精密型鑽石銼刀 Needle Diamond File

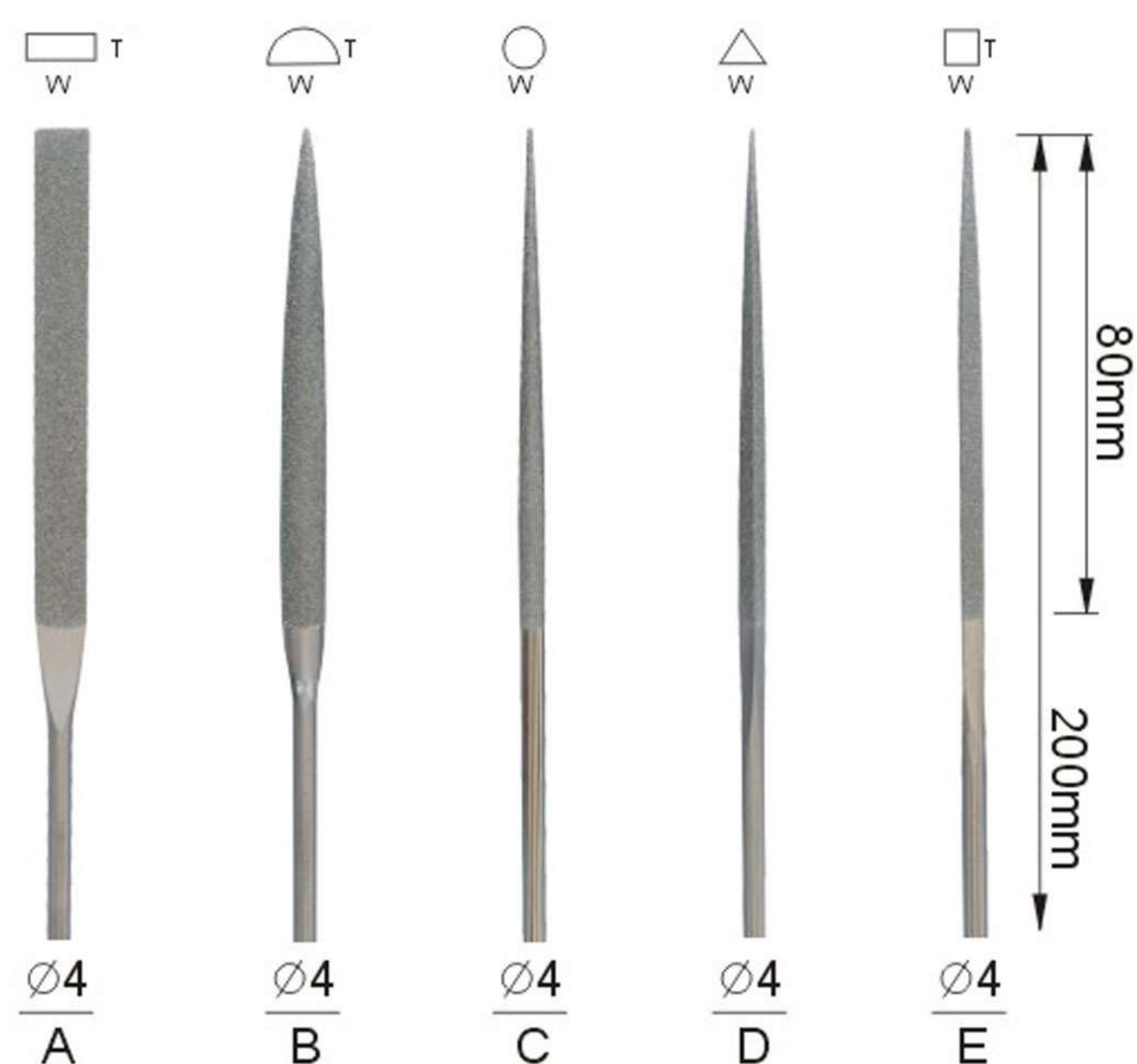

訂購編號 Order No.	形狀 Shape	全長 L	鑽石長度 B	寬度 W	厚度 T	柄徑 Shank	粒度 Grit
NDF-200A-粒度(Grit)	A	200	80	8.5	1.6	Ø4	#120 #200 #400
NDF-200B-粒度(Grit)	B			7	2.5		
NDF-200C-粒度(Grit)	C			4	4		
NDF-200D-粒度(Grit)	D			5	5		
NDF-200E-粒度(Grit)	E			3.5	3.5		
NDF-200S-粒度(Grit)	5支組套裝/5 Pieces/Set(以上型號同粒度各1支)						

MTDF80 機械用平斜鑽石銼刀 Machine Taper Diamond Files For Equipments

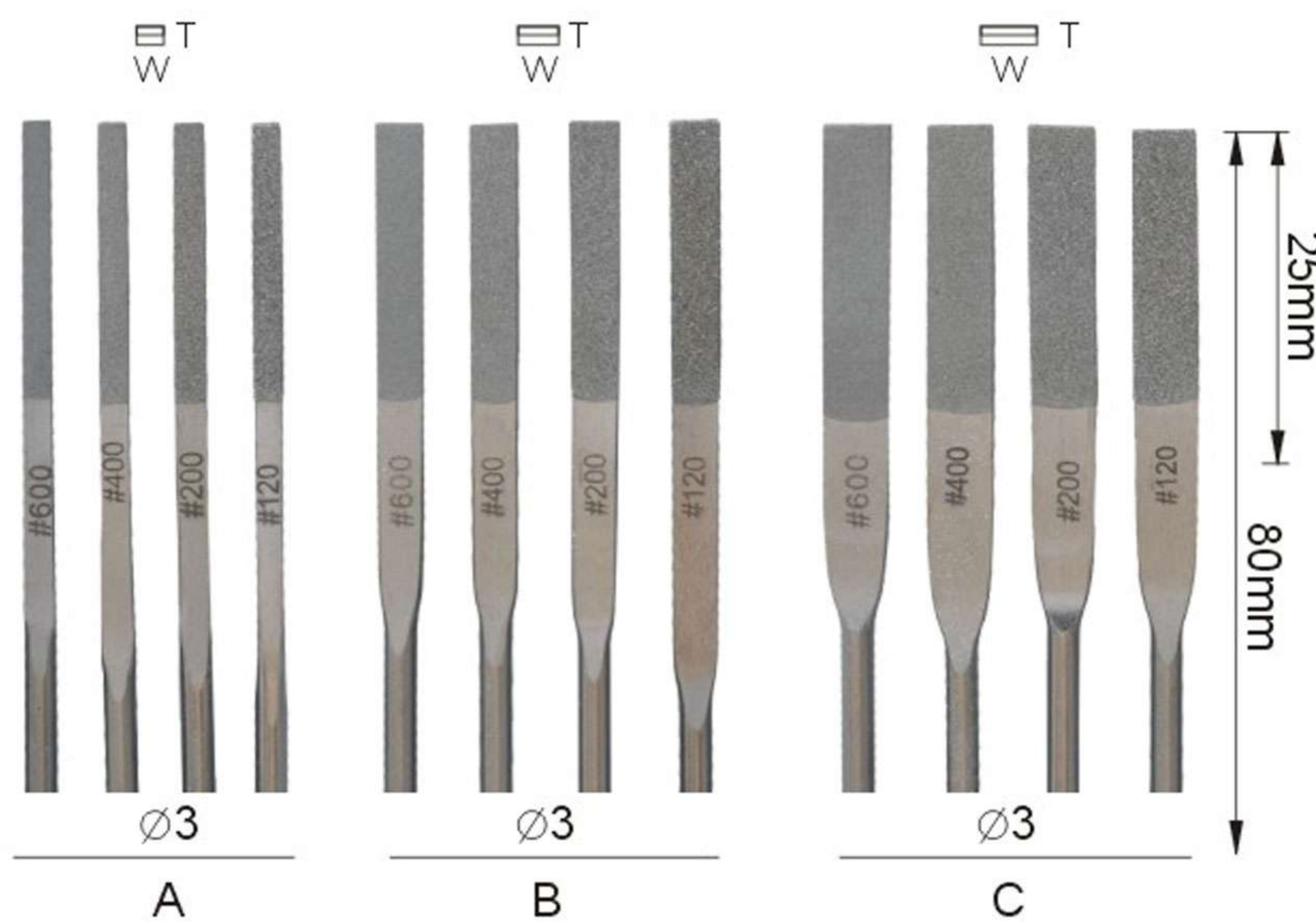

訂購編號 Order No.	形狀 Shape	全長 L	鑽石長度 B	寬度 W	厚度 T	柄徑 Shank	粒度 Grit
MTDF-80A-120	A	80	25	3	0.5~1.4	Ø3	#120
MTDF-80A-200							#200
MTDF-80A-400							#400
MTDF-80A-600							#600
MTDF-80B-120	B			4			#120
MTDF-80B-200							#200
MTDF-80B-400							#400
MTDF-80B-600							#600
MTDF-80C-120	C			6			#120
MTDF-80C-200							#200
MTDF-80C-400							#400
MTDF-80C-600							#600
MTDF-80S	12支組套裝/12 Pieces/Set(以上型號各1支)						

相關工具



MTDFFA 鑽石彈性銼刀片 Machine Taper Diamond Flexible Files

Machine Taper Diamond Flexible Files

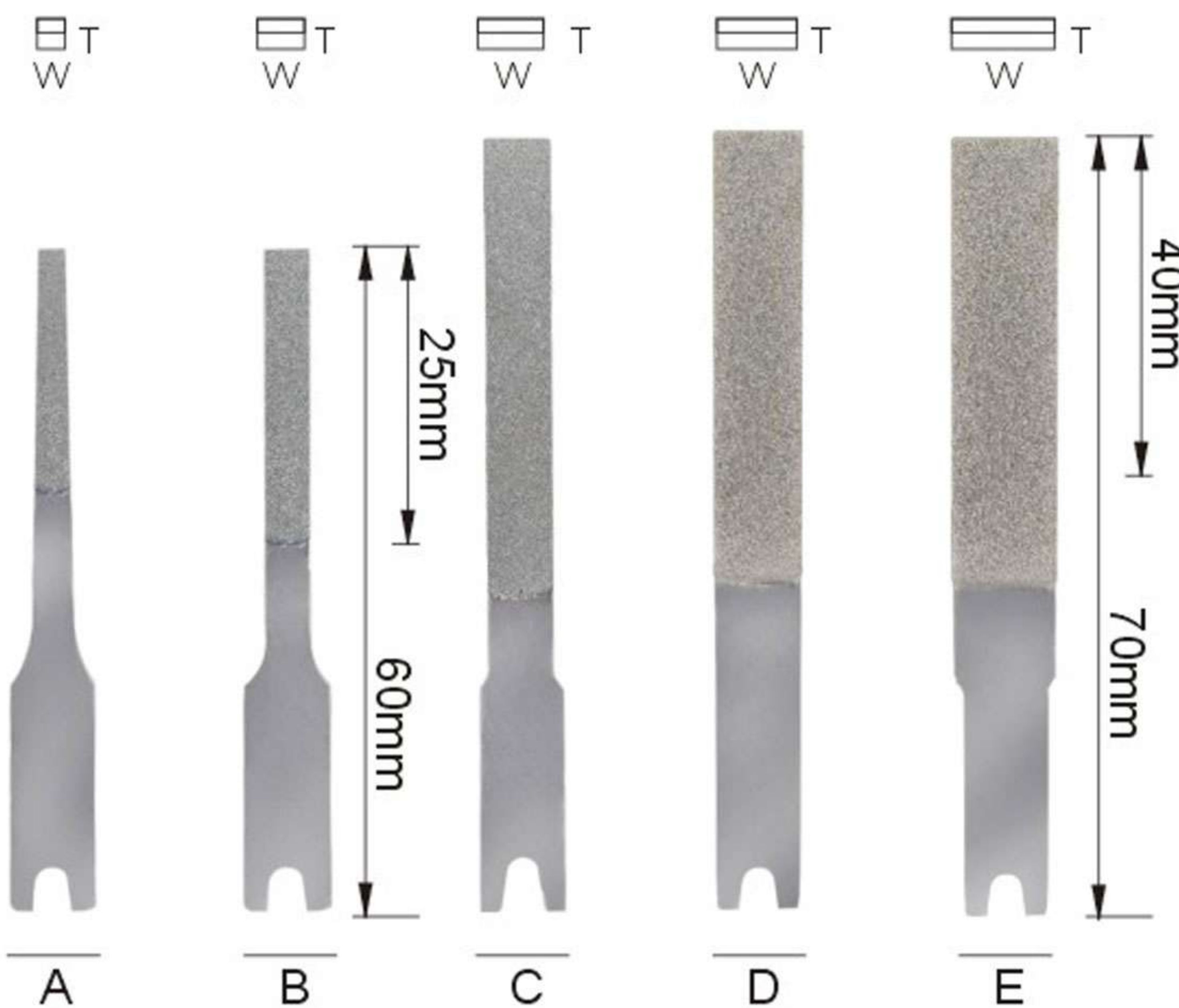

訂購編號 Order No.	形狀 Shape	全長 L	鑽石長度 B	寬度 W	厚度 T	粒度 Grit
MTDF-FAA-粒度(Grit)	A	60	25	2~6	0.5~1.0	#150 #200 #400 #600
MTDF-FAB-粒度(Grit)	B			4		
MTDF-FAC-粒度(Grit)	C	70	40	6		
MTDF-FAD-粒度(Grit)	D			8		
MTDF-FAE-粒度(Grit)	E			10		

相關工具



HDDF215 鐵工用鑽石銼刀 Heavy Duty Diamond Files

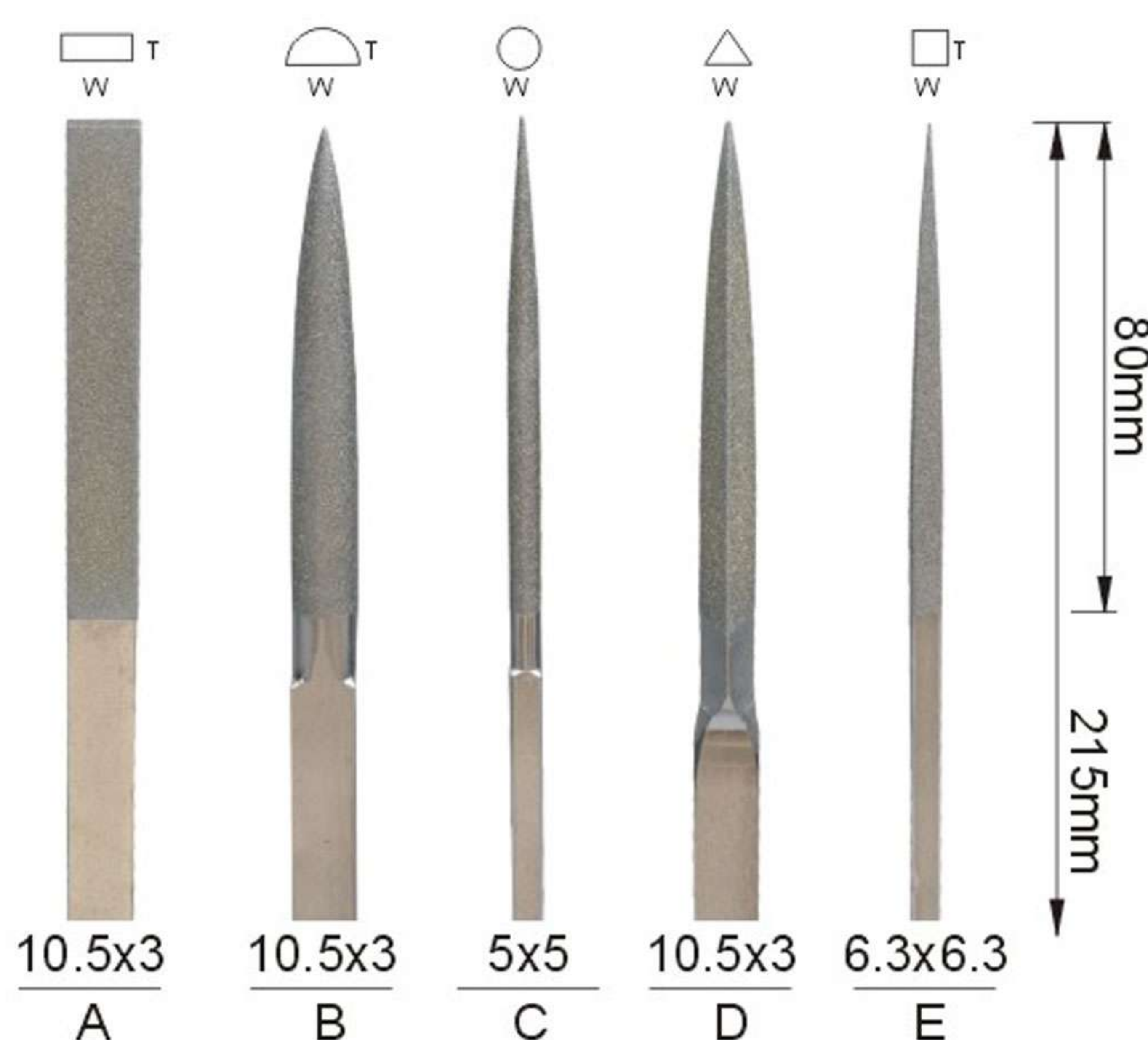

訂購編號 Order No.	形狀 Shape	全長 L	鑽石長度 B	寬度 W	厚度 T	柄徑 Shank	粒度 Grit
HDDF-215A-100	A	215	80	11	3.5	10.5x3	#120 #200 #400
HDDF-215B-100	B			10.5	4.4	10.5x3	
HDDF-215C-100	C			5	5	5x5	
HDDF-215D-100	D			7.7	7.7	10.5x3	
HDDF-215E-100	E			5.1	5.1	5x5	
HDDF-215S-100	5支組套裝/5 Pieces/Set(以上型號同粒度各1支)						

鑽石銼刀系列 Diamond File Series

RDFA140 異型鑽石銼刀 Radian Diamond Files

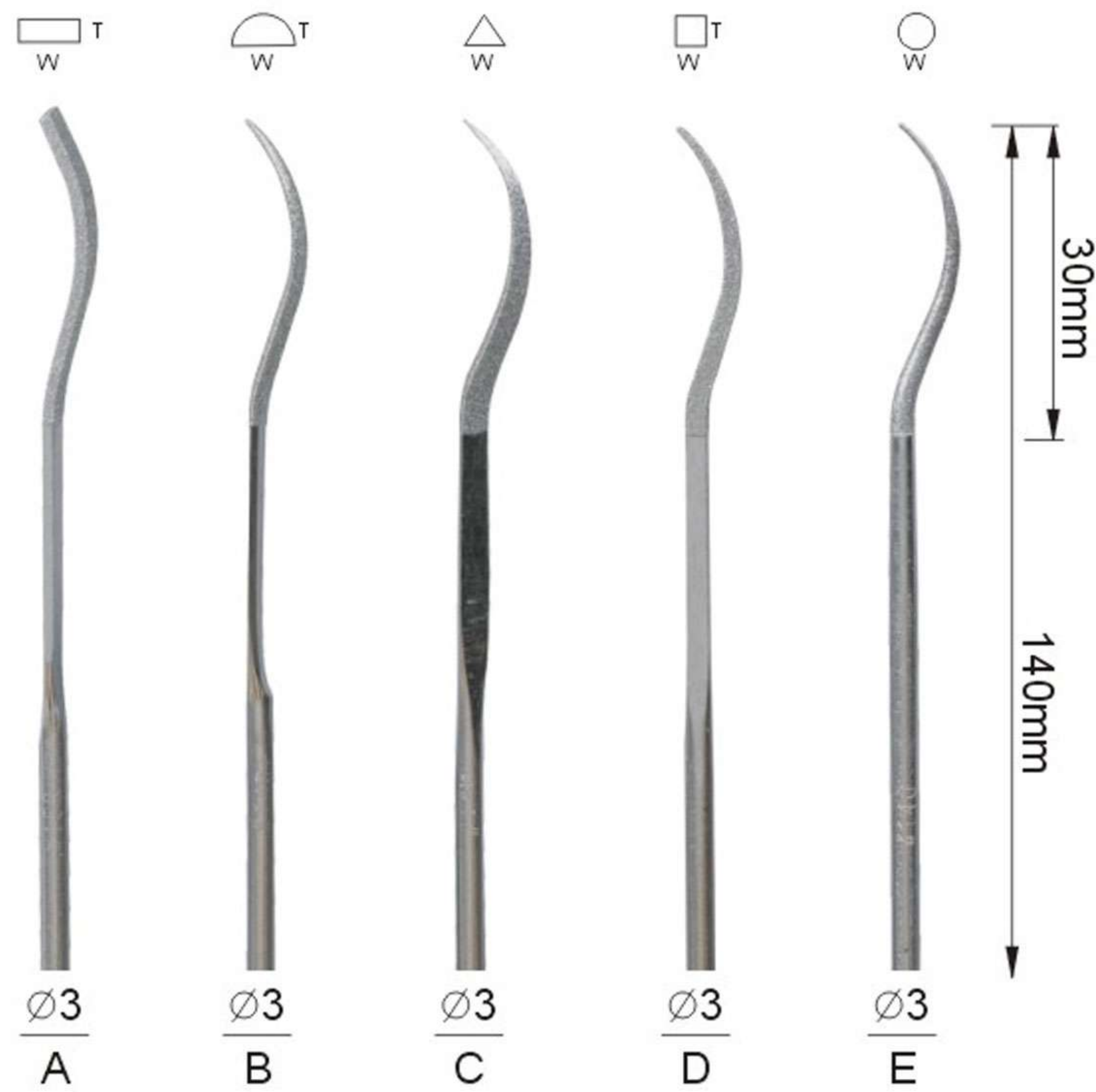

訂購編號 Order No.	形狀 Shape	全長 L	鑽石長度 B	寬度 W	厚度 T	柄徑 Shank	粒度 Grit
RDFA-140A-粒度(Grit)	A	140	30	6	1.5	∅3	#150
RDFA-140B-粒度(Grit)	B			5	2		
RDFA-140C-粒度(Grit)	C			3.5	3.5		
RDFA-140D-粒度(Grit)	D			2.5	2.5		
RDFA-140E-粒度(Grit)	E			3	3		
RDFA-140S-粒度(Grit)	5支組套裝/5 Pieces/Set(以上型號同粒度各1支)						

RDFB150 異型鑽石雙頭銼刀 Radian Diamond Files

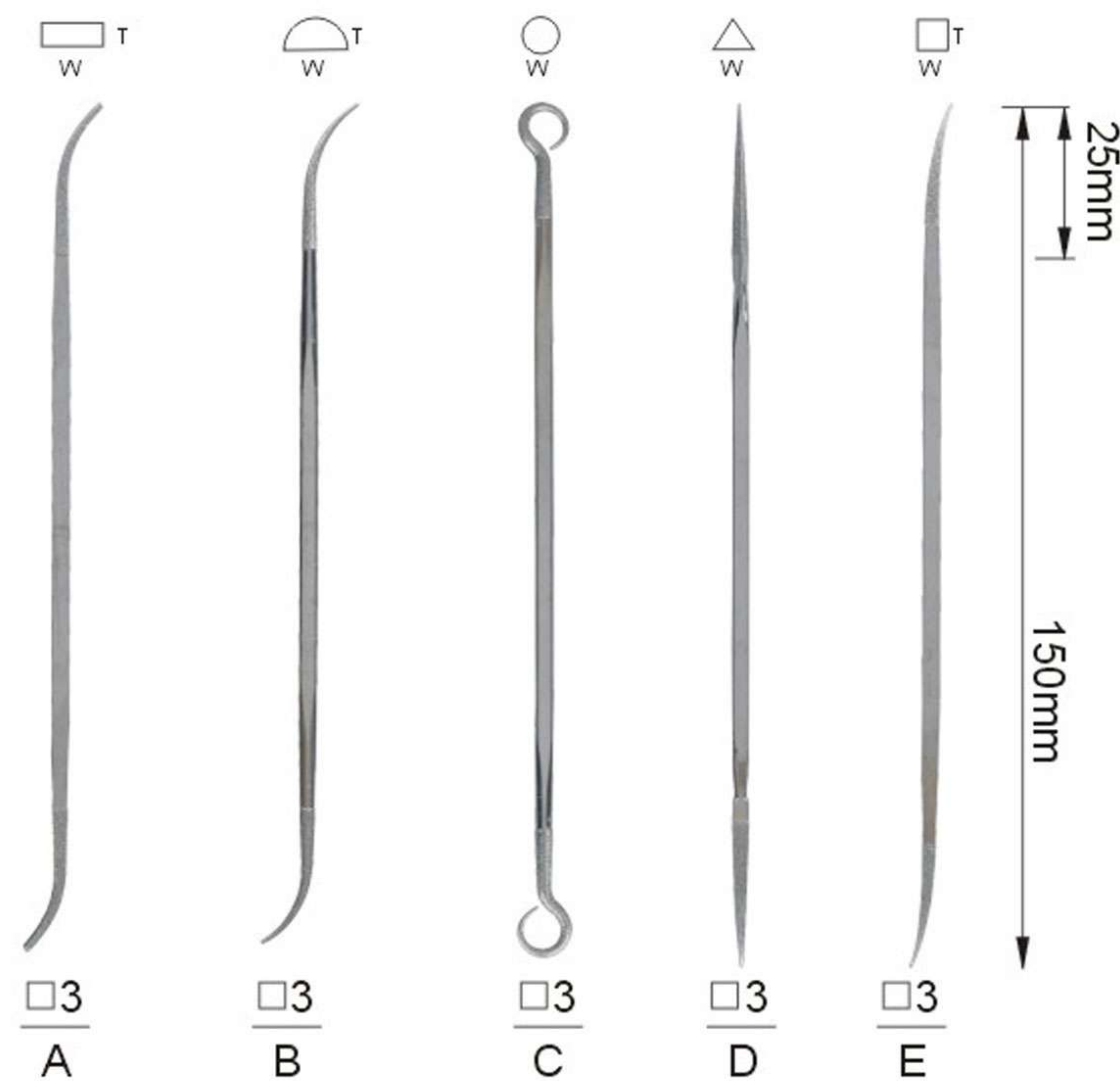

訂購編號 Order No.	形狀 Shape	全長 L	鑽石長度 B	寬度 W	厚度 T	柄徑 Shank	粒度 Grit
RDFB-150A-粒度(Grit)	A	150	25	3	2	∅3	#120
RDFB-150B-粒度(Grit)	B		25	2	2		
RDFB-150C-粒度(Grit)	C		20	2	2		
RDFB-150D-粒度(Grit)	D		25	3	3		
RDFB-150E-粒度(Grit)	E		20	2.5	2.5		
RDFB-150S-粒度(Grit)	5支組套裝/5 Pieces/Set(以上型號同粒度各1支)						

RDFC150 異型鑽石銼刀 Radian Diamond Files

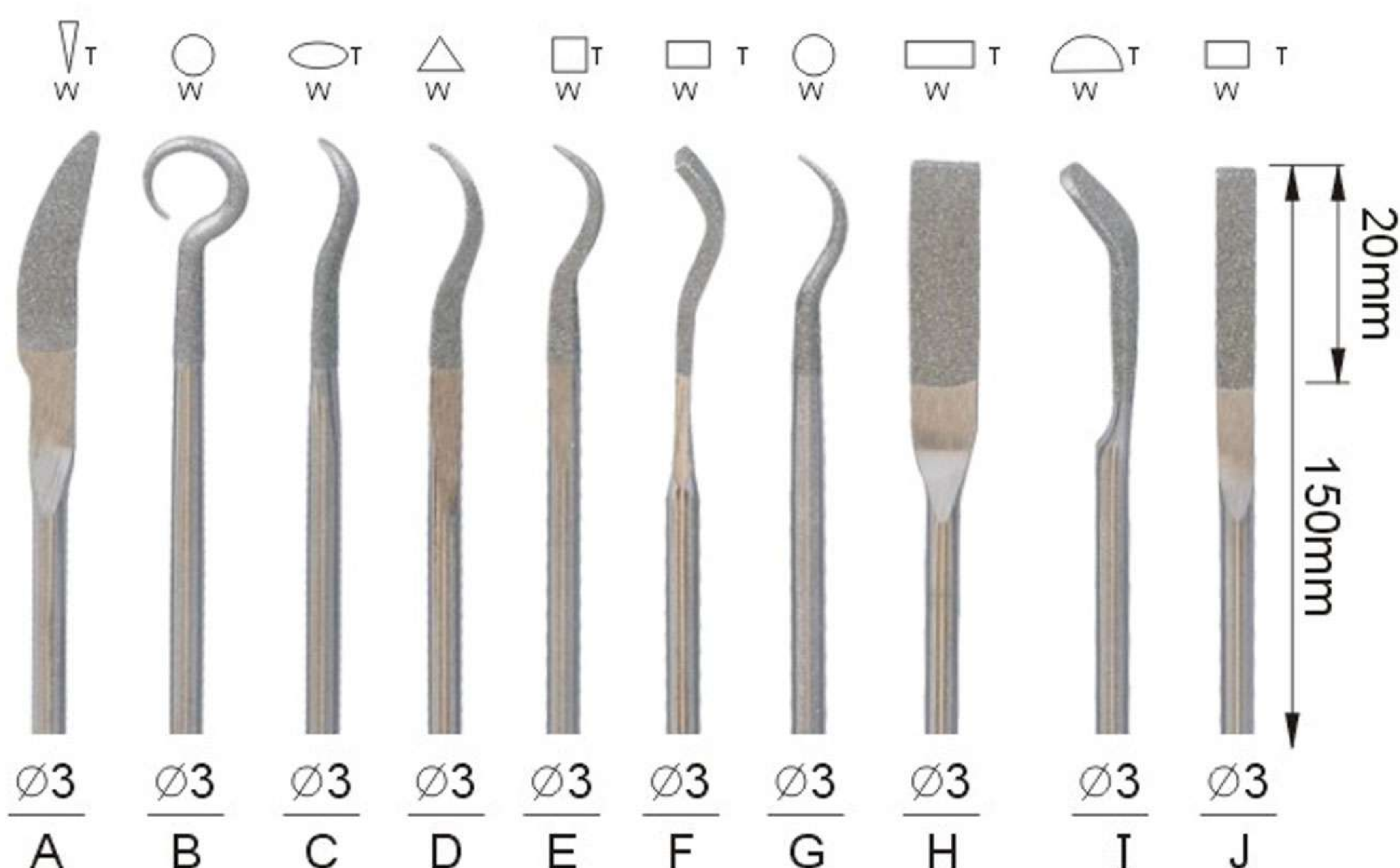

訂購編號 Order No.	形狀 Shape	全長 L	鑽石長度 B	寬度 W	厚度 T	柄徑 Shank	粒度 Grit
RDFC-150A-粒度(Grit)	A	140	20	5	1.2	∅3	#120
RDFC-150B-粒度(Grit)	B			2	2		
RDFC-150C-粒度(Grit)	C			4	2		
RDFC-150D-粒度(Grit)	D			3	3		
RDFC-150E-粒度(Grit)	E			2.5	2.5		
RDFC-150F-粒度(Grit)	F			3	1.2		
RDFC-150G-粒度(Grit)	G			2	2		
RDFC-150H-粒度(Grit)	H			6	1.2		
RDFC-150I-粒度(Grit)	I			5	1.6		
RDFC-150J-粒度(Grit)	J			3	1.2		
RDFC-150S-粒度(Grit)	10支組套裝/10 Pieces/Set(以上型號同粒度各1支)						

MRDF65 機械用異型鑽石銼刀 Machine Radian Diamond Files For Equipments

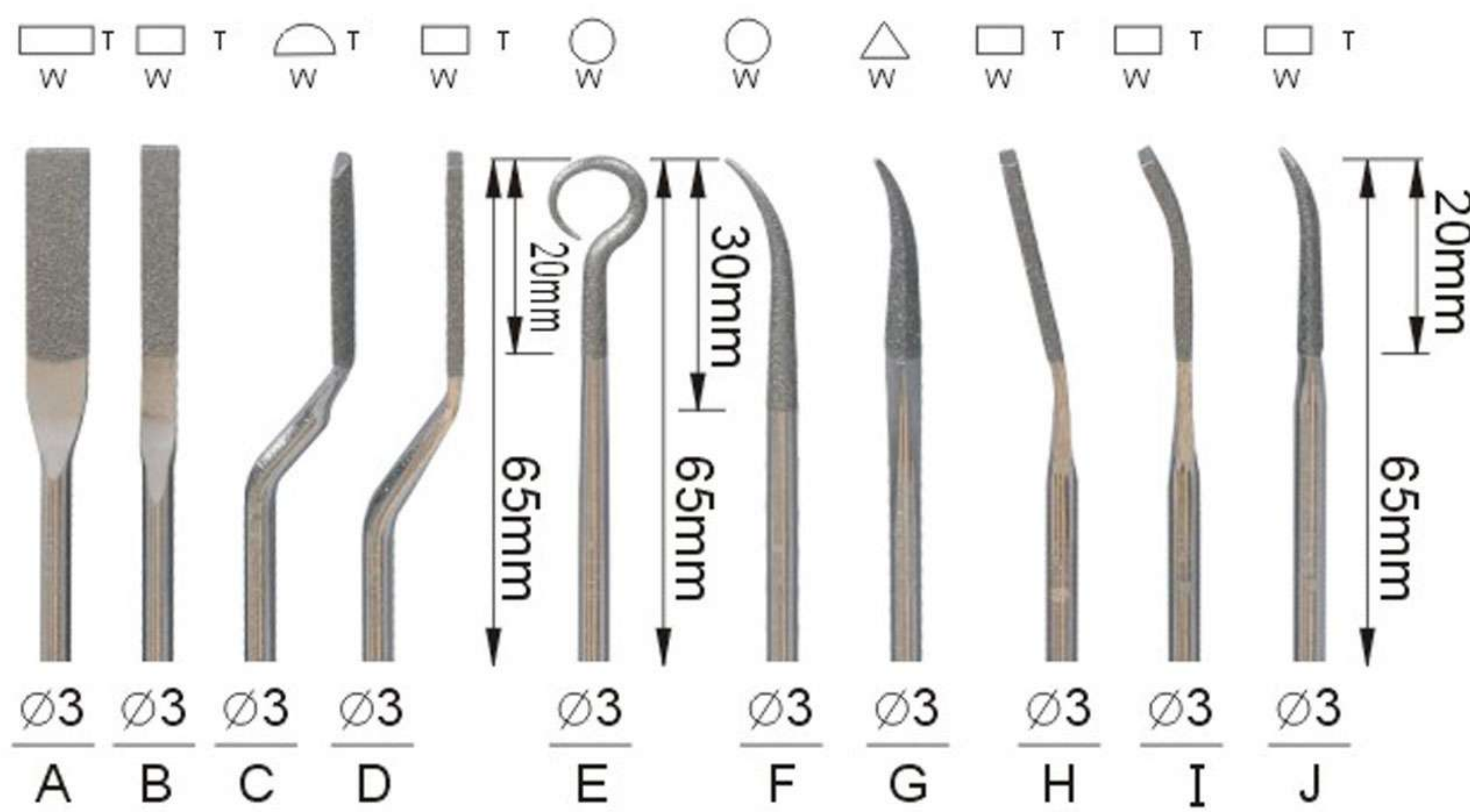

訂購編號 Order No.	形狀 Shape	全長 L	鑽石長度 B	寬度 W	厚度 T	柄徑 Shank	粒度 Grit	
MRDF-65A-粒度(Grit)	A	65	20	5.8	1.2	∅3	#150 #200	
MRDF-65B-粒度(Grit)	B			3.2	1.4			
MRDF-65C-粒度(Grit)	C			5	2			
MRDF-65D-粒度(Grit)	D			3.2	1.4			
MRDF-65E-粒度(Grit)	E			3	3			
MRDF-65F-粒度(Grit)	F			30	3			3
MRDF-65G-粒度(Grit)	G			3	3			
MRDF-65H-粒度(Grit)	H			3.2	1.4			
MRDF-65I-粒度(Grit)	I			3.2	1.4			
MRDF-65J-粒度(Grit)	J			4	2			
MRDF-65S-粒度(Grit)	10支組套裝/10 Pieces/Set(以上型號同粒度各1支)							

PTDF 搪孔棒 Internal Boring Diamond Files

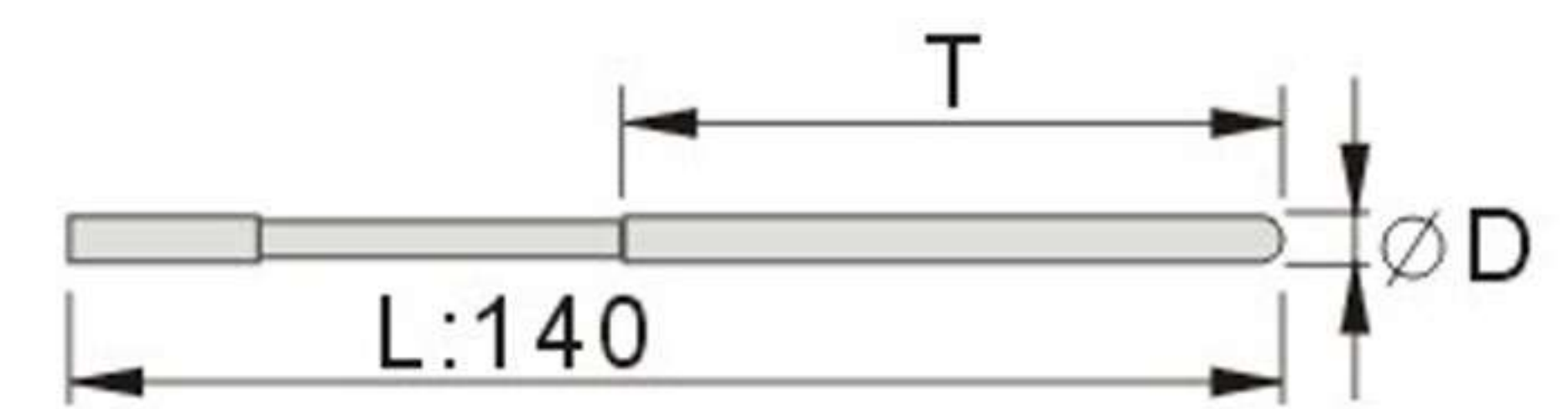

訂購編號 Order No.	外徑 OD	全長 L	鑽石長度 B	粒度 Grit
PTDF-140-10-100	1.0	140	80	#100
PTDF-140-11-100	1.1			
PTDF-140-12-100	1.2			
PTDF-140-13-100	1.3			
PTDF-140-14-100	1.4			

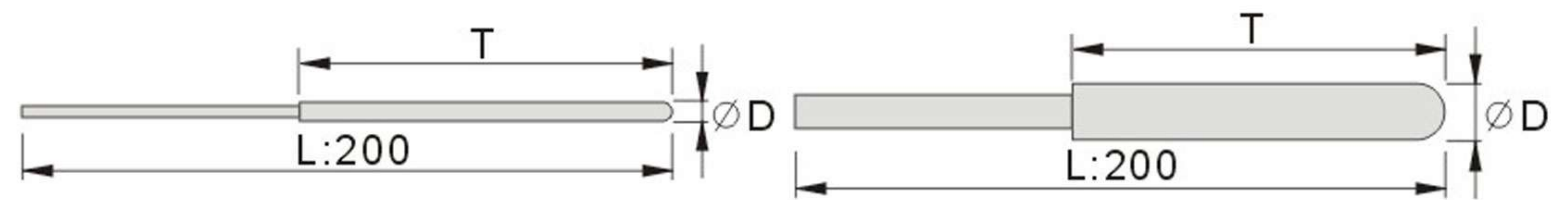

訂購編號 Order No.	外徑 OD	全長 L	鑽石長度 B	粒度 Grit
PTDF-200-(15~50)-100	1.5~5.0	200	120	#100
PTDF-200-(51~60)-100	5.1~6.0			
PTDF-200-(61~70)-100	6.1~7.0			

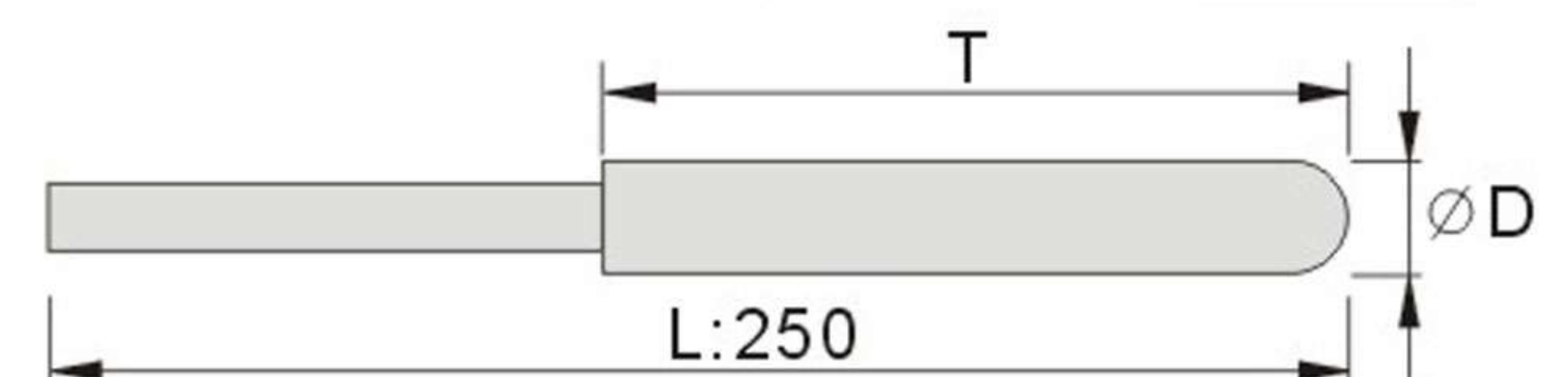

訂購編號 Order No.	外徑 OD	全長 L	鑽石長度 B	粒度 Grit
PTDF-250-(71~80)-100	7.1~8.0	250	120	#100
PTDF-250-(81~90)-100	8.1~9.0			
PTDF-250-(91~100)-100	9.1~10.0			

鑽石工具系列 Diamond File Series

DDC

圓錐修刀 Coned Diamond Dressers



適用於傳統砂輪(PA,WA,GA...等)精密研修，可搭配以下產品使用。
Application: For surface dressing of Aluminum oxide grinding wheels, like PA, WA, GA... wheels.
It is perfect to use together with following equipments.



沖子成型器、角度修整器、厚度修整器、角度成型器...等
Punch former, angle dresser, duplex dresser and angle sine dresser...

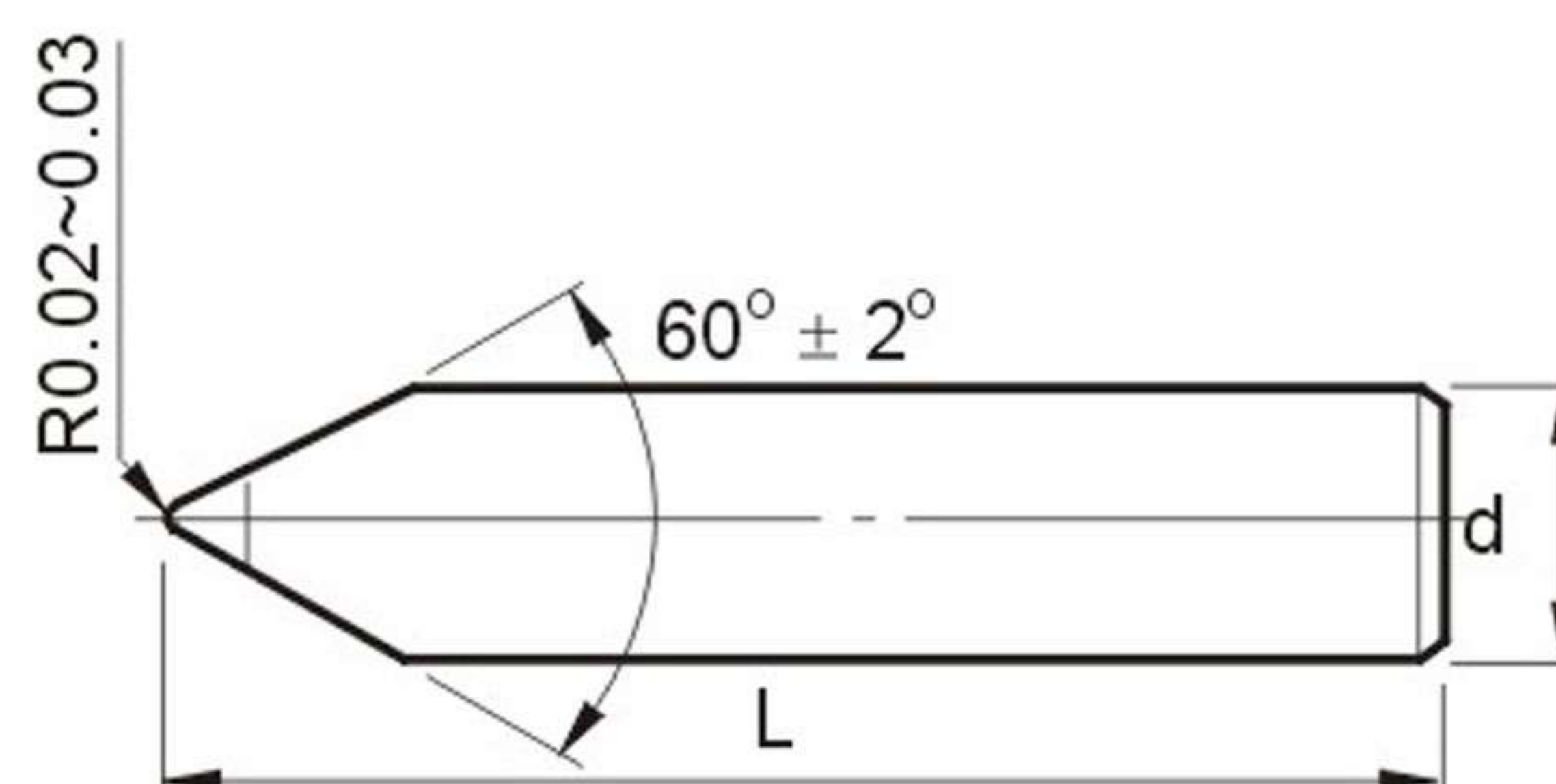

材質(柄) SK4 頂端 天然鑽石
Material (Shank): SK4 Tip: Natural Diamond

訂購代號	柄徑	全長
Order No.	Diameter	Length
DDC-001	3.175	25.4
DDC-002	3.175	50
DDC-003	6.35	50
DDC-004	9.53	50
DDC-005	10	50

鑽石工具系列

DDP

角錐修刀 Pyramid Dressers



001 002 003 004

材質(柄) SK4 頂端 天然鑽石
Material (Shank): SK4 Tip: Natural Diamond

訂購代號	柄徑	全長
Order No.	Diameter	Length
DDP-001	Ø10	50
DDP-002	Ø12	50L / 100L
DDP-003	Ø6	22L
DDP-004	Ø8	23L

適用於內圓砂輪精修，以上為常用規格
Application: For precision dressing of internal grinding wheels.

DDM

多石修刀 Multi Point Diamond Dressers

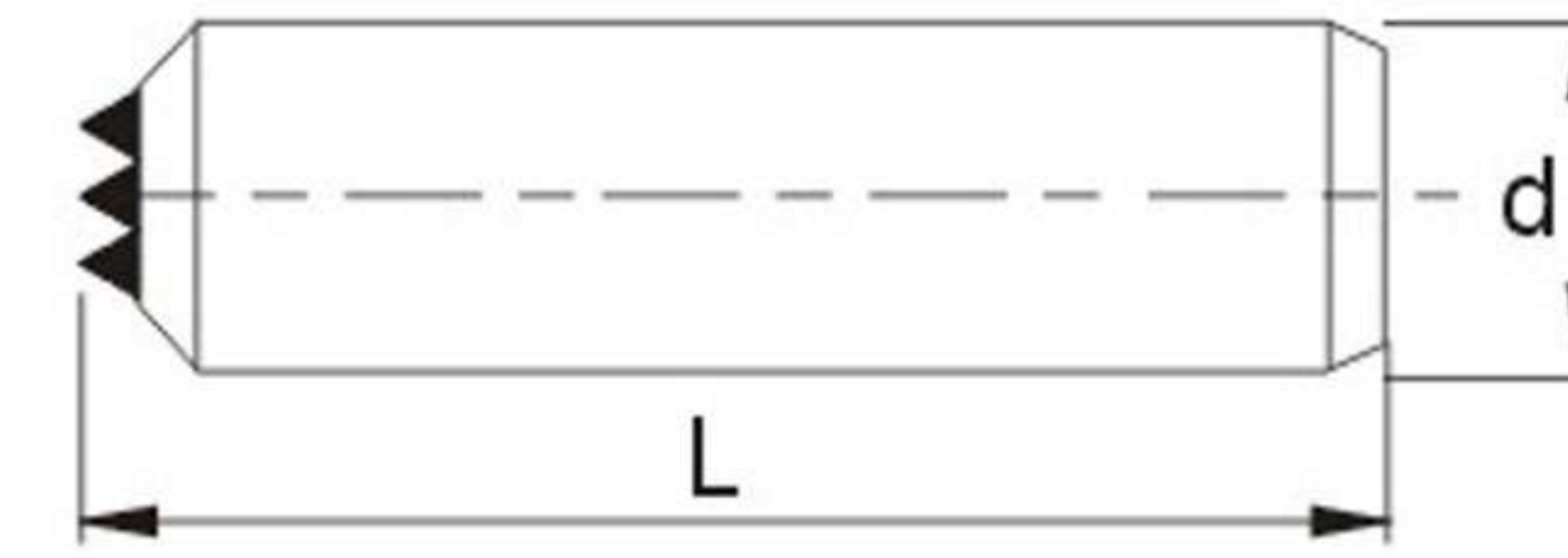

適用於傳統砂輪(PA,WA,GA...等平面研磨)

Application: For surface dressing of Aluminum oxide grinding wheels, like PA, WA, GA... wheels.

訂購代號 Order No.	鑽石顆數 Diamond Quantity	柄徑 Shank	鑽石分布 Diamond Distribution
DDM-03101	3	Ø12 x 100L	▲▲▲
DDM-03102	3		▲▲▲
DDM-05101	5		▲▲▲▲▲
DDM-06101	6		▲▲▲▲▲▲
DDM-07101	7		▲▲▲▲▲▲▲

DDS

單石修刀 Single Diamond Dressers

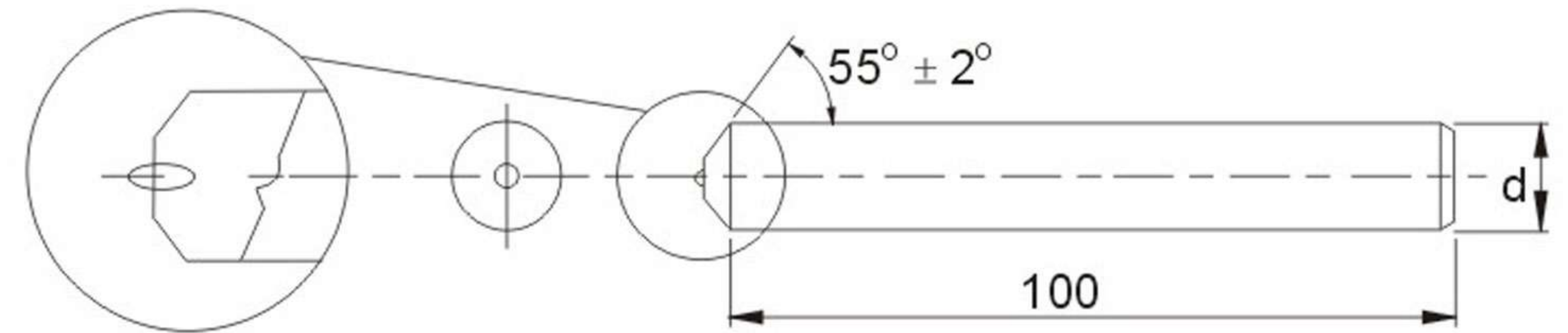

安裝及使用 / Installation and operation

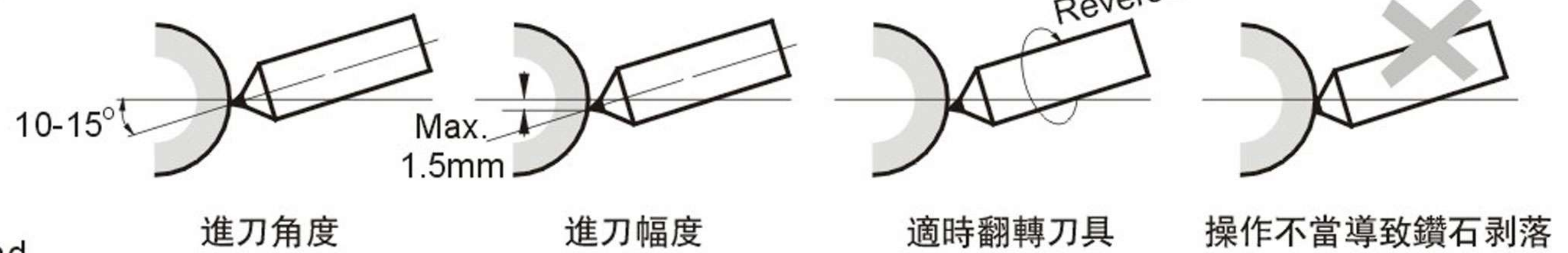

材質(柄) SK4
Material (Shank): SK4

頂端 天然鑽石
Tip: Natural Diamond

訂購代號 Order No.	鑽石番號 Diamond weight code	適用砂輪 Grinding Wheels Size(mm)	柄徑 Shank
DDS-010	#2 / 0.10cts	Ø150x25 or smaller	Ø10x80L (A)
DDS-012	#3 / 0.12cts		
DDS-015	#4 / 0.15cts		
DDS-018	#5 / 0.18cts		
DDS-020	#10 / 0.20cts		
DDS-025	#15 / 0.25cts	Ø150~Ø300x25	or Ø12x100L (B)
DDS-035	#20 / 0.35cts		
DDS-050	#25 / 0.50cts		
DDS-075	#33 / 0.75cts		
DDS-100	#50 / 1.0cts		
DDS-150	#75 / 1.5cts	Ø450~Ø600x50~100	
DDS-200	#100 / 2.0cts		

訂購範例 Order Ex DDS-020-A(or B)

鑽石工具系列 Diamond File Series

DDI

組合修刀 Impregnated Diamond Dressers

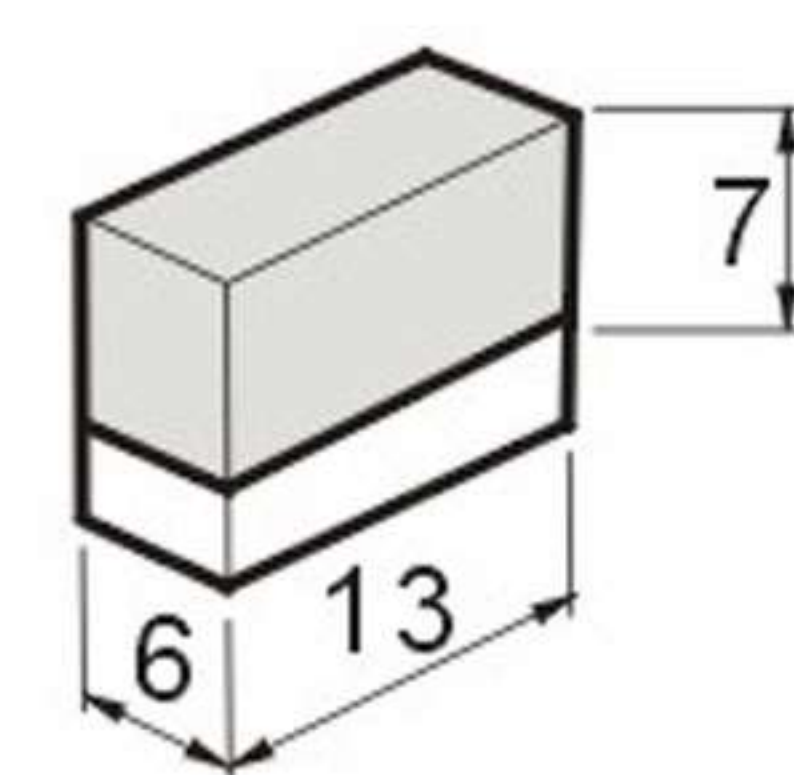

2A

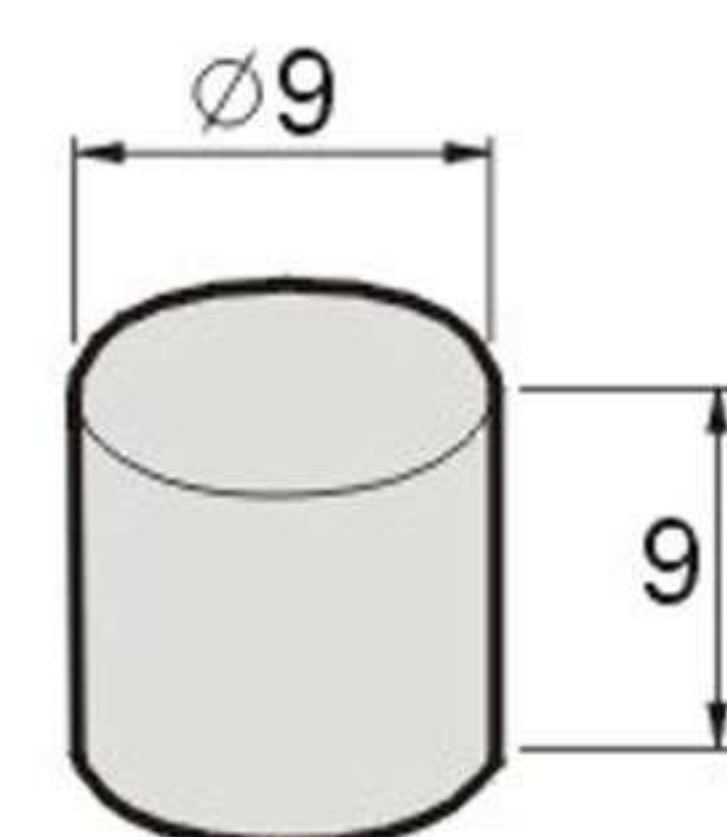

1C

訂購代號	粒度	齒塊	鐵柄形狀	鐵柄尺寸	適用範圍
Order No.	Grit	Diamond Tips	Type(Shank)	Shank	Applications
DDI-2AFC	F	2A		Ø12x100 Ø12X50	無心研磨、圓筒研磨 平面研磨 砂輪尺寸: Ø300x25~Ø500x63
DDI-2AMC	M				
DDI-2ARC	R				
DDI-2AFD	F				
DDI-2AMD	M				
DDI-2ARD	R				
DDI-1CFG	F	1C		Ø10x50(A) Ø12X50(B)	一般用途之研磨 砂輪尺寸: Ø300及以下
DDI-1CMG	M				For general purpose grinding. Wheel size
DDI-1CRG	R				Ø300 and smaller

鑽石工具系列

DDH

手持式結合修刀 Hand Diamond Dressers

訂購代號	粒度	鑽石齒塊	型式
Order No.	Grit Size	Diamond Tips	Form
DDH-01R DDH-01F	R F	2A	 總長/Total length:160mm
DDH-02R DDH-02F	R F	1A	 總長/Total length:160mm 方向① direction① or 方向② direction②

粒度說明 / Grit Instruction

鑽石粒度 Diamond Grit	適用被修整砂輪粒度 Grinding wheel grit in operation
R 粗目 Rough	#60以下(more Rough)
M 中目 Medium	#80~#120
F 細目 Fine	#150以上(more fine)

BDS/BBS 鑽石磨棒 Diamond Burrs

3mm柄套裝組系列10支套裝組 3mm Shank Kit 10 Pieces / Set

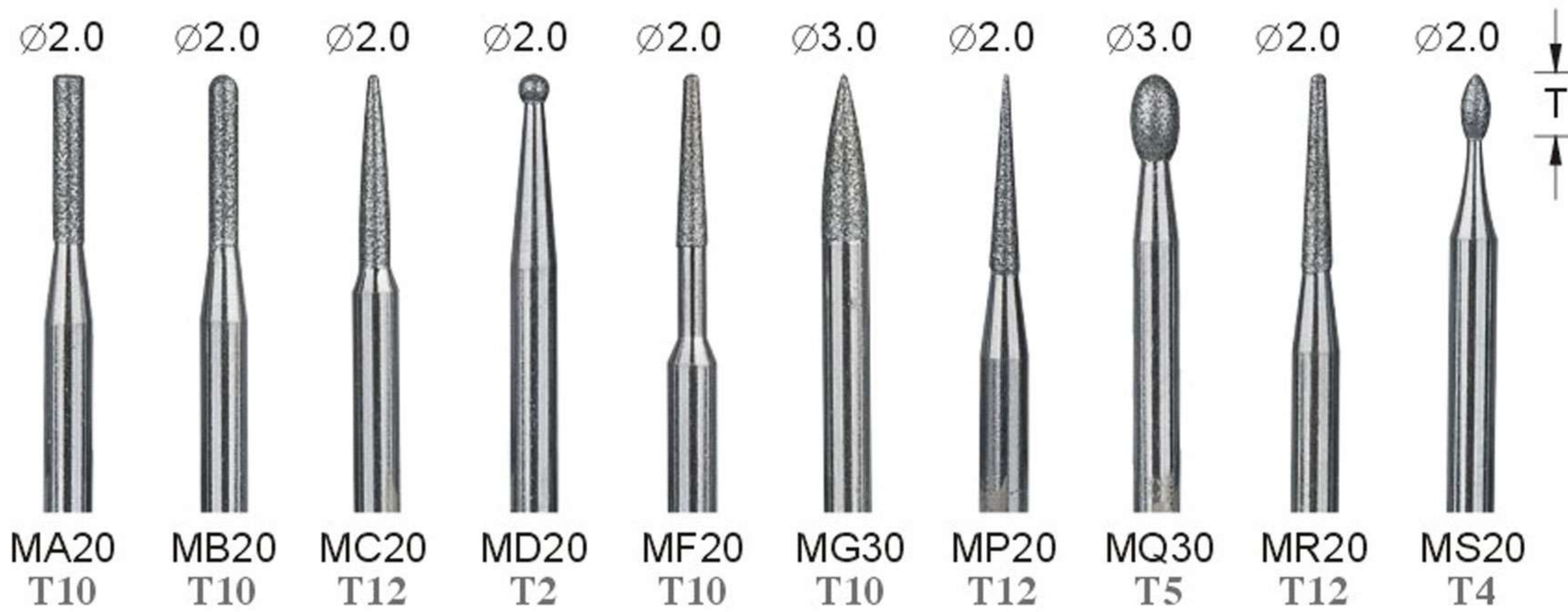

訂購編號 BDS-3-10(DIAMOND)
Order No. BBS-3-10(CBN)

2.34mm柄套裝組系列20支套裝組 2.34mm Shank Kit 20 Pieces / Set

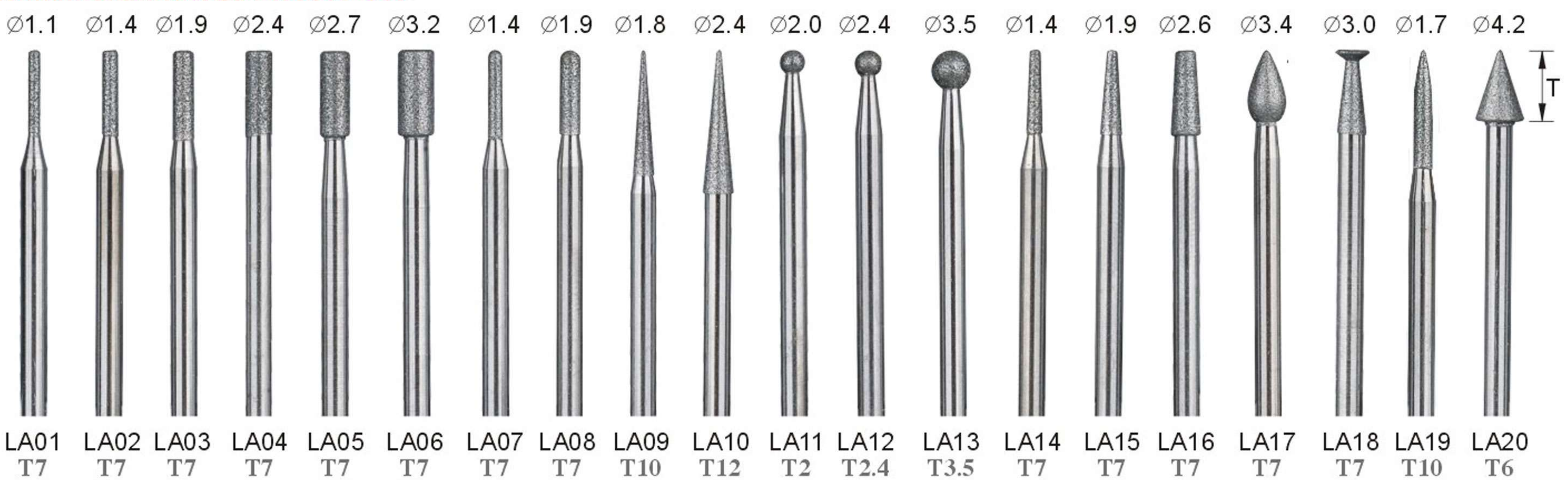

訂購編號 BDS-234-20(DIAMOND)
Order No.

3mm柄套裝組系列30支套裝組 3mm Shank Kit 30 Pieces / Set

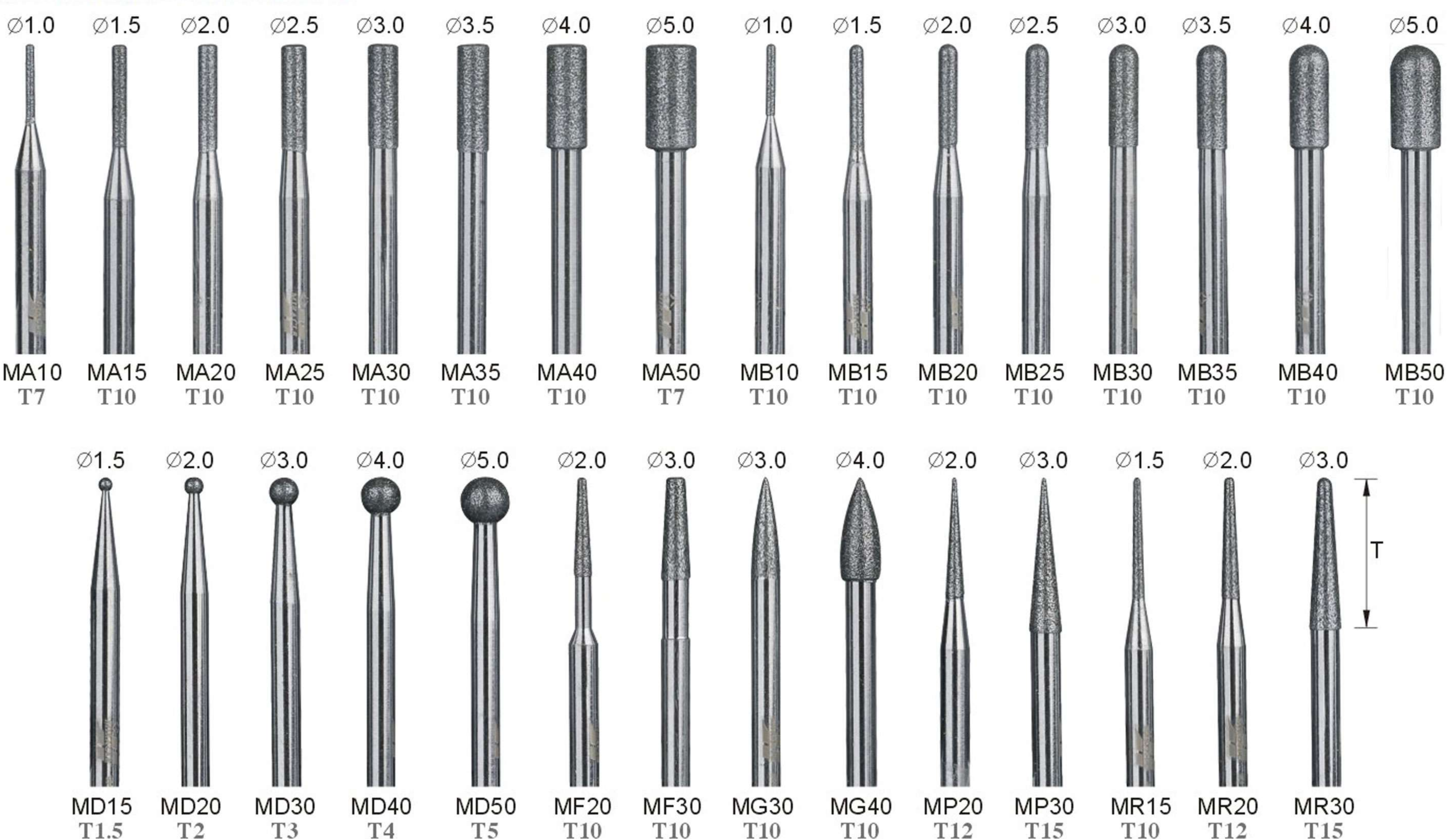

訂購編號 BDS-3-30(DIAMOND)
Order No. BBS-3-30(CBN)

鑽石磨棒 Diamond Burrs

M

鑽石磨棒 Diamond Burrs

圓柱形
Cylindrical Type

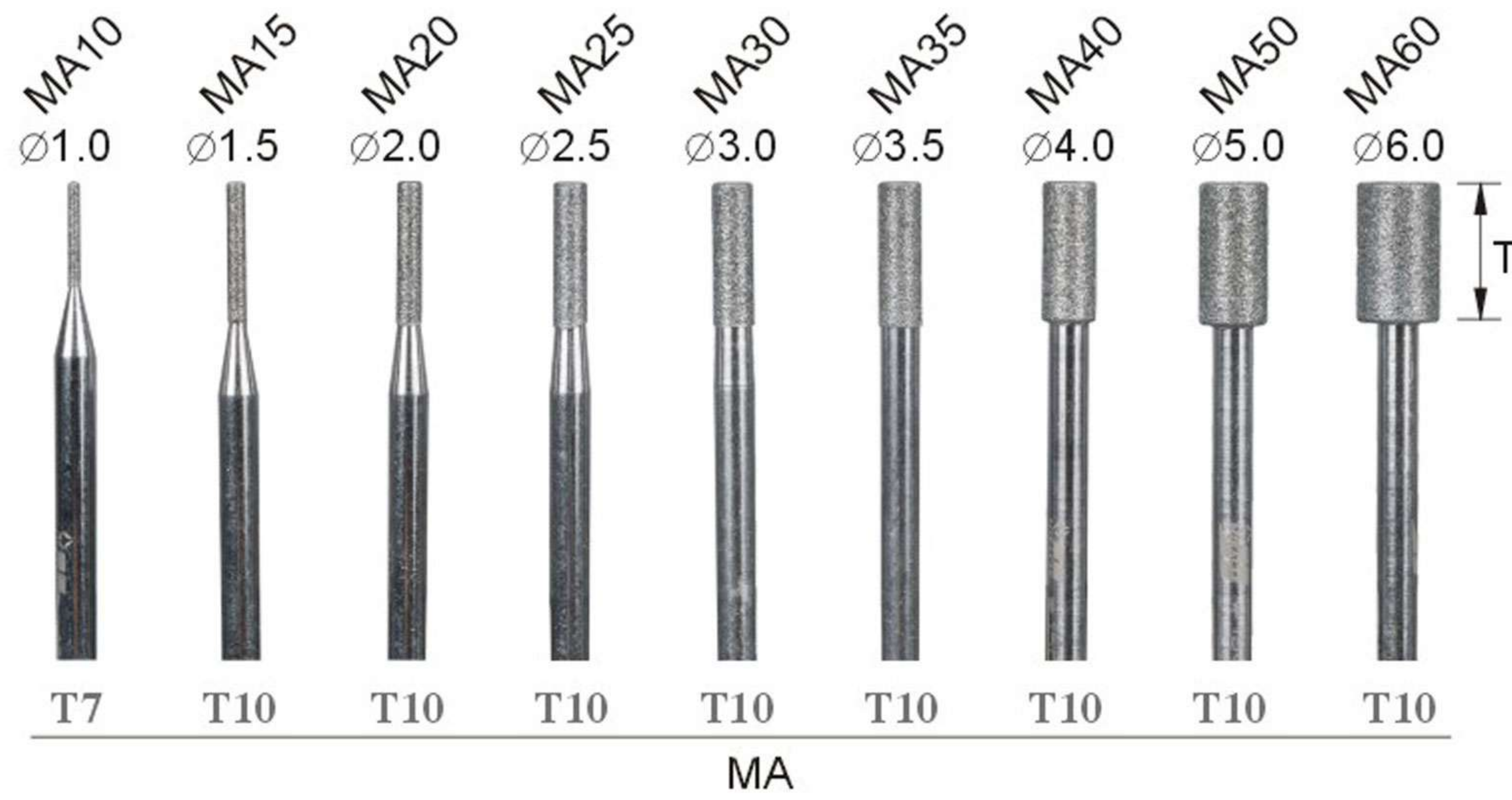

桃形
Round End Taper Type

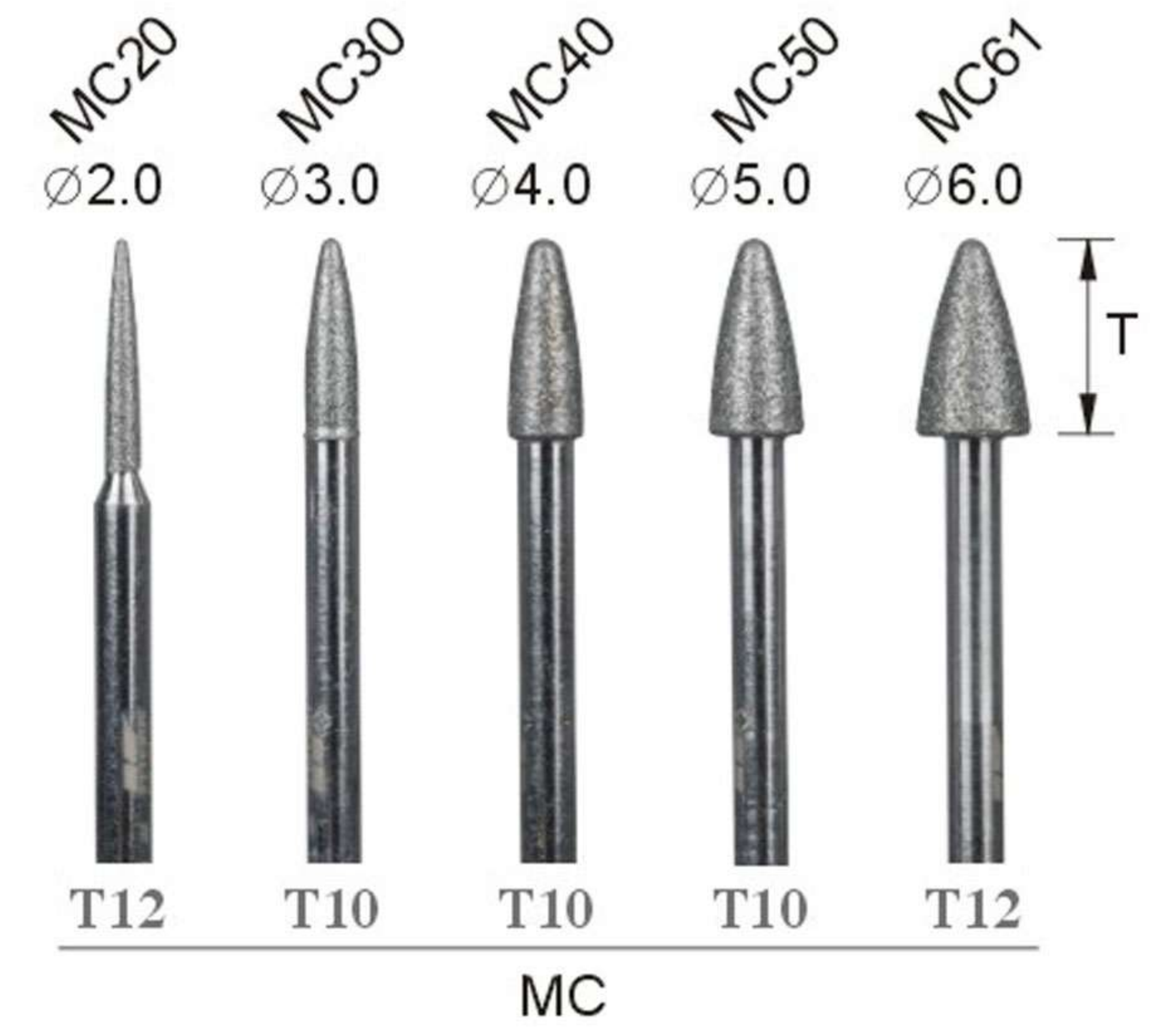

R形
Round End Type

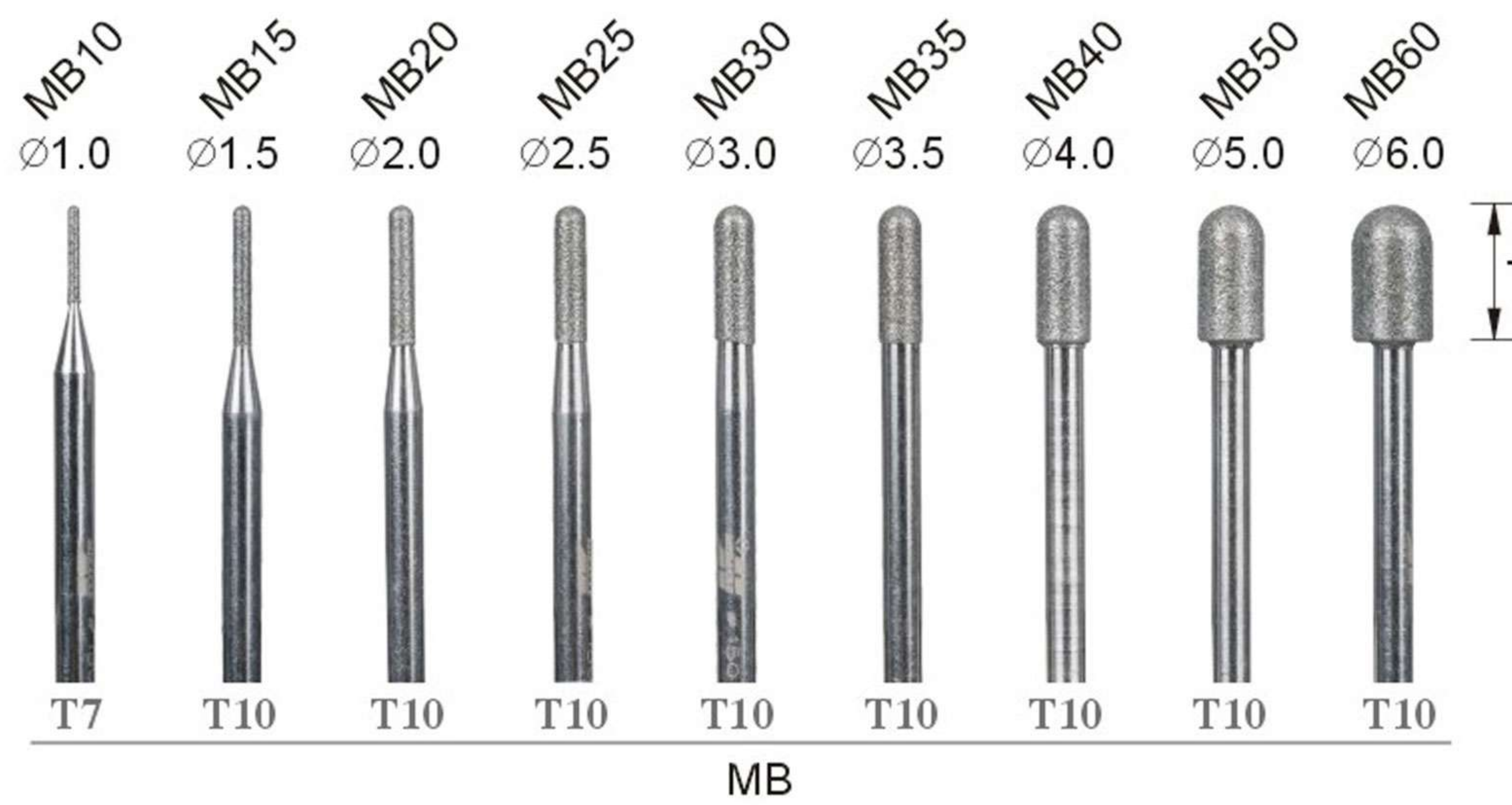

平斜形
Flat End Type



球形
Ball Type



桃尖形
Needle End Taper Type

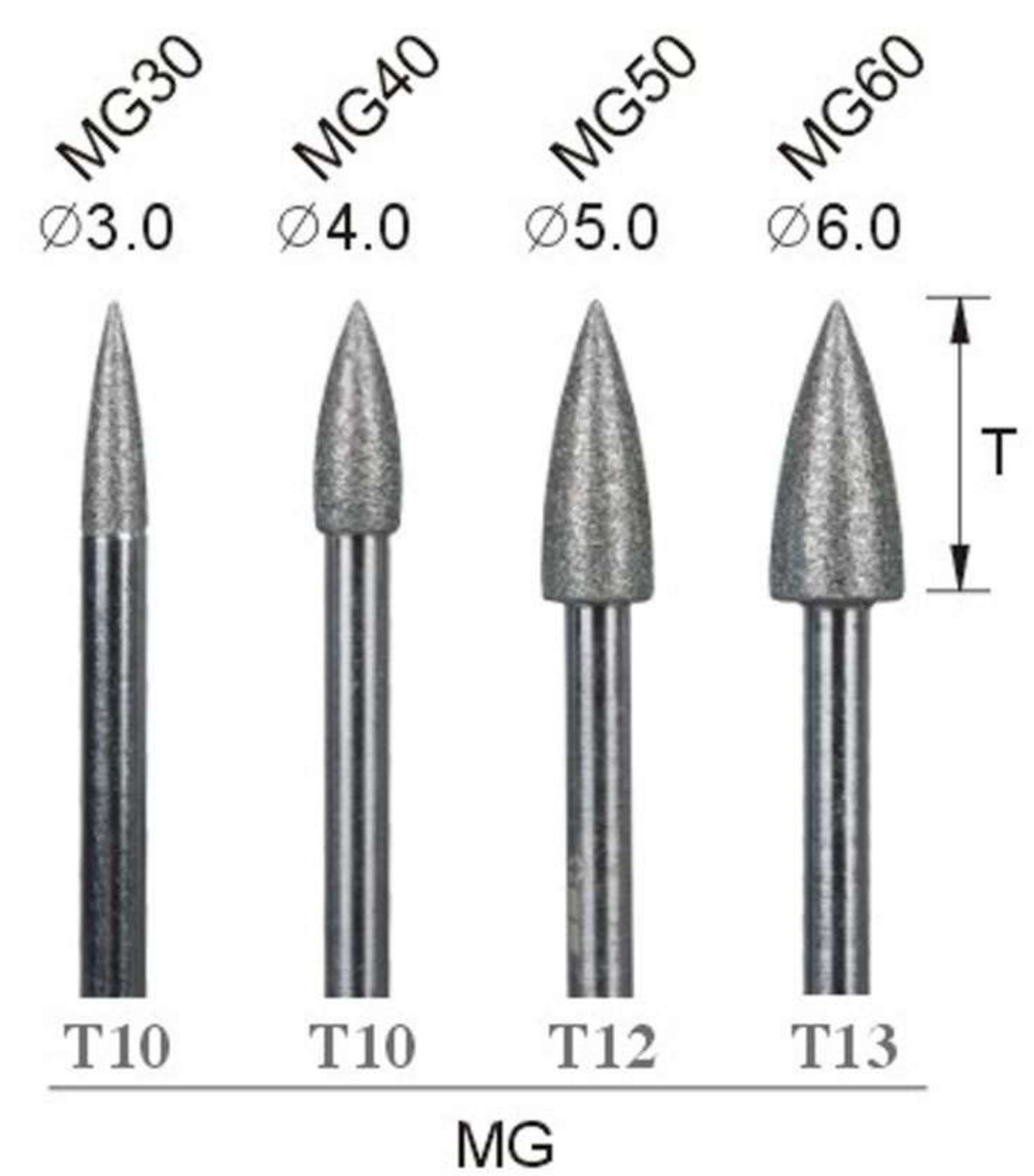

■ OD 1.0~3.5#150 OD 4.0~above #120 ■ 5支裝/一組(5pcs/set)

鑽石工具系列

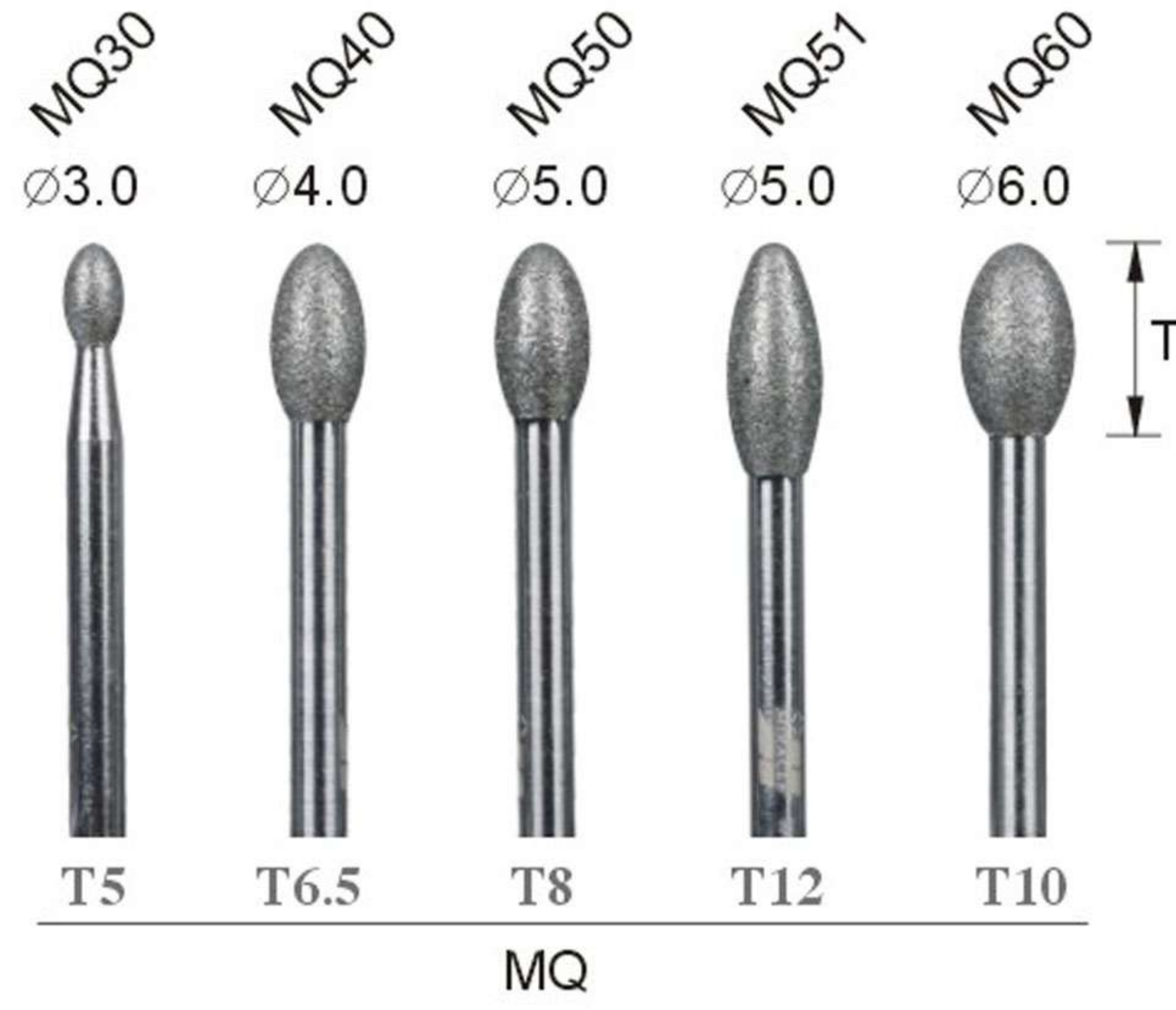
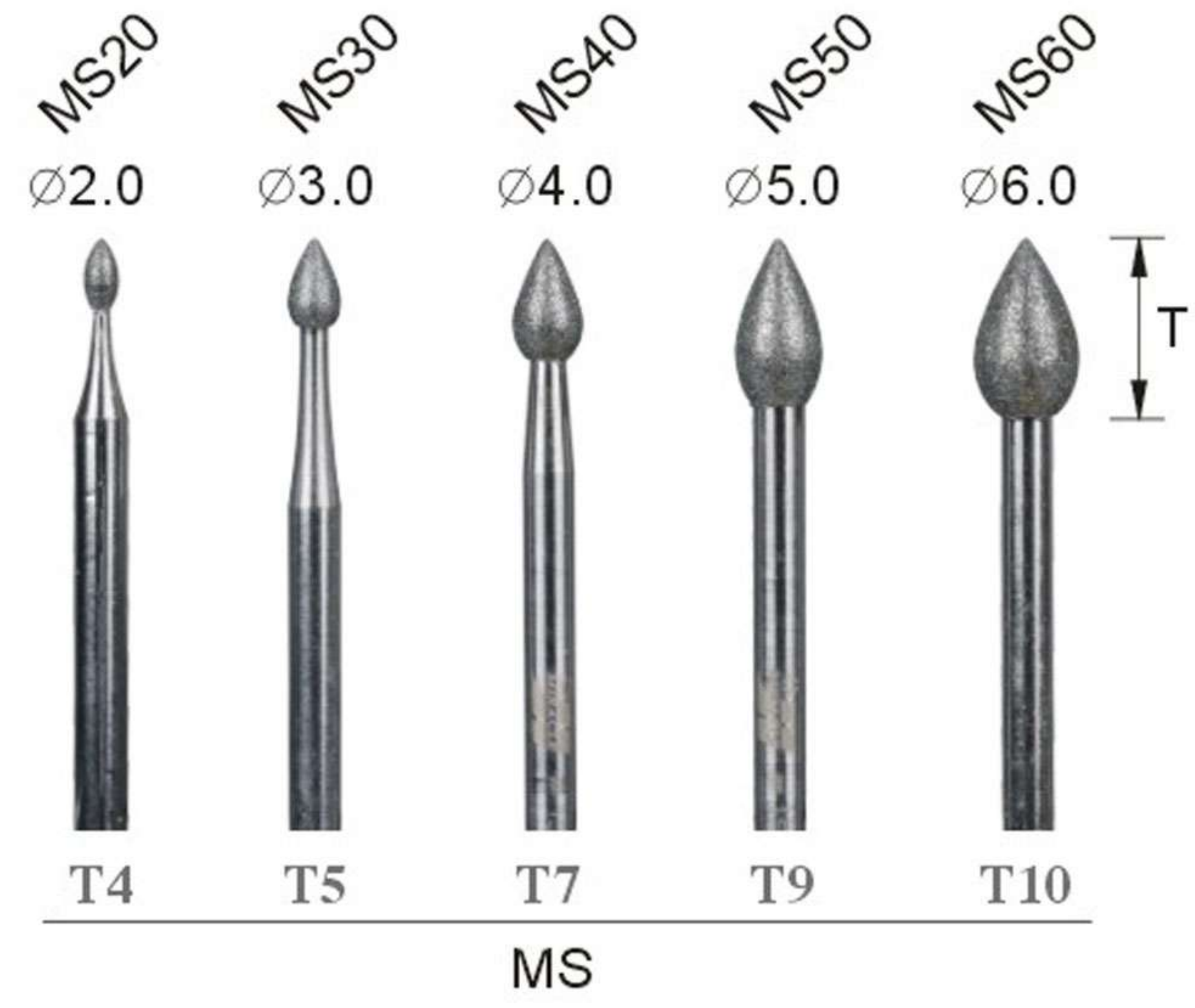
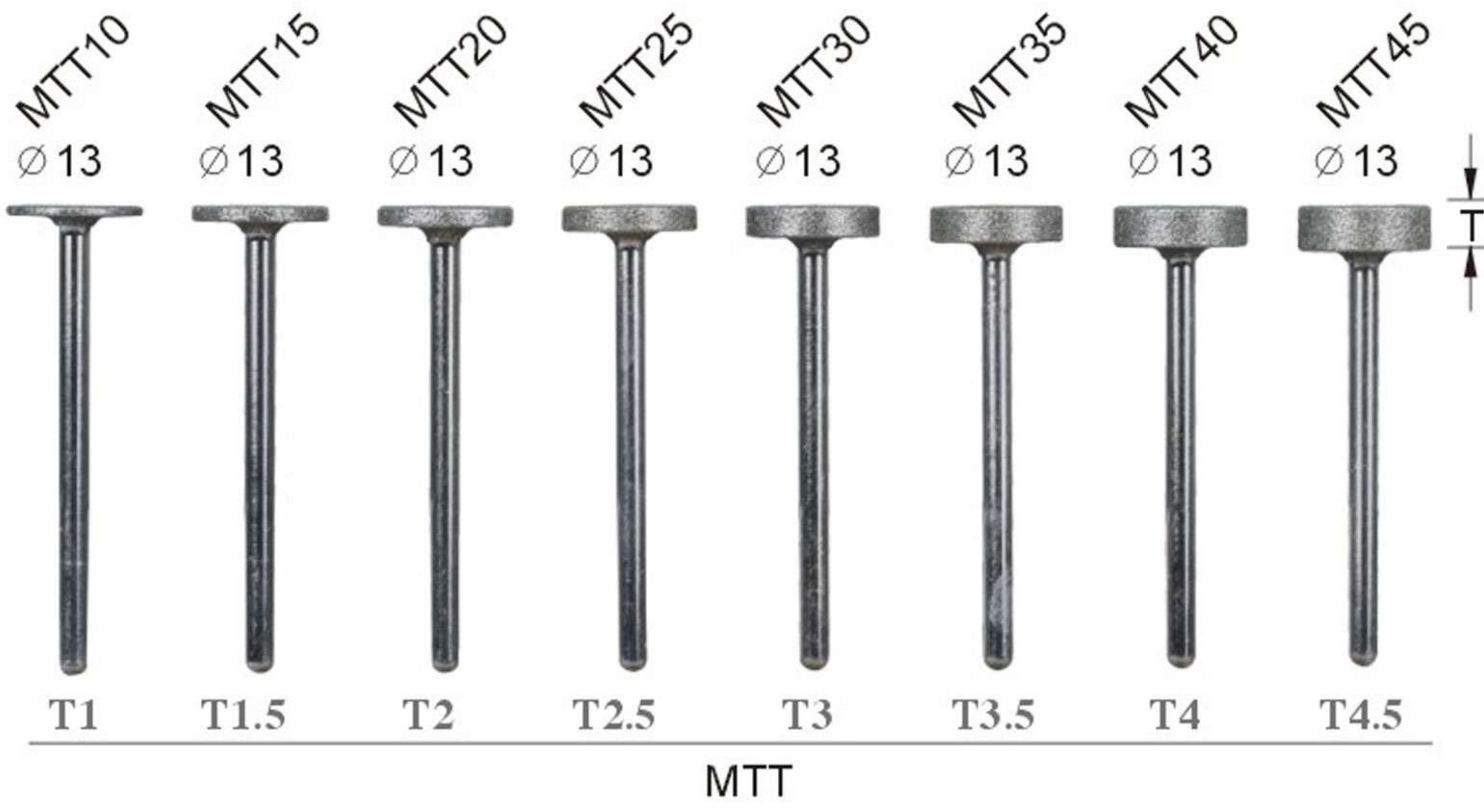
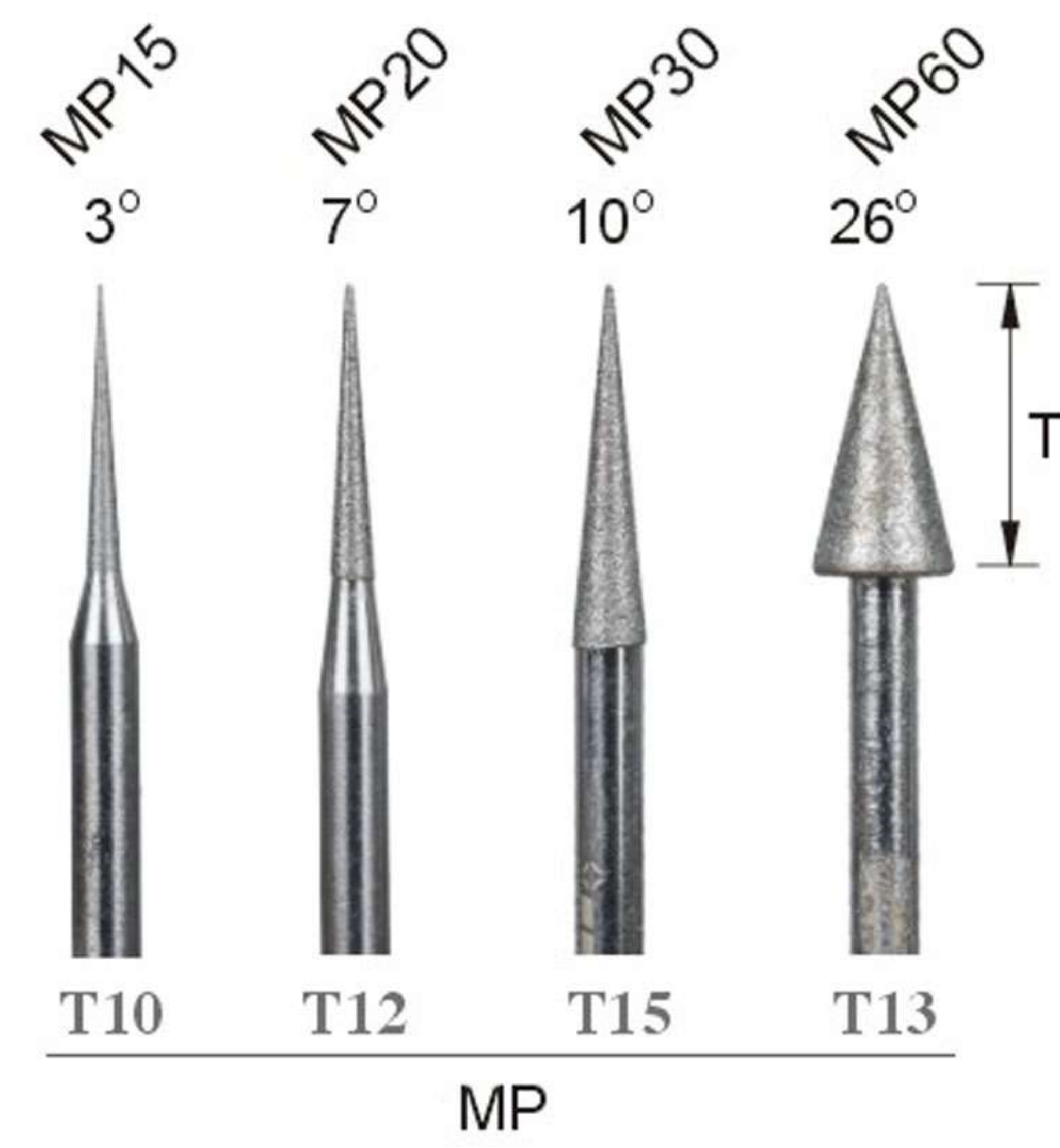
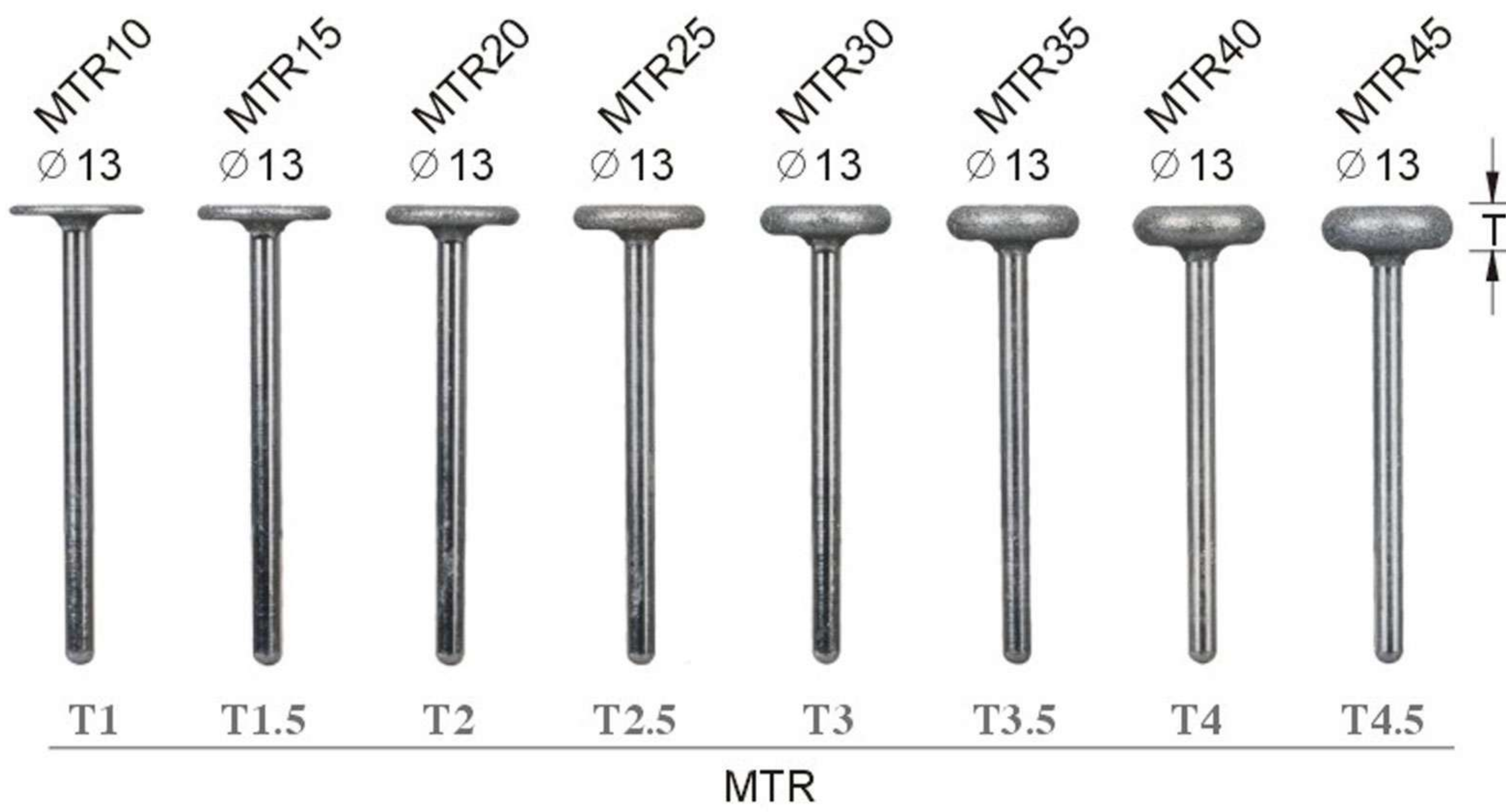
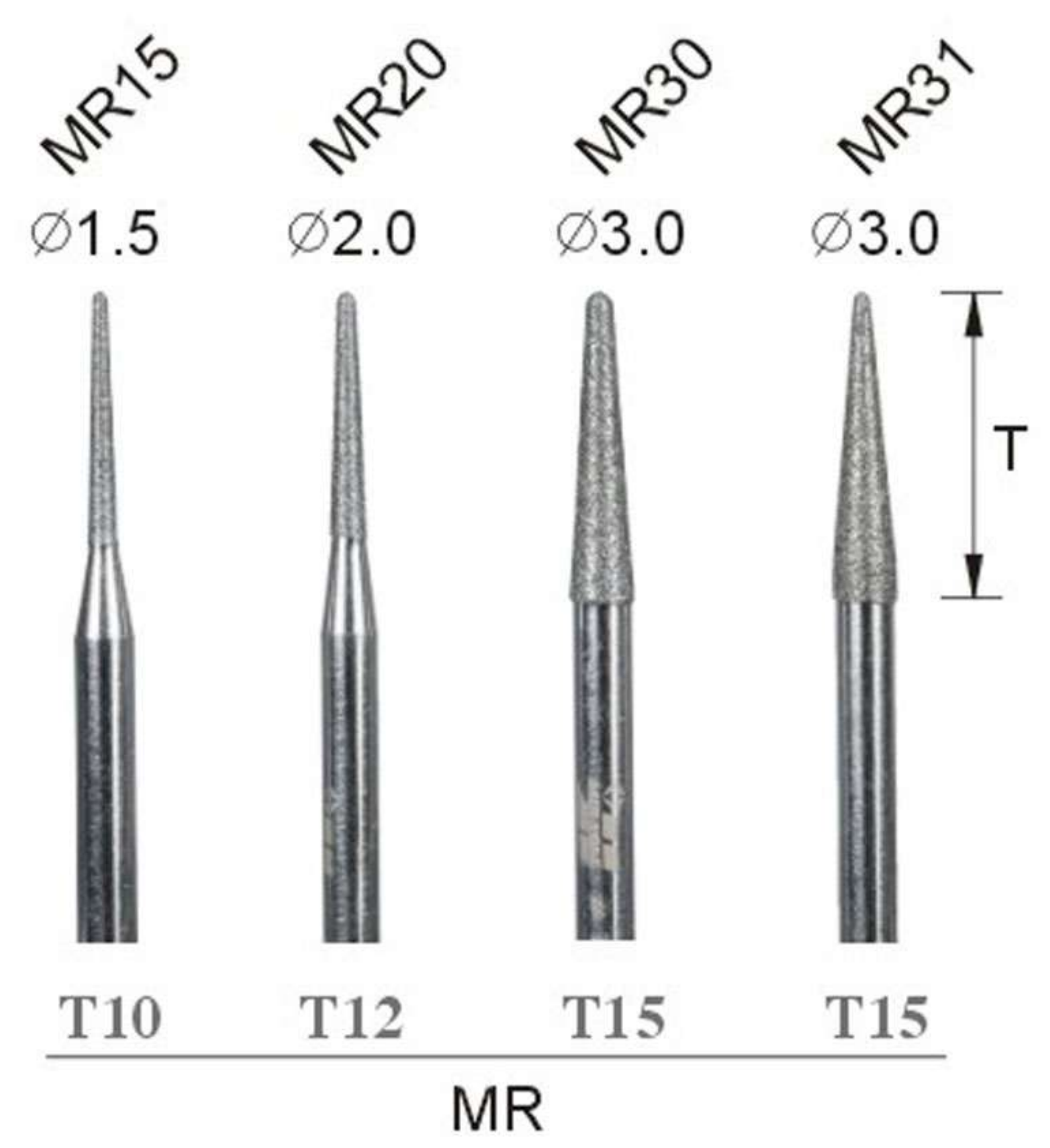
**蛋形
Egg Type**

**火焰形
Match Type**

**T 平形
Flat Type**

**尖形
Needle End Type**

**TR形
Round T Type**

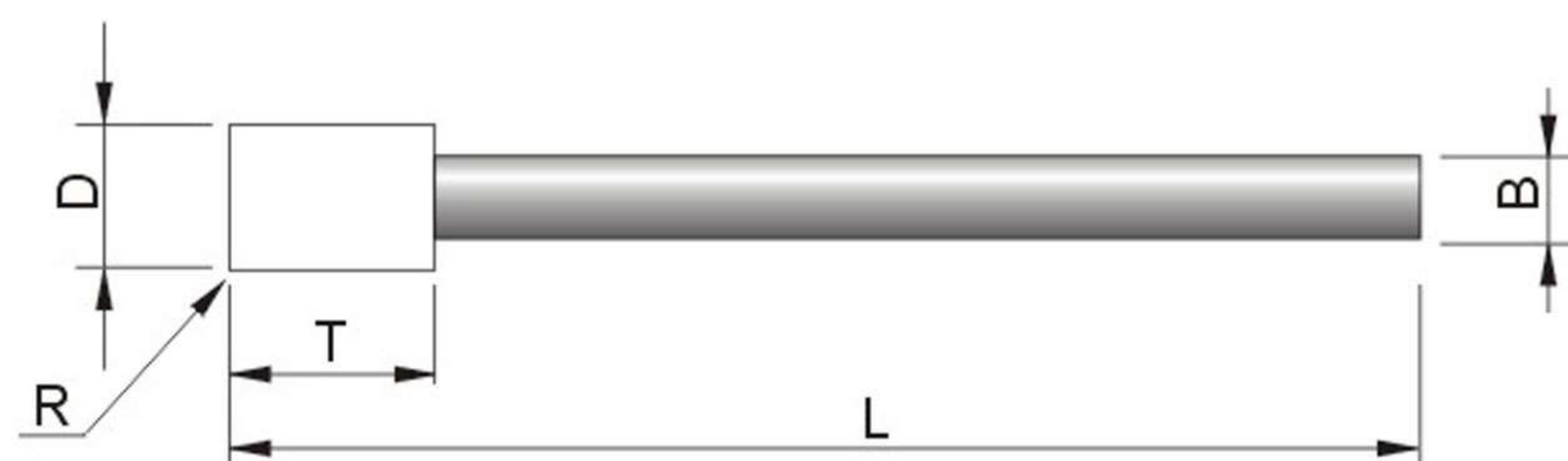
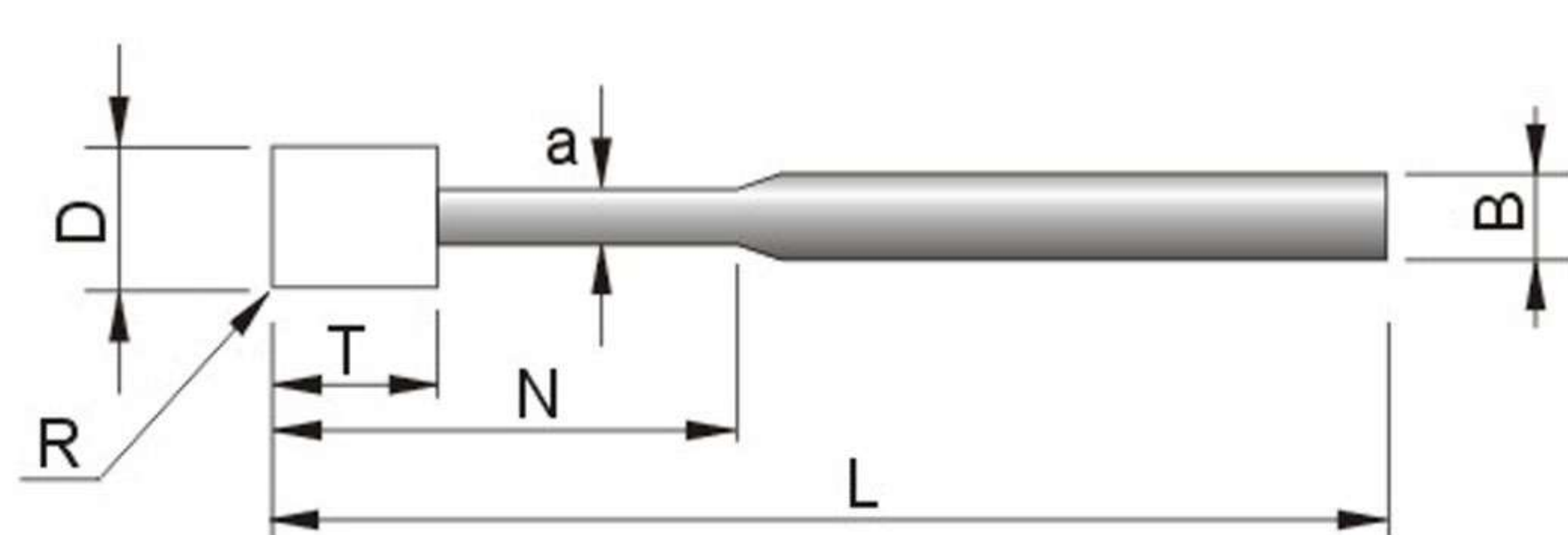
**錐形
Awl Type**

鑽石工具系列 Diamond File Series

MM

鑽石及氮化硼(CBN)內孔研磨輪 柄徑3mm

Diamond & CBN Mandrels(3mm Shank)



訂購編號 Order No.		外徑 D	厚度 T	N	全長 L	B	#100	#140	#200	#325	#400
鑽石 DIA	氮化硼 CBN										
MMD-3003	MMB-3003	0.3	2	3	35	3	X	X	X	X	○
MMD-3004	MMB-3004	0.4	2	3.5	35	3	X	X	X	X	○
MMD-3005	MMB-3005	0.5	2	3.5	35	3	X	X	X	○	○
MMD-3006	MMB-3006	0.6	2	6	35	3	X	X	○	○	○
MMD-3007	MMB-3007	0.7	2	7	35	3	X	X	○	○	○
MMD-3008	MMB-3008	0.8	3	7	35	3	X	○	○	○	○
MMD-3009	MMB-3009	0.9	3	7	35	3	X	○	○	○	○
MMD-3010	MMB-3010	1.0	3	7	45	3	X	○	○	○	○
MMD-3011	MMB-3011	1.1	3	7	45	3	X	○	○	○	○
MMD-3012	MMB-3012	1.2	3	12	45	3	X	○	○	○	○
MMD-3013	MMB-3013	1.3	3	12	45	3	X	○	○	○	○
MMD-3014	MMB-3014	1.4	3	12	45	3	○	○	○	○	○
MMD-3015	MMB-3015	1.5	3	13	45	3	○	○	○	○	○
MMD-3016	MMB-3016	1.6	4	13	45	3	○	○	○	○	○
MMD-3017	MMB-3017	1.7	4	13	45	3	X	○	○	○	○
MMD-3018	MMB-3018	1.8	4	13	45	3	○	○	○	○	○
MMD-3019	MMB-3019	1.9	4	13	45	3	○	○	○	○	○
MMD-3020	MMB-3020	2.0	4	13	45	3	○	○	○	○	○
MMD-3920	MMB-3920	2.0	5	20	45	3	○	○	○	○	○
MMD-3021	MMB-3021	2.1	4	13	45	3	○	○	○	○	○
MMD-3022	MMB-3022	2.2	4	13	45	3	○	○	○	○	○
MMD-3023	MMB-3023	2.3	4	13	45	3	○	○	○	○	○
MMD-3024	MMB-3024	2.4	4	13	45	3	○	○	○	○	○
MMD-3025	MMB-3025	2.5	4	13	45	3	○	○	○	○	○
MMD-3925	MMB-3925	2.5	5	25	45	3	○	○	○	○	○
MMD-3026	MMB-3026	2.6	4	13	45	3	○	○	○	○	○
MMD-3027	MMB-3027	2.7	4	13	45	3	○	○	○	○	○
MMD-3028	MMB-3028	2.8	4	13	45	3	○	○	○	○	○
MMD-3029	MMB-3029	2.9	4	13	45	3	○	○	○	○	○
MMD-3030	MMB-3030	3.0	5	13	45	3	○	○	○	○	○
MMD-3930	MMB-3930	3.0	5	25	45	3	○	○	○	○	○
MMD-3035	MMB-3035	3.5	5		45	3	○	○	○	○	○
MMD-3040	MMB-3040	4.0	5		45	3	○	○	○	○	○
MMD-3045	MMB-3045	4.5	5		45	3	○	○	○	○	○
MMD-3050	MMB-3050	5.0	8		45	3	○	○	○	○	○
MMD-3060	MMB-3060	6.0	8		45	3	○	○	○	○	○

訂購範例 Order Ex MMD 3010 140
 型號 尺寸 粒度
 Model No. Size Grit

鑽石工具系列

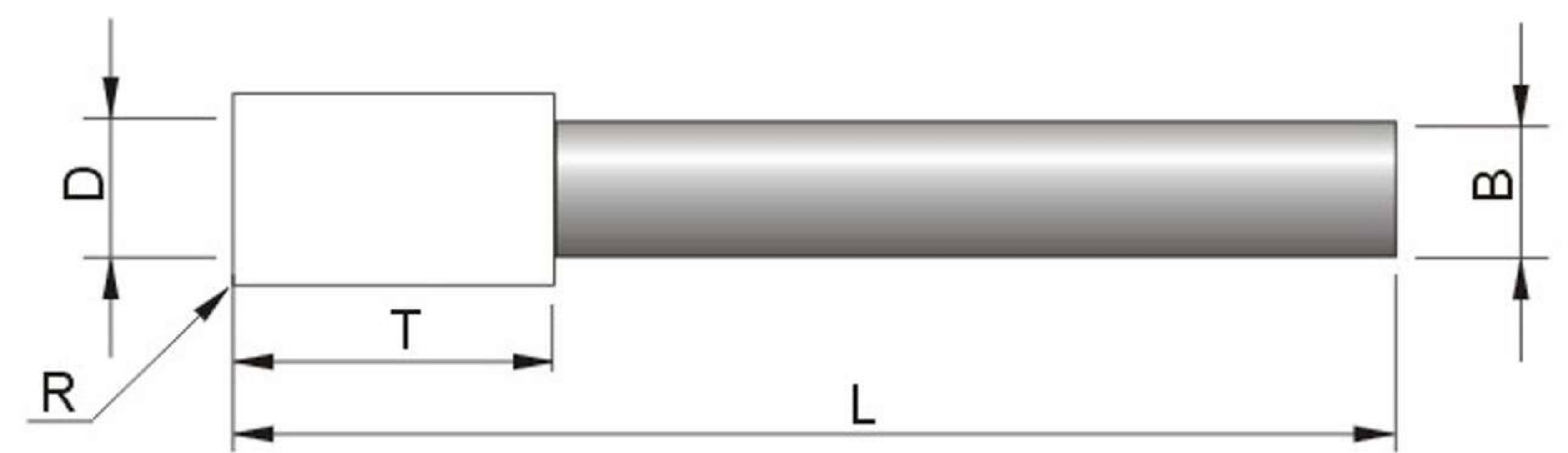
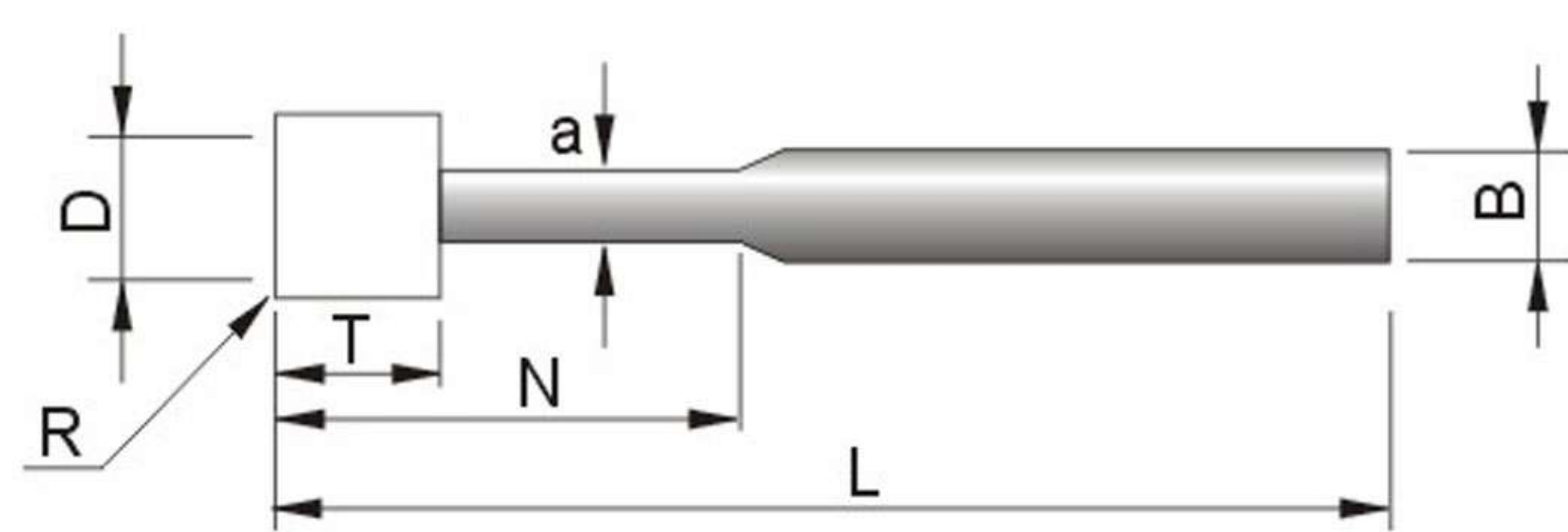

訂購編號 Order No.		外徑 D	厚度 T	N	全長 L	B	#100	#140	#200	#325	#400
鑽石 DIA	氮化硼 CBN										
MMD-6020	MMB-6020	2.0	10	30	80	6	○	○	○	○	○
MMD-6025	MMB-6025	2.5	10	30	80	6	○	○	○	○	○
MMD-6030	MMB-6030	3.0	10	30	80	6	○	○	○	○	○
MMD-6035	MMB-6035	3.5	10	30	80	6	○	○	○	○	○
MMD-6040	MMB-6040	4.0	10	30	80	6	○	○	○	○	○
MMD-6045	MMB-6045	4.5	10	30	80	6	○	○	○	○	○
MMD-6050	MMB-6050	5.0	10	30	80	6	○	○	○	○	○
MMD-6055	MMB-6055	5.5	10	30	80	6	○	○	○	○	○
MMD-6060	MMB-6060	6.0	10	35	80	6	○	○	○	○	○
MMD-6065	MMB-6065	6.5	10		80	6	○	○	○	○	○
MMD-6070	MMB-6070	7.0	10		80	6	○	○	○	○	○
MMD-6075	MMB-6075	7.5	10		80	6	○	○	○	○	○
MMD-6080	MMB-6080	8.0	10		80	6	○	○	○	○	○
MMD-6085	MMB-6085	8.5	10		80	6	○	○	○	○	○
MMD-6090	MMB-6090	9.0	10		80	6	○	○	○	○	○
MMD-6100	MMB-6100	10.0	10		80	6	○	○	○	○	○
MMD-6110	MMB-6110	11.0	10		80	6	○	○	○	○	○
MMD-6120	MMB-6120	12.0	10		80	6	○	○	○	○	○
MMD-6130	MMB-6130	13.0	10		80	6	○	○	○	○	○
MMD-6140	MMB-6140	14.0	10		80	6	○	○	○	○	○
MMD-6150	MMB-6150	15.0	10		80	6	○	○	○	○	○
MMD-6160	MMB-6160	16.0	10		80	6	○	○	○	○	○
MMD-6170	MMB-6170	17.0	10		80	6	○	○	○	○	○
MMD-6180	MMB-6180	18.0	10		80	6	○	○	○	○	○
MMD-6200	MMB-6200	20.0	10		80	6	○	○	○	○	○
MMD-6210	MMB-6210	21.0	10		80	6	○	○	○	○	○
MMD-6220	MMB-6220	22.0	10		80	6	○	○	○	○	○
MMD-6250	MMB-6250	25.0	10		80	6	○	○	○	○	○

訂購範例 Order Ex MMD 6020 140
 型號 尺寸 粒度
 Model No. Size Grit

鎢鋼滾磨刀 Solid Carbide

SA圓筒型

Cylinder Shape

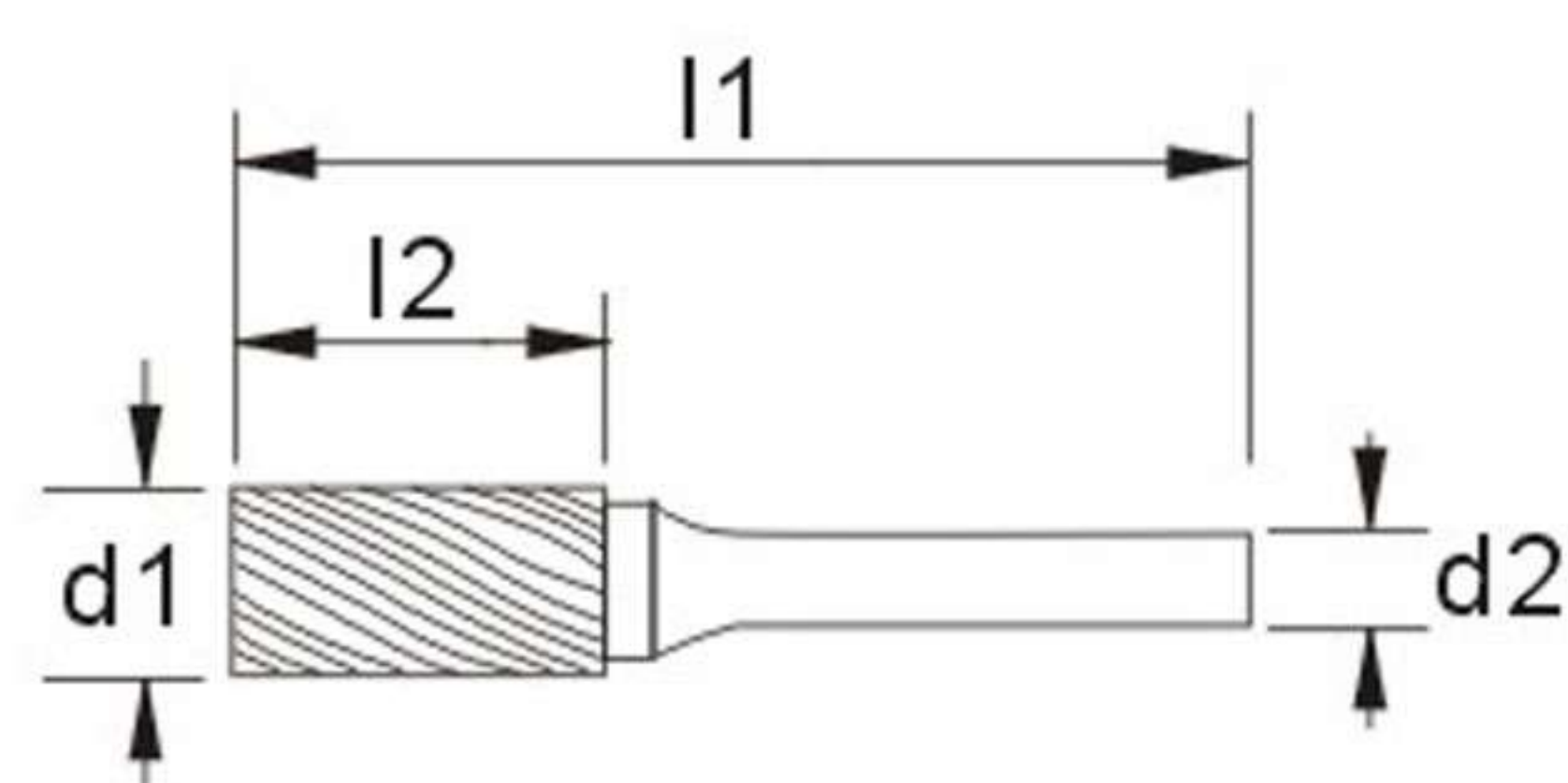

訂購編號 Order No.	Cutting Dia	Shank Dia	Length of Cut	Overall Length
	d1 mm	d2 mm	l2 mm	l1 mm
SA-41M	1.5	3	6	38
SA-42M	2.5	3	11	38
SA-43M	3	3	14	38
SA-51M	6	3	12	50
SA-51M/EC	6	3	12	50
SA-52M	4	3	12.7	38
SA-53M	5	3	12.7	38
SA-13M	4	6	16	50
SA-14M	5	6	16	50
SA-1M	6	6	16	50
SA-2M	8	6	19	63
SA-3M	9.5	6	19	63
SA-5M	12.7	6	25	69
SA-6M	16	6	25	69
SA-7M	19	6	25	69
SA-9M	25	6	25	69

SB圓筒型 / EC

Cylinder Shape / EC

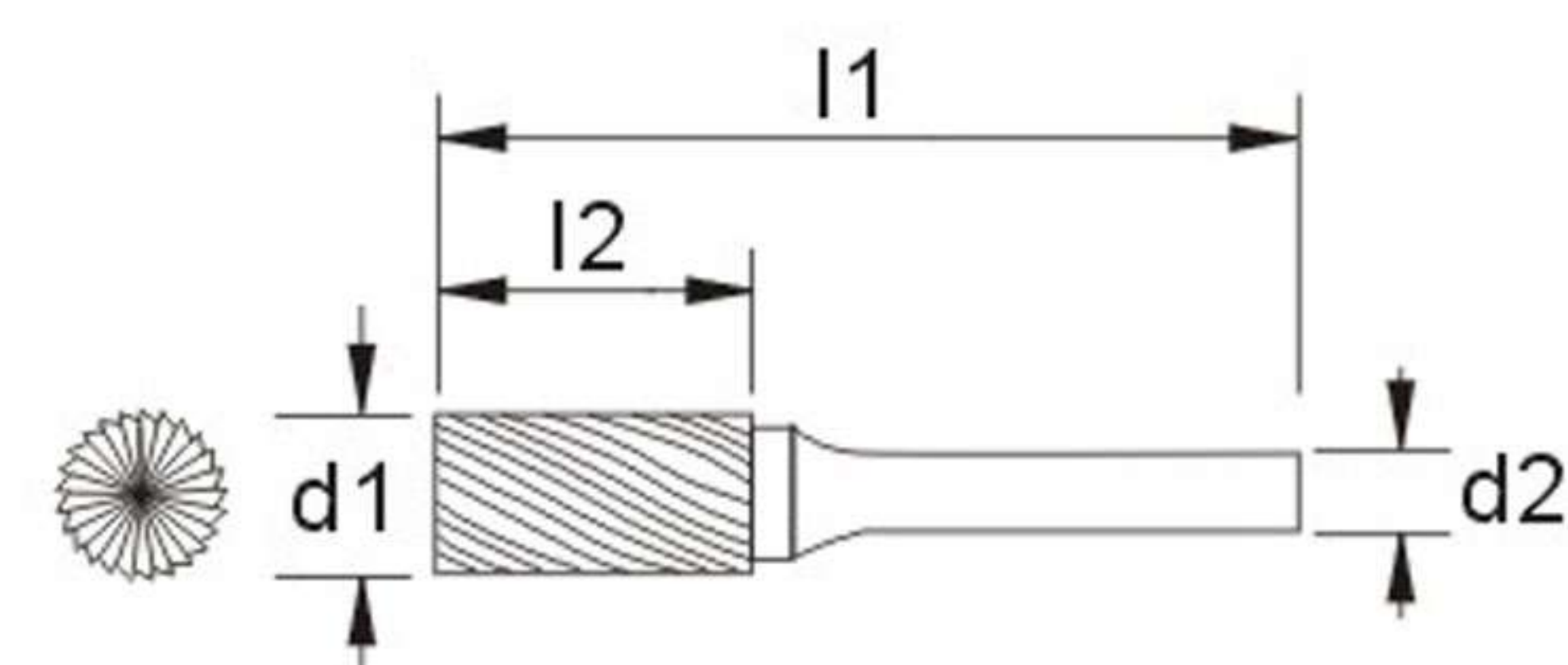

訂購編號 Order No.	Cutting Dia	Shank Dia	Length of Cut	Overall Length
	d1 mm	d2 mm	l2 mm	l1 mm
SB-43M	3	3	14	38
SB-51M	6.3	3	4.7	43
SB-13M	4	6	16	50
SB-14M	5	6	16	50
SB-1M	6	6	16	50
SB-2M	8	6	19	63
SB-3M	9.5	6	19	63
SB-5M	12.7	6	25	69
SB-6M	16	6	25	69
SB-7M	19	6	25	69
SB-9M	25	6	25	69

SC圓筒R型

Cylinder Shape Radius End

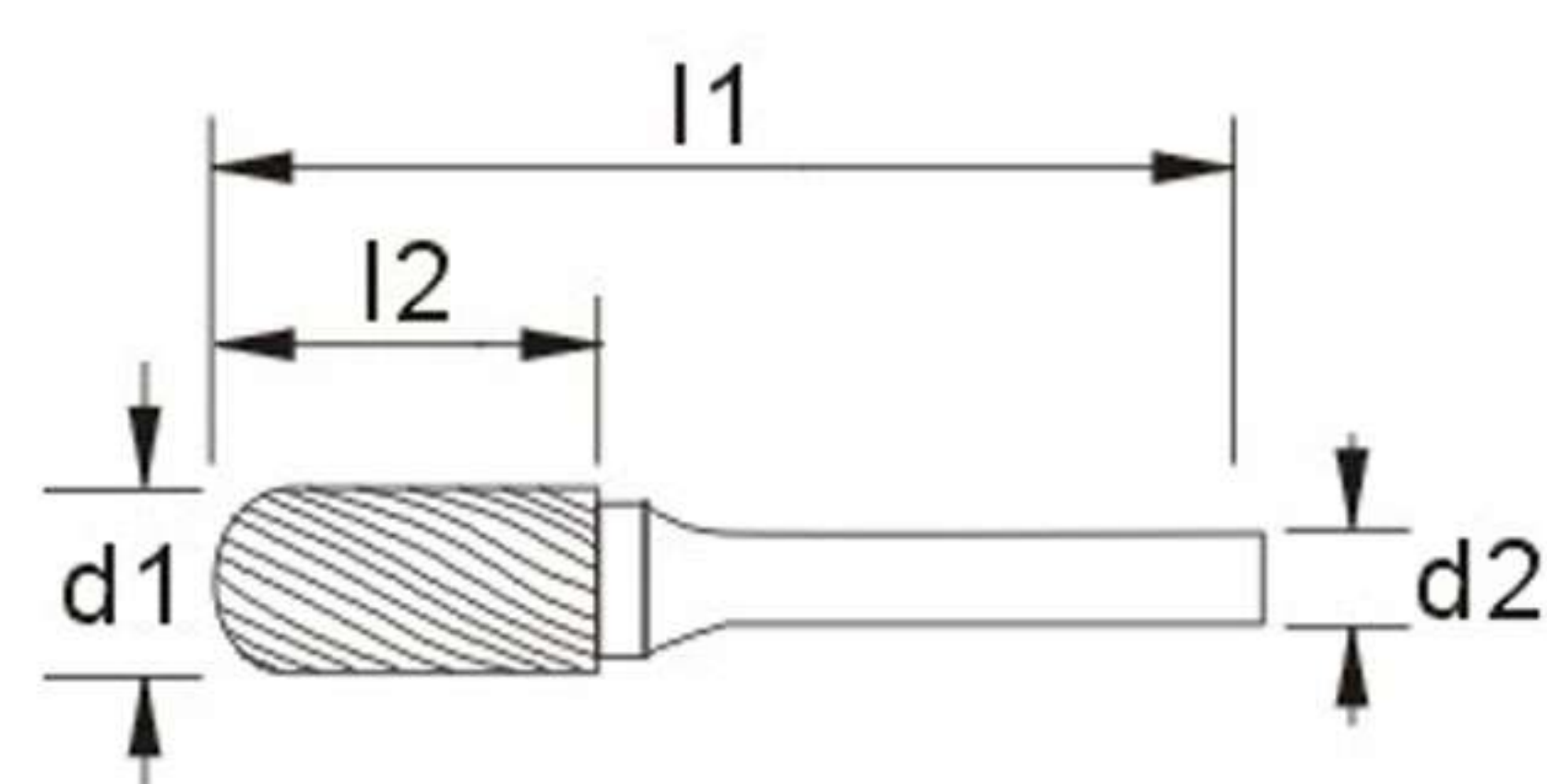

訂購編號 Order No.	Cutting Dia	Shank Dia	Length of Cut	Overall Length
	d1 mm	d2 mm	l2 mm	l1 mm
SC-41M	2.5	3	11	38
SC-42M	3	3	14	38
SC-51M	6.3	3	12.7	50
SC-52M	4	3	12.7	38
SC-53M	5	3	12.7	38
SC-13M	4	6	16	50
SC-14M	5	6	16	50
SC-1M	6	6	16	50
SC-2M	8	6	19	63
SC-3M	9.5	6	19	63
SC-5M	12.7	6	25	69
SC-6M	16	6	25	69
SC-7M	19	6	25	69
SC-9M	25	6	25	69

*d:交叉紋(標準品)

*s:單斜紋(訂制品)

*nf:鋁質及銅質用(僅提供6mm柄)

SD球型

Ball Shape

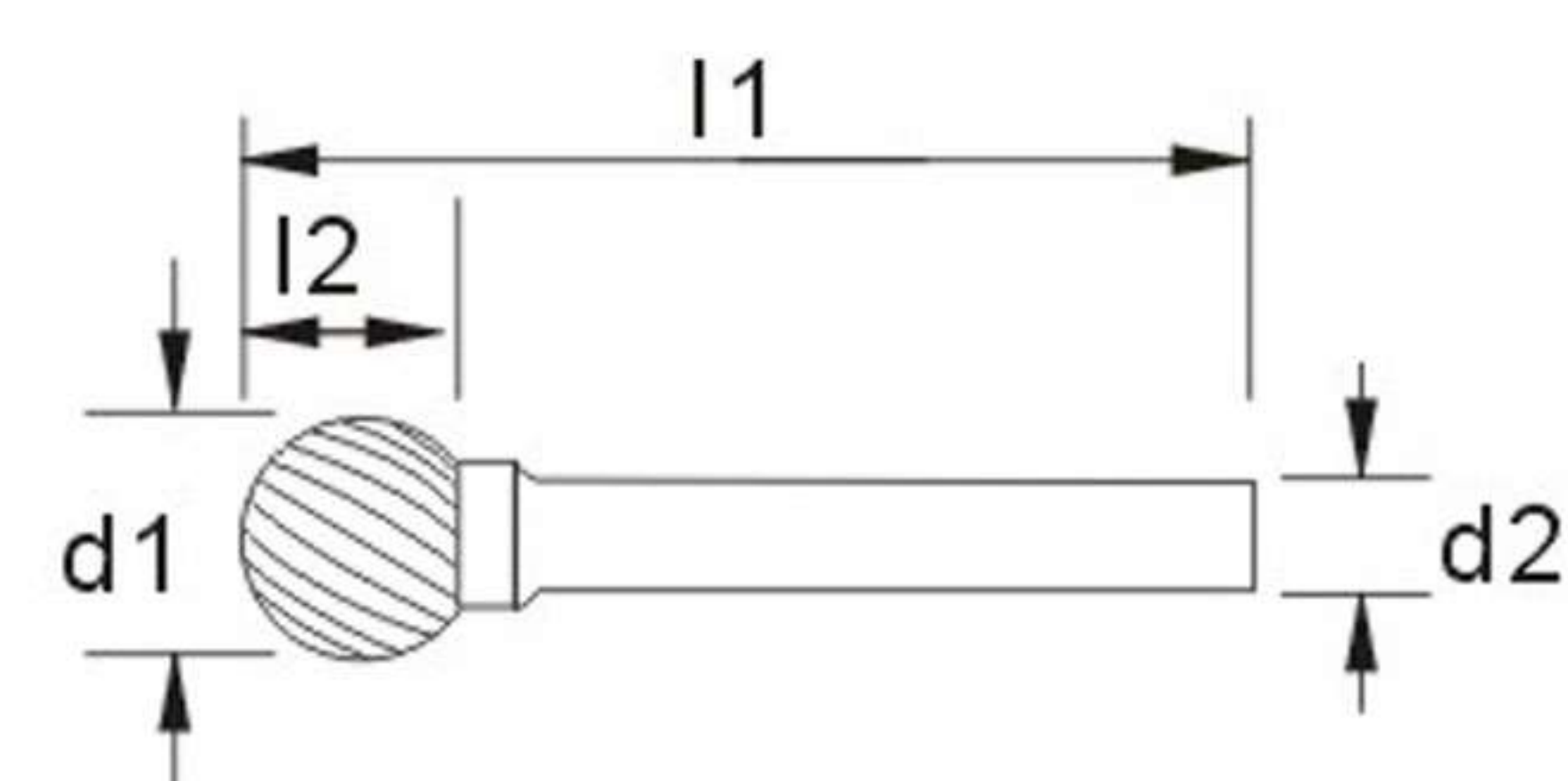

訂購編號 Order No.	Cutting Dia	Shank Dia	Length of Cut	Overall Length
	d1 mm	d2 mm	l2 mm	l1 mm
SD-41M	2.5	3	2.3	38
SD-42M	3	3	2.8	38
SD-51M	6.3	3	5	44
SD-52M	4	3	3.4	38
SD-53M	5	3	4.7	38
SD-13M	3	6	2.8	50
SD-14M	5	6	4	50
SD-1M	6	6	5	50
SD-2M	8	6	6.4	50
SD-3M	9.5	6	8	52
SD-5M	12.7	6	11	55
SD-6M	16	6	14	58
SD-7M	19	6	16	62
SD-9M	25	6	21	72

*d:double(standard)

*s:single cut(custom made)

*nf:nonferrous(only available for 6mm shank)

SE蛋型
Oval Shape

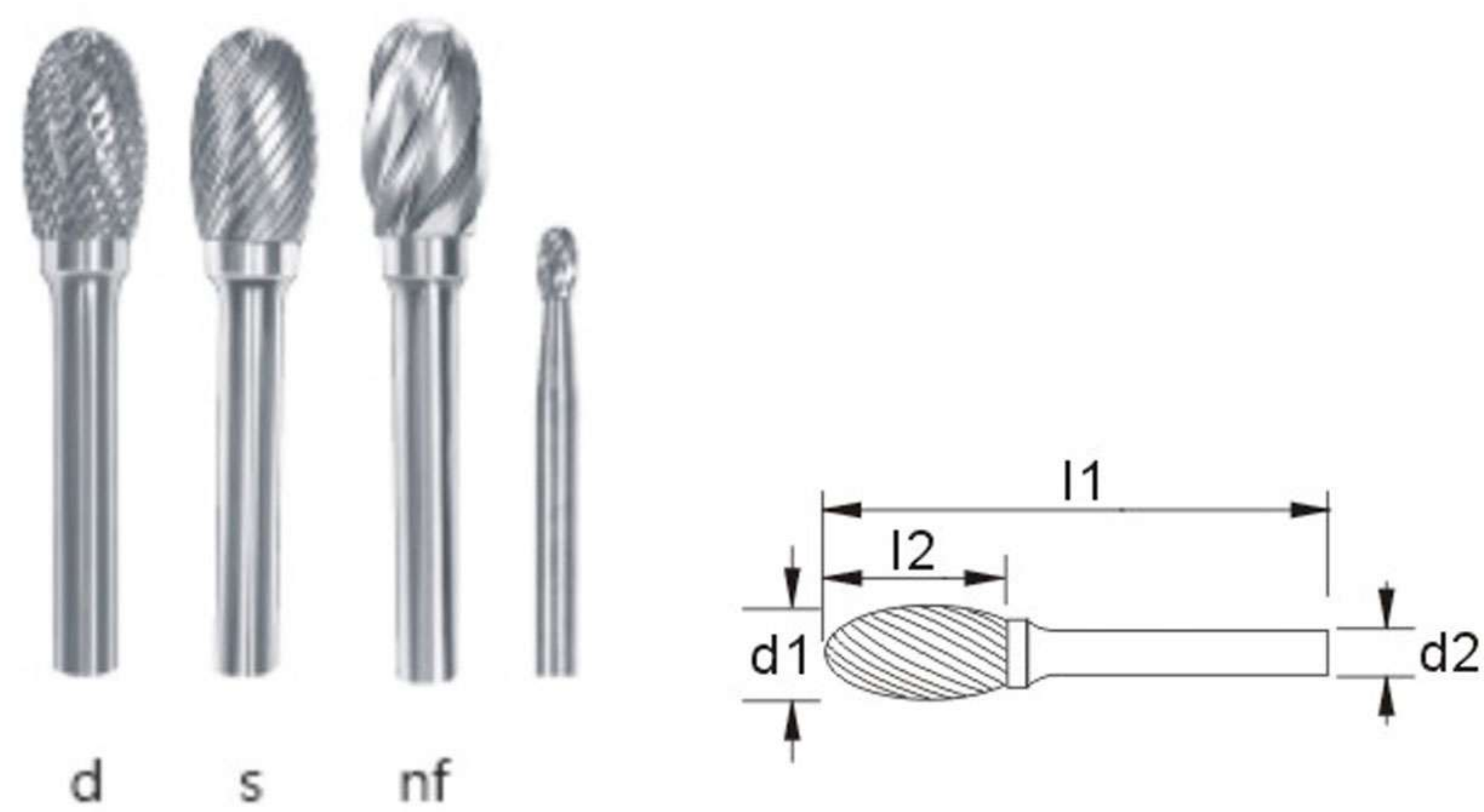

訂購編號 Order No.	Cutting Dia	Shank Dia	Length of Cut	Overall Length
	d1 mm	d2 mm	l2 mm	l1 mm
SE-41M	3	3	5.5	38
SE-51M	6.3	3	9.5	47
SE-53M	5	3	7.1	38
SE-1M	6	6	9.5	50
SE-3M	9.5	6	16	60
SE-5M	12.7	6	22	66
SE-6M	16	6	25	69
SE-7M	19	6	25	69

SF桃型
Tree Shape

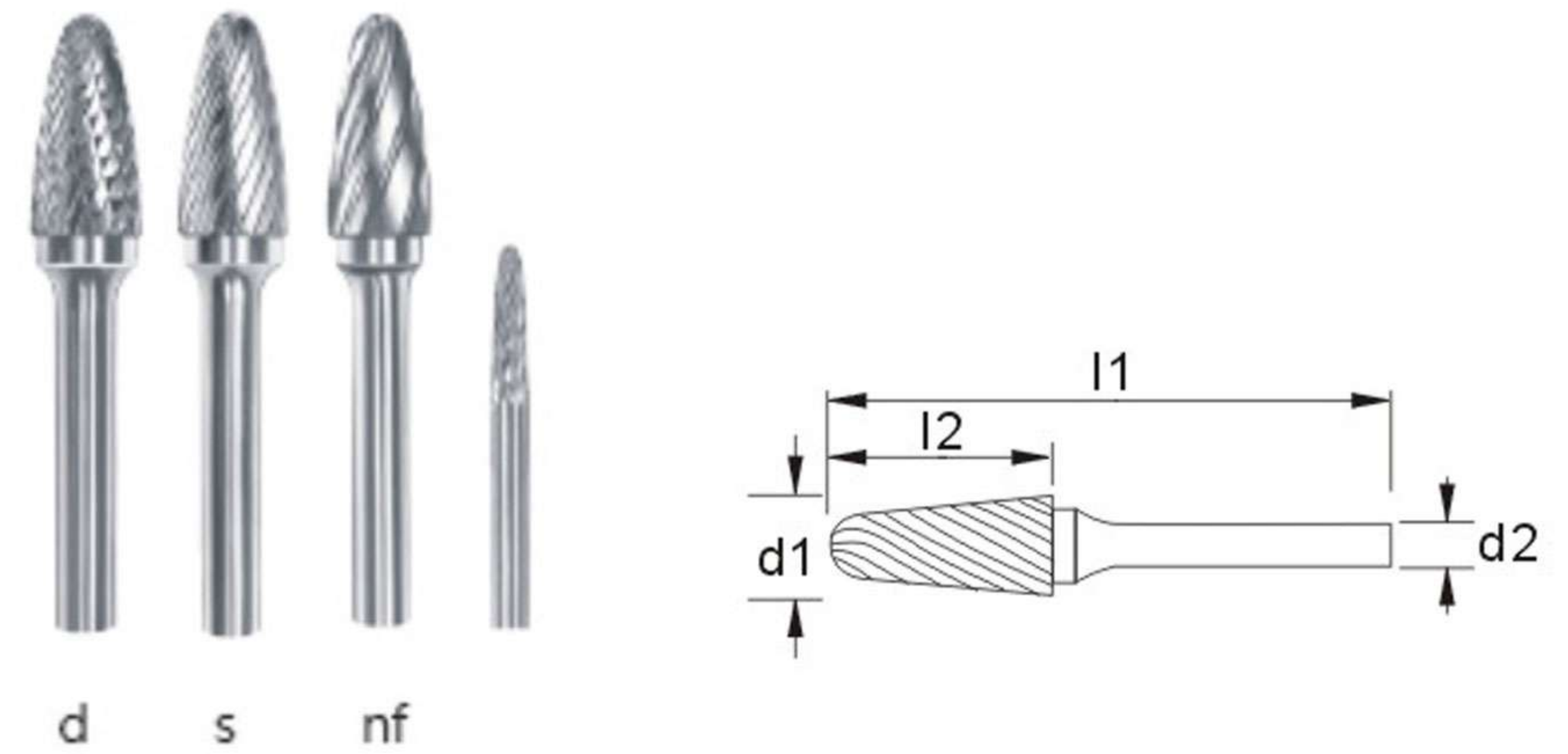

訂購編號 Order No.	Cutting Dia	Shank Dia	Length of Cut	Overall Length
	d1 mm	d2 mm	l2 mm	l1 mm
SF-41M	3	3	6	38
SF-42M	3	3	12.7	38
SF-51M	6.3	3	12.7	56
SF-53M	5	3	12.7	38
SF-14M	19	6	32	76
SF-15M	19	6	38	82
SF-1M	6	6	16	50
SF-3M	9.5	6	19	63
SF-5M	12.7	6	25	69
SF-6M	16	6	25	69
SF-7M	19	6	25	69

SG桃尖型
Tree Shape Pointed End

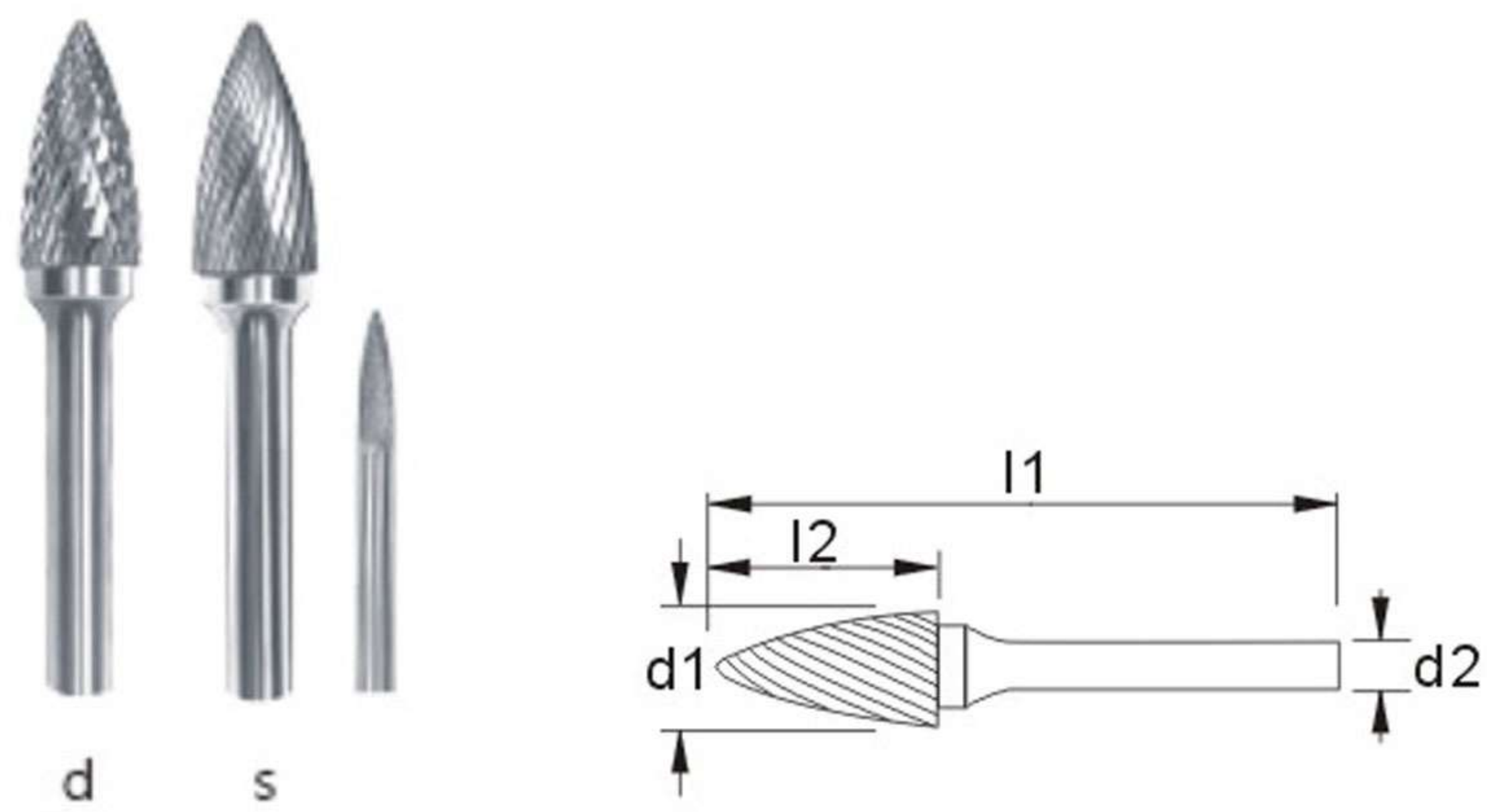

訂購編號 Order No.	Cutting Dia	Shank Dia	Length of Cut	Overall Length
	d1 mm	d2 mm	l2 mm	l1 mm
SG-41M	3	3	6	38
SG-43M	3	3	9.5	38
SG-44M	3	3	12.7	38
SG-51M	6.3	3	12.7	50
SG-53M	5	3	12.7	38
SG-1M	6	6	16	50
SG-2M	8	6	19	63
SG-3M	9.5	6	19	63
SG-5M	7	6	25	69
SG-6M	16	6	25	69
SG-7M	19	6	25	69
SC-15M	19	6	38	82

*d:交叉紋(標準品)
*s:單斜紋(訂制品)
*nf:鋁質及銅質用(僅提供6mm柄)

SH火焰型
Flame Shape

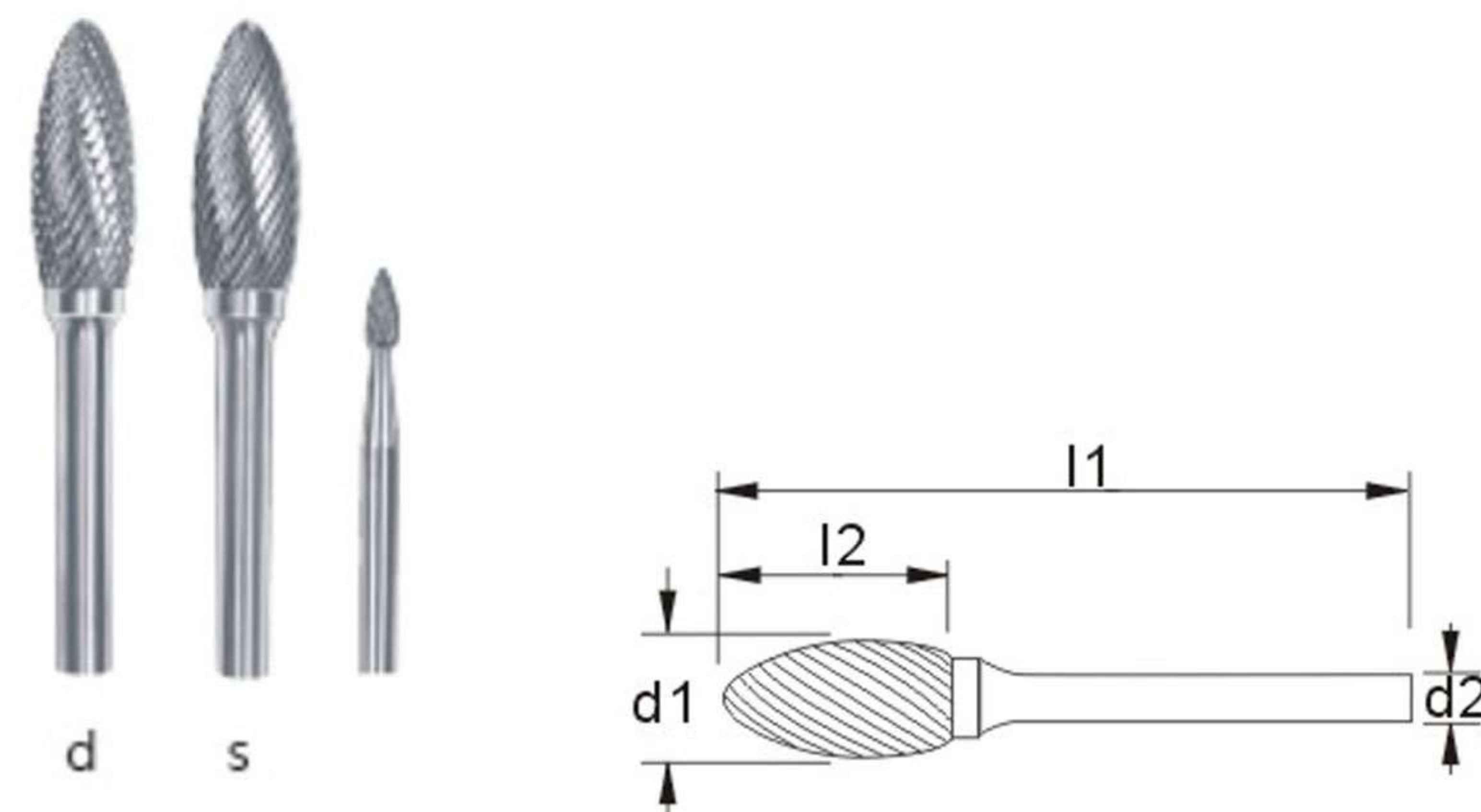

訂購編號 Order No.	Cutting Dia	Shank Dia	Length of Cut	Overall Length
	d1 mm	d2 mm	l2 mm	l1 mm
SH-41M	3	3	6.3	38
SH-53M	5	3	9.5	38
SH-1M	6	6	16	50
SH-2M	8	6	19	63
SH-5M	12.7	6	32	76
SH-6M	16	6	36	80
SH-7M	19	6	41	85

*d:double(standard)
*s:single cut(custom made)
*nf:nonferrous(only available for 6mm shank)

鎢鋼滾磨刀 Solid Carbide

SL錐R型

Taper Shape-Radius End

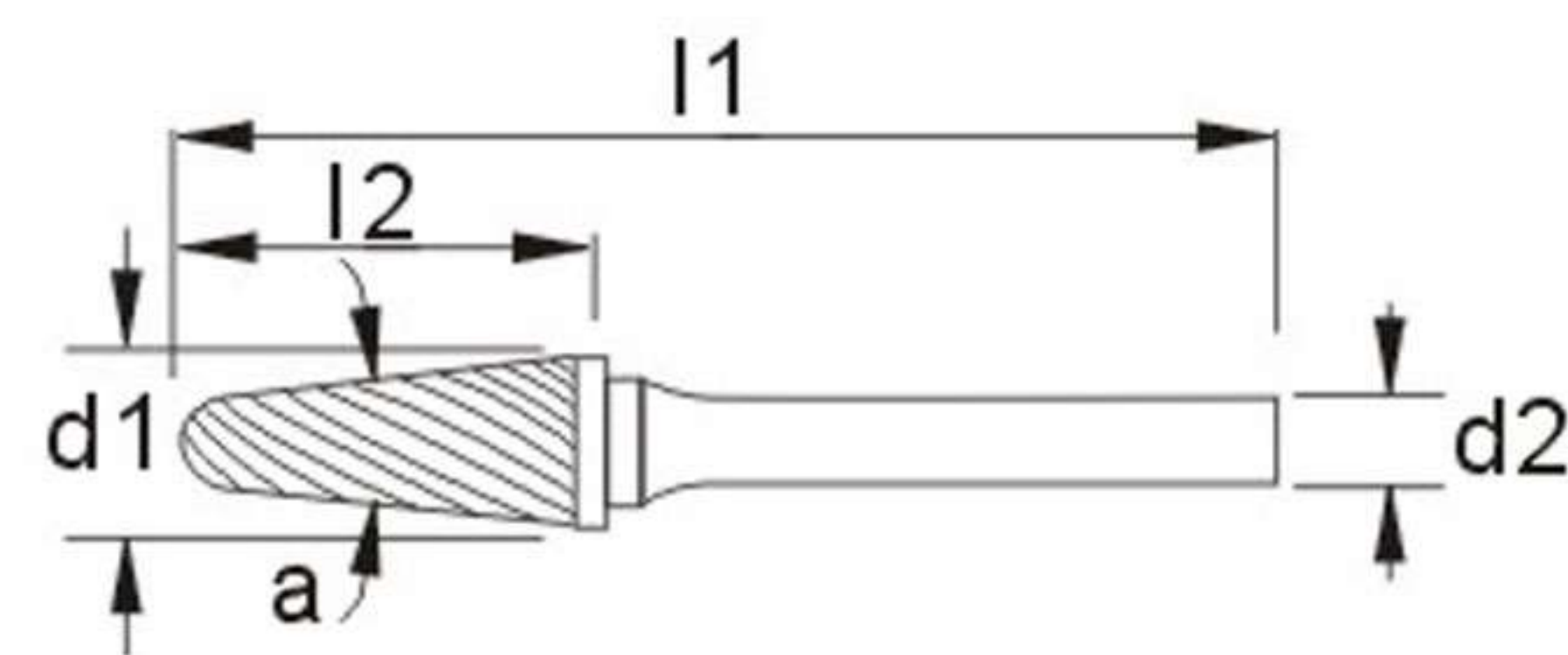

訂購編號 Order No.	Cutting Dia	Shank Dia	Length of Cut	Overall Length	Angle
	d1 mm	d2 mm	l2 mm	l1 mm	a
SL-41M	3	3	9.5	38	8°
SL-42M	3	3	12.7	38	8°
SL-53M	5	3	12.7	38	14°
SL-1M	6	6	16	50	14°
SL-2M	8	6	22	69	14°
SL-3M	9.5	6	27	74	14°
SL-4M	12.7	6	28	76	14°
SL-5M	16	6	30	77	14°
SL-7M	19	6	38	85	14°

SM圓錐型

Cone Shape

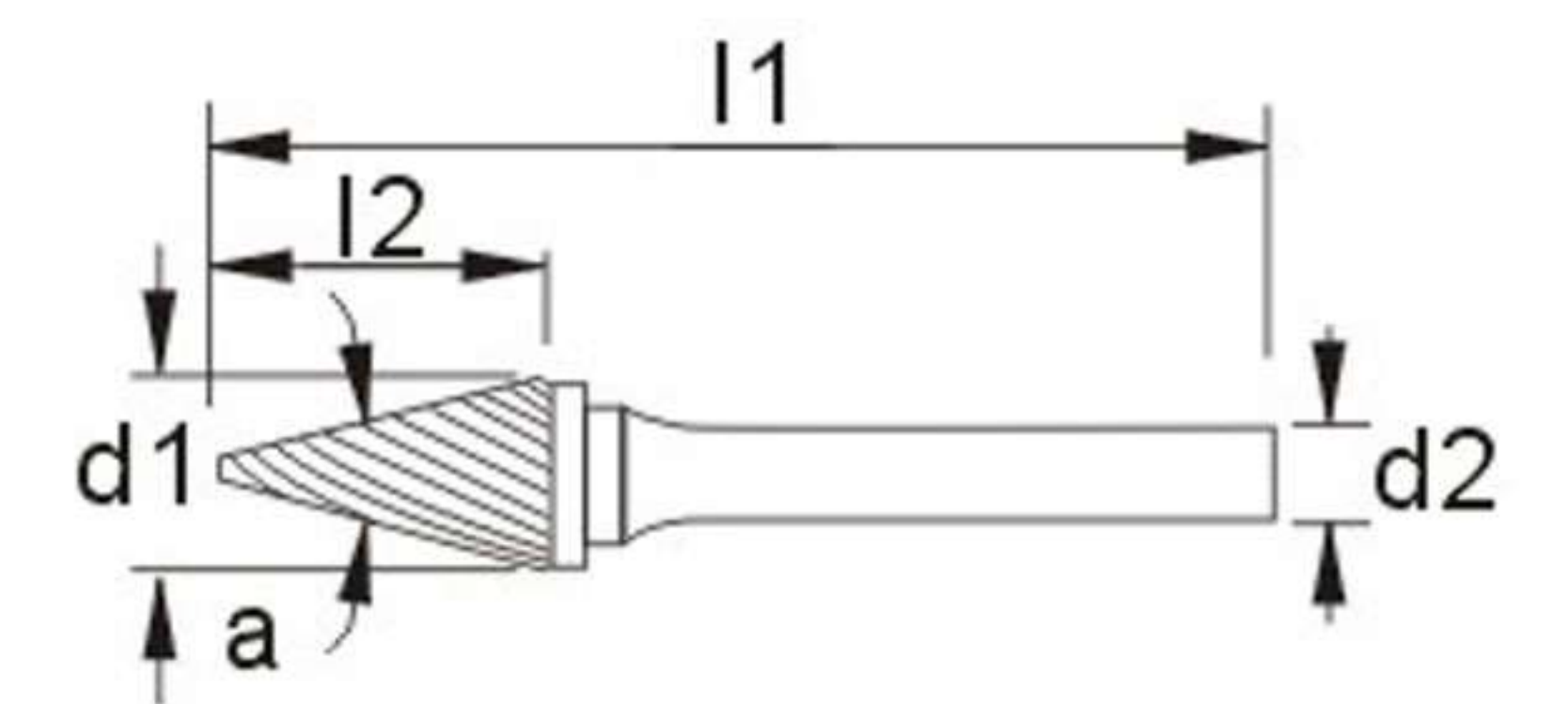

訂購編號 Order No.	Cutting Dia	Shank Dia	Length of Cut	Overall Length	Angle
	d1 mm	d2 mm	l2 mm	l1 mm	a
SM-41M	3	3	8.9	38	12°
SM-42M	3	3	11	38	14°
SM-43M	3	3	16	38	7°
SM-51M	6.3	3	12.7	53	22°
SM-53M	5	3	12.7	38	16°
SM-1M	6	6	12.7	50	22°
SM-2M	6	6	19	50	14°
SM-3M	6	6	25	50	10°
SM-4M	9.5	6	16	63	28°
SM-5M	12.7	6	22	69	28°
SM-6M	16	6	25	73	31°

SN皇冠型

Inverted Cone Shape

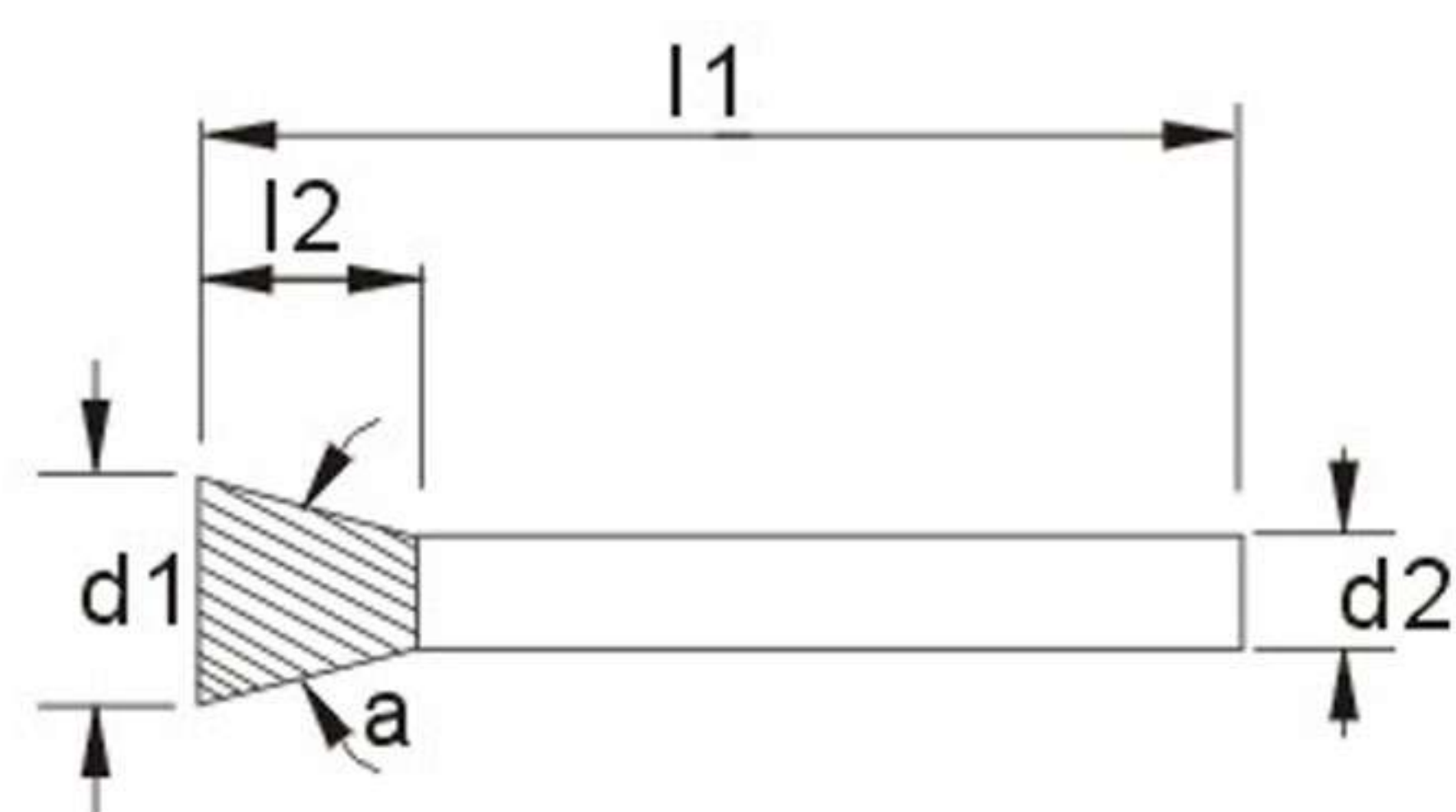

訂購編號 Order No.	Cutting Dia	Shank Dia	Length of Cut	Overall Length	Angle
	d1 mm	d2 mm	l2 mm	l1 mm	a
SN-41M	2.5	3	3	38	10°
SN-42M	3	3	4	38	10°
SN-51M	6.3	3	6	44	10°
SN-53M	5	3	6.3	38	10°
SN-1M	6	6	8	50	10°
SN-2M	9.5	6	9.5	53	13°
SN-4M	12.7	6	12.7	57	28°
SN-6M	16	6	19	63	18°
SN-7M	19	6	16	60	30°

*d:交叉紋(標準品)

*s:單斜紋(訂制品)

*nf:鋁質及銅質用(僅提供6mm柄)

*d:double(standard)

*s:single cut(custom made)

*nf:nonferrous(only available for 6mm shank)

DPS 鑽石油石 Diamond Polishing Stones

鑽石油石
Diamond Polishing Stones

鑽石油石主要使用于各種刀具研磨后之刃部修磨，延長刀具之壽命及提高加工物之表面光潔度。此外，亦適用於鎢鋼、陶瓷及硬化鋼料之表面研磨。

diamond Polishing Stone is considered as finish for cutting tools. It is used to refine a surface by removing scratch lines and other surface imperfections. Therefore prolong the tools life and smooth a surface finish. Also apply to lap the tungsten ceramics and hardened steels.

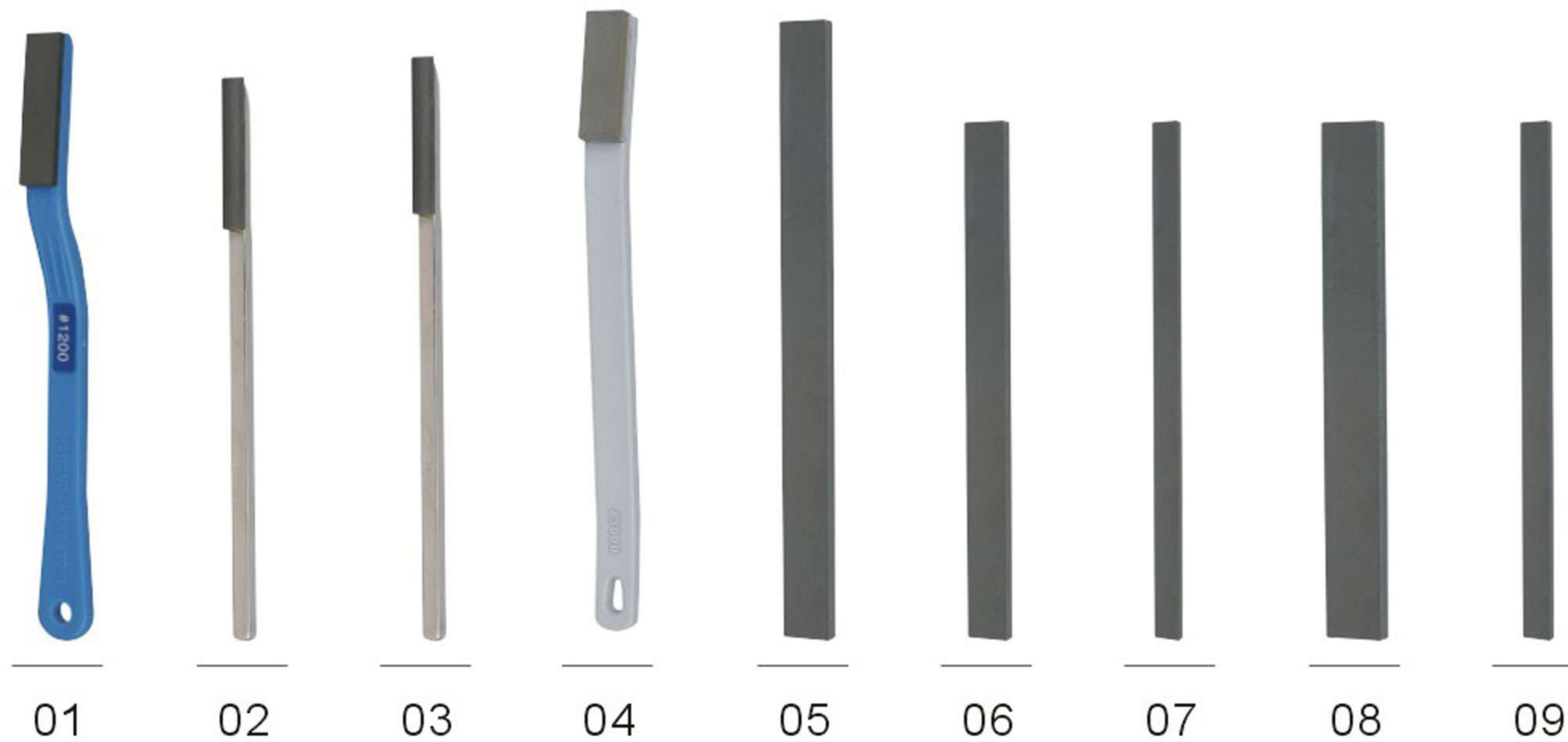

標準粒度(Grit Size):
#100, #200, #400, #600, #800, #1000, #1200, #1800, #2000, #3000, #5000,



訂購編號 Order No.	尺寸Wx(R)xXxW Dimensions	柄部材質 Shank Material
DPS-01-粒度(Grit)	10x2x40	塑膠柄PLASTIC SHANK
DPS-02-粒度(Grit)	5x2x40	鐵柄STEEL SHANK
DPS-03-粒度(Grit)	5x(2.5R)x4x40	鐵柄STEEL SHANK
DPS-04-粒度(Grit)	10x2x30	鋁柄ALUMINUM SHANK

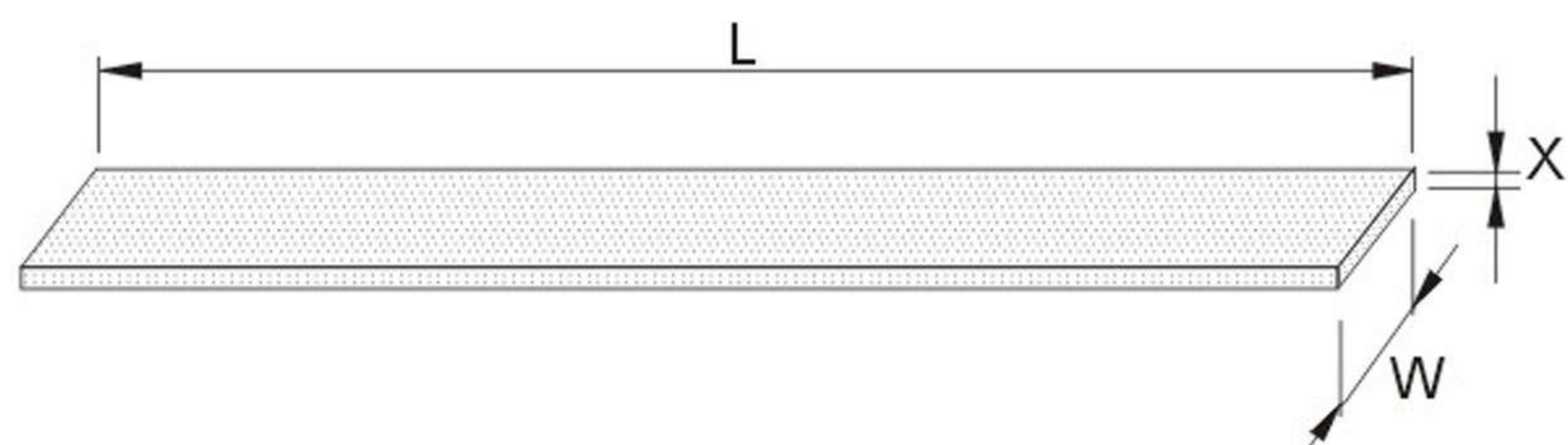

訂購編號 Order No.	尺寸Wx(R)xXxW Dimensions	柄部材質 Shank Material
DPS-05-粒度(Grit)	10x3x120	-
DPS-06-粒度(Grit)	6x3x100	-
DPS-07-粒度(Grit)	4x4x100	-
DPS-08-粒度(Grit)	13x3x100	-
DPS-09-粒度(Grit)	6x2x100	-

棕刷系列 Brush Series

猪毛棕刷 BRISTLE BRUSHES

								
尺寸形狀Size	5D X 6T	6D X 8T	8D X 10T	20D X 2T	25D X 2T	30D X 2T	10D X 7T	15D X 8T
訂購編號Order No.	ABB-A5	ABB-A6	ABB-A8	ABB-T20	ABB-T25	ABB-T30	ABB-F10	ABB-F15

銅綫刷 CUPPER WIRE BRUSHES

								
尺寸形狀Size	5D X 6T	6D X 8T	8D X 10T	20D X 2T	25D X 2T	30D X 2T	10D X 7T	15D X 8T
訂購編號Order No.	ABC-A5	ABC-A6	ABC-A8	ABC-T20	ABC-T25	ABC-T30	ABC-F10	ABC-F15



馬毛棕刷 HORSE BRISTLE BRUSHES

								
尺寸形狀Size	5D X 6T	6D X 8T	8D X 10T	20D X 2T	25D X 2T	30D X 2T	10D X 7T	15D X 8T
訂購編號Order No.	ABH-A5	ABH-A6	ABH-A8	ABH-T20	ABH-T25	ABH-T30	ABH-F10	ABH-F15

不銹鋼刷 STAINLESS STEEL WIRE BRUSHES

								
尺寸形狀Size	5D X 6T	6D X 8T	8D X 10T	20D X 2T	25D X 2T	30D X 2T	10D X 7T	15D X 8T
訂購編號Order No.	ABS-A5	ABS-A6	ABS-A8	ABS-T20	ABS-T25	ABS-T30	ABS-F10	ABS-F15

羊毛棕刷 WOOL BRUSHES

								
尺寸形狀Size	5D X 6T	6D X 8T	8D X 10T	20D X 2T	25D X 2T	30D X 2T	10D X 7T	15D X 8T
訂購編號Order No.	ABW-A5	ABW-A6	ABW-A8	ABW-T20	ABW-T25	ABW-T30	ABW-F10	ABW-F15

含金鋼砂磨料，鋒利耐磨，鋼制的柄軸不易彎曲，適用於工具與模具業等。

Aluminum Oxide Grinding Ping made by PA abrasive. it is high efficiency long tool life make your work effective.

粒度: #120

標準柄徑: 3mm 柄

另可選購: 2.34mm/3.175mm 柄

Grit: #120

Standard: 3mm Shanks

Optional: 2.34mm/3.175mm Shanks

尺寸形狀
Shape

訂購編號
Order No.

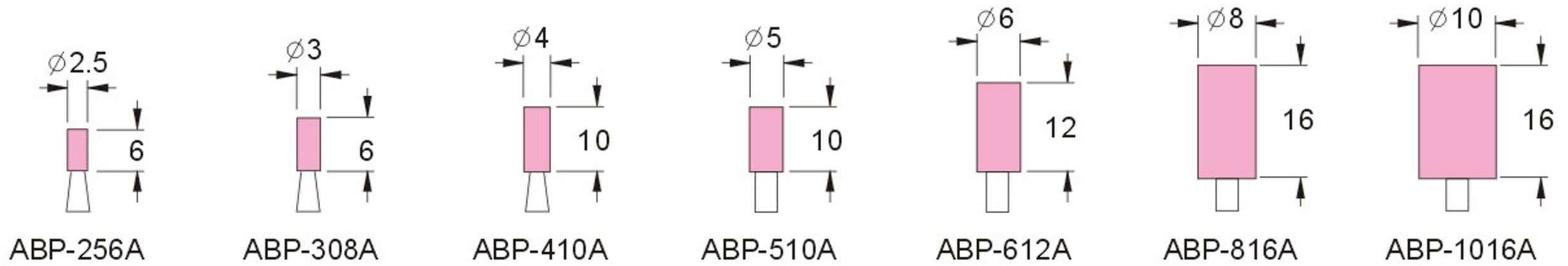

尺寸形狀
Shape

訂購編號
Order No.

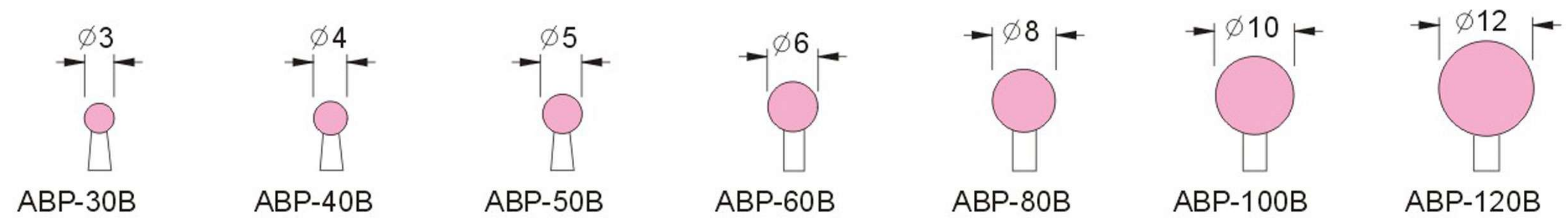

尺寸形狀
Shape

訂購編號
Order No.

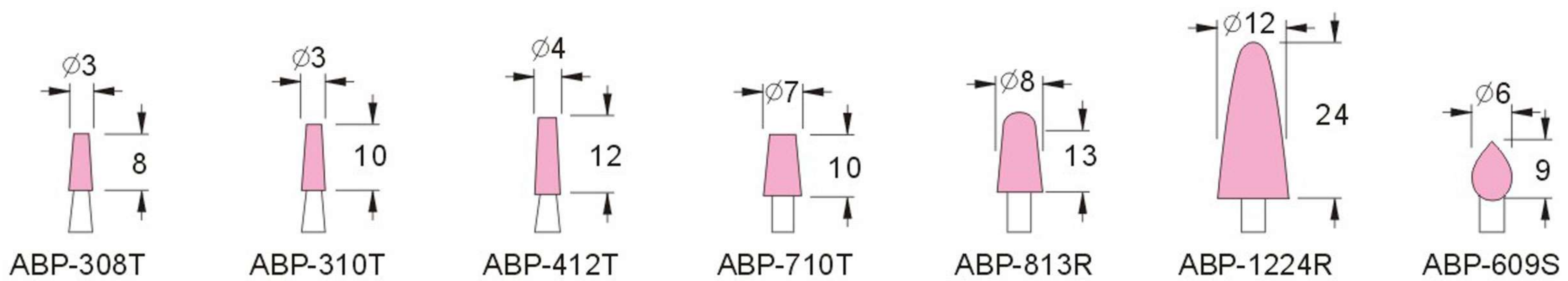

尺寸形狀
Shape

訂購編號
Order No.

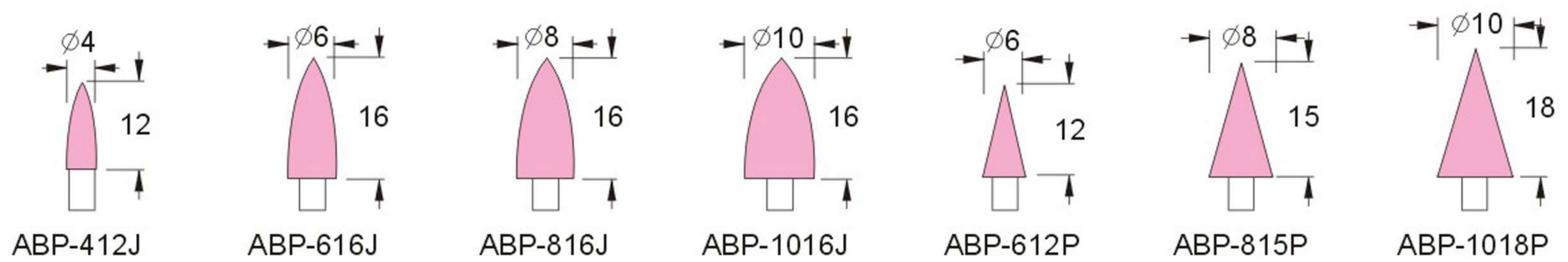

尺寸形狀
Shape

訂購編號
Order No.

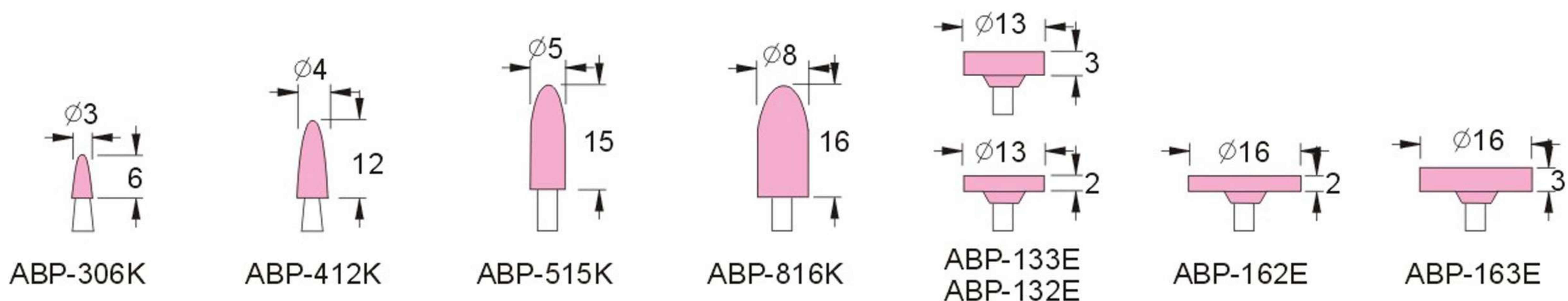

鑽石工具系列 Diamond File Series

DPC

鑽石砂布 Diamond Foil



鑽石砂布是以銅箔為基材，電著上一層鑽石粉，鑽石磨料布滿整個銅箔表面。其特色為有較長之工具壽命，並可以用刀片自行裁減成所需尺寸及形狀，粘貼于各種工具上，成為您所需的自制工具。

其優異的切削效果及多種粒度可供選擇，適合各種模具、鎢鋼、硬陶瓷、石材、玻璃等之研磨及拋光。

Diamond powders are fully sprayed on the surface of copper foil, this features in longer tool life, Fast cutting or polishing on hard steels of tungsten carbides, stones, glass and hard ceramics... etc.

Foil can also be glued to different sized tools and cut to size applied to flexible, adhesive back sheet.

粒度及訂購編號 Grit & Order No.

尺寸 Size	#120	#150	#200	#300	#400	#600	#800	#1200	#1800
10x100mm	DPC-1012	DPC-1015	DPC-1020	DPC-1030	DPC-1040	DPC-1060	DPC-1080	DPC-1120	DPC-1180
50x100mm	DPC-2012	DPC-2015	DPC-2020	DPC-2030	DPC-2040	DPC-2060	DPC-2080	DPC-2120	DPC-2180
100x100mm	DPC-3012	DPC-3015	DPC-3020	DPC-3030	DPC-3040	DPC-3060	DPC-3080	DPC-3120	DPC-3180

鑽石銼刀系列

SP-FLO

德國超微粒光學拋光布 Micro-polierleinen(Made in Germany)

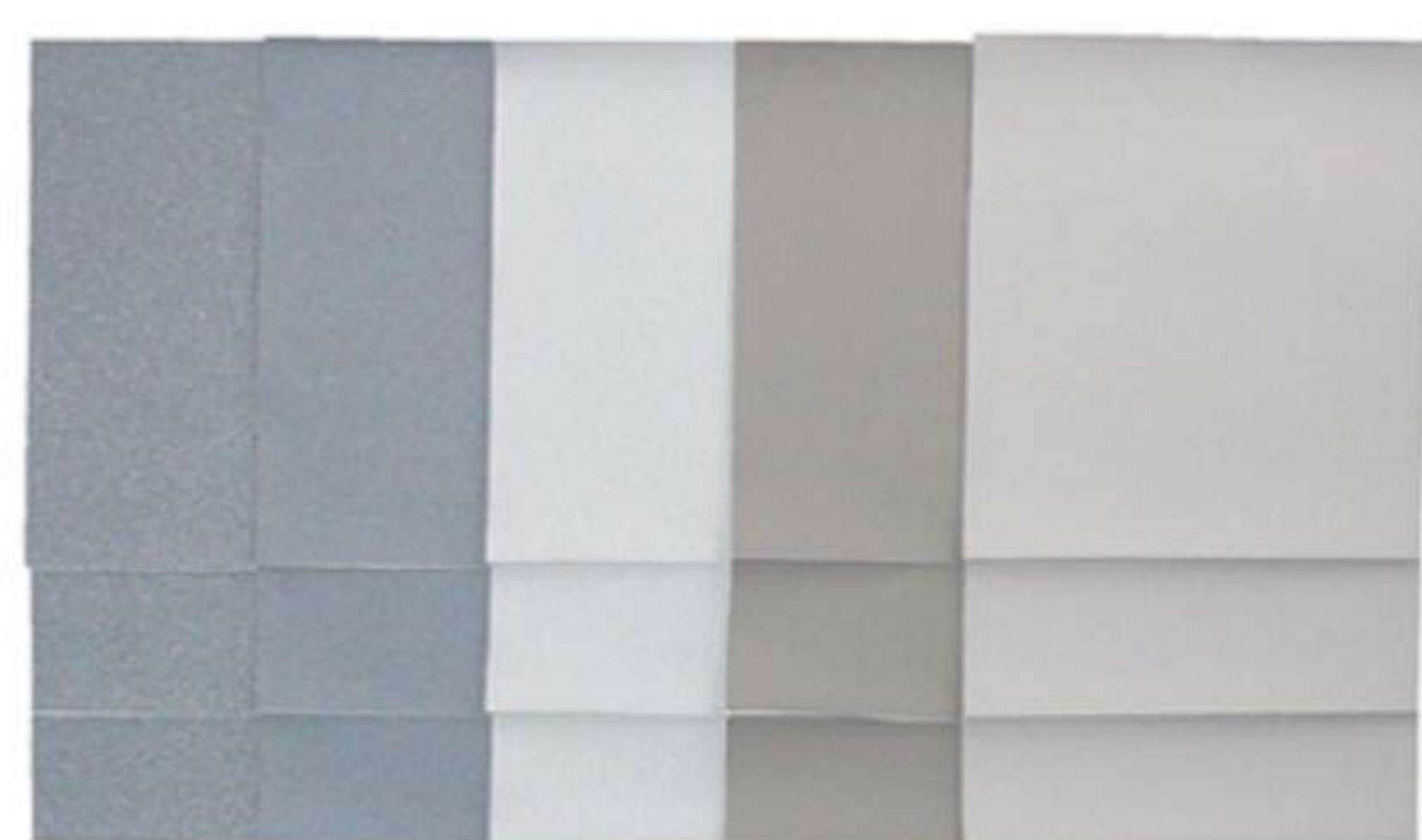

獲得專利的德國超微粒光學拋光布是超精細研磨的最佳選擇。超微粒光學拋光布可應用在不同的材質，如金屬、木材、壓克力、塑料、和玻璃...等。目前美國NASA也將超微粒拋光布使用拋光飛機的側窗。

MICRO-POLIERLEINEN designed for metallographic Applications to fine grind a wide variety latex additive in the cloth. This combination resists water penetration, creating a durable, long-lasting polishing cloth. It is suitable for all kinds of material, like metal, wood, acrylic, plastic, glass... And so forth.

粒度 Grit	尺寸 Size	
	14x15cm(3pcs/set)	15cmx15meters
#1500	SP-FLO-1415-1500	SP-FLO-15015-1500
#1800	SP-FLO-1415-1800	SP-FLO-15015-1800
#2400	SP-FLO-1415-2400	SP-FLO-15015-2400
#3200	SP-FLO-1415-3200	SP-FLO-15015-3200
#4000	SP-FLO-1415-4000	SP-FLO-15015-4000
#6000	SP-FLO-1415-6000	SP-FLO-15015-6000
#8000	SP-FLO-1415-8000	SP-FLO-15015-8000
#12000	SP-FLO-1415-12000	SP-FLO-15015-12000

產品特點：光學產業使用，顆粒細致，適合鏡面研磨使用。

牛皮彈性帶柄砂輪

粒度：#100

用途：一般金屬拋光

COW LEATHER ELASTIC GRINDING PINS

Grit:#100

Application:For Metal Polishing



海綿輪訂購編號 Sponge Elastic Order No.	外徑x厚度x柄徑 OD x Thickness x Shank
ABL-03123	3x12x3mm
ABL-04133	4x13x3mm
ABL-05163	5x16x3mm
ABL-06173	6x17x3mm
ABL-08203	8x20x3mm
ABL-10203	10x20x3mm
ABL-13203	13x20x3mm
ABL-22043	22x4x3mm
ABL-13206	13x20x6mm
ABL-15256	15x25x6mm
ABL-20256	20x25x6mm
ABL-25256	25x25x6mm
ABL-38106	38x10x6mm

海綿彈性帶柄砂輪

粒度：#120

用途：鋁合金及鐵拋光

SPONGE ELASTIC GRINDING PINS

Grit:#120

Application:For Aluminum Alloy and Iron Polishing



海綿輪訂購編號 Sponge Elastic Order No.	外徑x厚度x柄徑 OD x Thickness x Shank
ABR-03123	3x12x3mm
ABR-04133	4x13x3mm
ABR-05163	5x16x3mm
ABR-06173	6x17x3mm
ABR-08203	8x20x3mm
ABR-10203	10x20x3mm
ABR-13203	13x20x3mm
ABR-22043	22x4x3mm
ABR-13206	13x20x6mm
ABR-15256	15x25x6mm
ABR-20256	20x25x6mm
ABR-25256	25x25x6mm
ABR-38106	38x10x6mm

鑽石工具系列 Diamond File Series

ABR-CM

日本制大和海綿輪 Daiwa Rabin(Made in Japan)



Type CM



Type OX



Type UN

尺寸		
Diameter (D)	Length (L)	Shank Diameter (d)
4	13	3
5	15	3
6	17	3
8	20	3
10	20	3
13	20	3
15	17	3
13	20	6
15	20	6
15	25	6
20	25	6
20	37	6
25	25	6
30	30	6

訂購範例: $\frac{\text{ABR-CM}}{\text{型號}} \frac{0413}{\text{尺寸}} \frac{\text{WA}}{\text{磨料}} \frac{80}{\text{粒度}}$ Order Ex: $\frac{\text{ABR-CM}}{\text{Model No.}} \frac{0413}{\text{Size}} \frac{\text{WA}}{\text{Bonding}} \frac{80}{\text{Grit}}$

鑽石銼刀系列

日本[大和磨石]可均勻的拋光物件而不會留下任何刮傷，進而減少加工步驟并改善物件表面粗糙度。因擁有不會造成刮傷與碎屑堵塞的特性，可于鋁制鑄模上進行持續性的加工，無需經歷多次研磨加工過程進而減低工作時程，另可針對各種材料、各式尺寸和形狀來提供最適合去毛邊之磨料。[大和海綿輪]擁有鋒利的研磨特性，因而可以去除硬度較高的工件(如硬度近似HRC60之SKD、HSS、和FCD)上之毛邊或刮痕。它甚至可以在很薄的工作物上研磨，也可以輕易去除白鐵上之焊接痕。

DAIWA RABIN has sharpness enough for grinding and removing tooling marks and burrs even high hardened work materials(such as SKD,HSS and FCD that are around HRC60). It is also able to remove weld bead of stainless of stainless steel and make a polished surface when it is thin.

Type CM

此磨料為大和長期暢銷的產品。優異的切削及其自身的拋光彈性。CM結合劑的特征主要用于壓鑄模和不銹鋼等多種的模具。

It is a long-selling product. The CM type is sharp and excellent in polishing with its own elasticity. The characterized also by versatility applicable to aluminum die casting and stainless steel including molds.

Abrasive Grain:WA-CM grain(Our original abrasive grain has been used.)

Available Grain sizes:#60,80,120,180,220,320

研磨粒: WA-CM

粒度: #60, 80, 120, 180, 220, 320

Type UN

UN擁有比CM更高的硬度，適用于倒角、去毛刺、對付硬質材料鋒利的毛刺以及磨料頭部不易變形的特性。此外，它是能有效維持加工工件的形狀，使成形工件不易變形。對於去除細毛刺或加工精度部分效果尤佳。

It is harder than Type CM and suitable for corner chamfering,de-burring sharp burrs and hard materials,it won't lose its shape easily. In addition,it is efficient when you do not want to lose working form of work piece. It is utilizable for removing fine burrs from and finishing precision part,too.

Abrasive Grain:WA,A,C,GC

Available Grain sizes:#36,46,60,80,120,180,220,320,400,600,800,1000,1500,3000

研磨粒: WA,A,C,GC

粒度: #36,46,60,80,120,180,220,320,400,600,800,1000,1500,3000

Type OX

OX主要適用於精加工拋光時使用。另外它可輕易的清除工件上的生銹并維持模具尺寸，幾乎不損壞工件表面。OX也適合拋光黃金、銅和其他有色金屬。發絲處理的磨粒，磨粒含量比，橡膠的質量和硬度是提供一個均衡的磨料組合。

Use the OX type when emphasis is put on polishing. It removes rust and maintains molds, giving almost no damage to the ground. OX is proper for polishing gold, copper and other non-ferrous metals. A well balanced combination of abrasive grain, abrasive grain concentration, rubber quality and hardness is available for hairline processing.

Abrasive Grain: WA, A, C, GC, Diamond abrasive

Available Grain sizes: #60, 80, 120, 180, 220, 320, 400, 600, 800, 1000, 1500, 3000

研磨粒: WA, A, C, GC, 鑽石磨粒

粒度: #60, 80, 120, 180, 220, 320, 400, 600, 800, 1000, 1500, 3000

Type Urethane(AF)

隨著新開發的聚氨脂泡棉，此款AF類型對於鋁材料的加工可輕易的達到鏡面效果，這是以往難以做到的。同時，我們也提供大直徑研磨輪系列的產品，這是不同與以往傳統的“大和海綿輪”AF磨粒可提供更細的粒度及更綿滑柔軟的加工手感。混合研磨材料開發的聚氨脂泡綿用于研磨鋁材。以商品主題上的氣泡有效防止磨料的堵塞且不留劃痕，并產生一個高層次的拋光表面。對於鋁和銅的材料，該產品是成功地升級現有的拋光效率，改善此特定的工作環境。他還提供了普通鋼和不銹鋼拋光表面不留拋光痕迹的效果。聚氨脂類型給出了一個柔柔軟的觸摸比普通的“大和海綿輪”更具拋光曲綫。這款AF可同時在干磨和濕磨的條件下使用。

With newly developed urethane foam, the type made it easy mirror finish for aluminum materials, which was conventionally difficult to do.

And also, we would like to provide products that are large-diameter wheel series which was not common to conventional

“AIWA RABIN” and make it possible finishing of high meshes with a soft touch.

Urethane foam bond is used which was blended and developed for grinding material. The product prevents clogging with a host of bubbles, leaving no scratch and produces a high-level polished surface. For aluminum and copper materials, the product is successful in upgrading conventional buffing efficiency and improving the working environment a lot. It also provides the polished surface of genral steel and stainless steel without leaving buffing traces. The urethane type gives a softer touch than the conventional “DAIWA RABIN” and readily polishes curves. It is able to use in both of dry and wet conditions.

Abrasive Grain: WA, A, C, GC, Cerium oxide(for glass polishing), Diamond abrasive grain

Available Grain sizes: #80, 120, 180, 220, 320, 400, 600, 800, 1000, 1500, 3000, 6000

研磨粒: WA, A, C, GC, WA-CM. 氧化鈹(用于加工玻璃), 鑽石磨粒。

粒度: #80, 120, 180, 220, 320, 400, 600, 800, 1000, 1500, 3000, 6000

結合劑: AFX

鑽石工具系列 Diamond File Series

CMP/KMP

GS鑽石膏 GS Diamond Compound



鑽石膏適用於模具、超硬合金、陶瓷、寶石...等等之精密拋光及鏡面加工。
本產品依照客戶的需求分為兩種等級，標準品針對寶石加工、中硬度模具...等使用者。如需使用在高硬度模具時，建議您使用較高鑽石等級的鑽石膏。

The diamond compound is using for polishing all kinds of mold, ceramic, jewel and so forth operation.

We divide our quality into 2 levels. For normal jewel and mold makers, we suggest you using standard quality and for professional mold makers, the high quality will be satisfied with your target.

鑽石銼刀系列

高品質代號 Order No.	標準品代號 Order No.	粒度	包裝容量	顆粒尺寸	用途
High Quality	Standard	#Grit	Package(g)	Micron Range(u)	Function
CMP-28000	KMP-28000	28000	5g裝	0.5	鏡面加工用 Mirrorlike Polishing
CMP-14000	KMP-14000	14000		1	
CMP-08000	KMP-08000	8000		3	
CMP-05000	KMP-05000	5000		4.5	精加工用 Fine Polishing
CMP-03000	KMP-03000	3000		6	
CMP-02000	KMP-02000	2000		8	
CMP-01800	KMP-01800	1800		9	
CMP-01500	KMP-01500	1500		13	普通加工 Normal Polishing
CMP-01200	KMP-01200	1200		15	
CMP-01000	KMP-01000	1000		17.5	
CMP-00800	KMP-00800	800		25	
CMP-00600	KMP-00600	600		35	
CMP-00400	KMP-00400	400		50	
CMP-00200	KMP-00200	200		90	粗加工用 Rough Polishing