

刀具系列

銑床配件



F01-F138

刀桿系列

Tool Holder System

刀桿系列

雕刻機用刀桿	F01~F02
高速機用刀桿	F03~F07
後拉式銑刀桿	F08~F29
BT 數控刀桿	F12~F29

刀桿系列

DAT 型刀桿	F30~F39
HSK 型刀桿	F40~F47
NT 型刀桿	F48~F49
莫氏、直式刀桿	F50~F52

刀桿系列

ER 套裝夾頭組	F53~F59
OZ 套裝夾頭組	F60~F64
ST 直式夾頭組	F65~F69
ER 筒夾、BT 拉桿	F70~F82

刀桿系列

清潔棒	F83~F83
鎖刀座	F84~F86
鑽夾頭	F87~F92
絲攻用攻牙器	F93~F106



F01~27 中心加工機用刀柄夾頭



F28~45 中心加工機用刀柄夾頭



INDEX

F46~F52

銑床用刀柄夾頭



62084 F46



62086 F47



62090 F48



62096 F49



62098 F50



62100 F50



62101 F50



62116 F51



62118 F51



62120 F52



62122 F52

F53~F69

銑床用刀柄夾頭(套裝)



62124 F53



62126 F55



62128 F55



62130 F56



62132 F57



62134 F58



62136 F59



62138 F60



62142 F61



62144 F62



62146 F63



62148 F64



62150 F65



62152 F66



62154 F66



62156 F67



62160 F68



62162 F69

F70~F78
銑床用ER筒夾

62168 F71



62169 F71



62170 F72



62171 F72



62172 F73



62173 F73



62174 F74



62175 F74



62176 F75



62177 F75



62178 F76



62179 F76



62180 F77



62181 F77



62182 F78



62183 F78

F79~F83
拉桿螺栓

62232 F79



62234 F79



62236 F80



62238 F80



62240 F80



62242 F80



62250~58 F81



62260~68 F82



62270/75 F83



62290 F83

INDEX

F84~F92

鎖刀座、鑽床、銑床用鑽夾頭



62310 F84



62315 F84



62320 F85



62325 F85



62330 F85



62340 F86



63040 F87



63050 F87



63070 F88



63080 F89



63090 F90



63150 F92

F93~106

快換式絲攻夾頭



63500 F93



63510 F94



63520 F94



63600 F95



63610 F96



63620 F97



63630 F98



63640 F99



63650 F100



63660 F101



63670 F102



63680 F103



63690 F104



63700 F105



63710 F105



63720 F106



63730 F106

刀柄系列 Tooling System

62000

ISO/GSK

雕刻機筒夾刀桿

Engraving Machine Collet Chuck



特點:

- ▶ 無鍵槽適用於高轉速下使用。
- ▶ 刀具置入筒夾內孔,必須超出筒夾內孔有效夾持長度,避免不當鎖固,造成損壞
- ▶ 精密平衡校正可校正: G2.5, 25000RPM。動平衡G2.5, 40000RPM (需另外加價)。

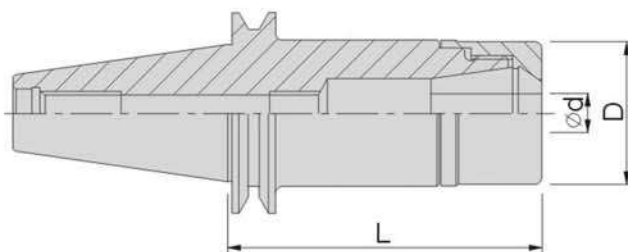

訂購編號 Order No.	型號 Model	∅d	D	L
62000-01	ISO25-GSK6	2~6	20	35
62000-02	ISO25-GSK10	2~10	27.5	35
62000-03	ISO25-GSK16	2~16	40	35
62000-04	ISO30-GSK6	2~6	20	50
62000-05	ISO30-GSK10	2~10	27.5	50
62000-06	ISO30-GSK16	2~16	40	50

62001

GSK

軸承扳手

Wrench



訂購編號 Order No.	型號 Model	扳手孔徑
62001-01	NCH-GSK6	20
62001-02	NCH-GSK10	27.5
62001-03	NCH-GSK16	40

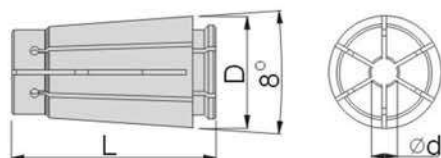

SK筒夾

訂購編號 Order No.	型號 Model	∅d	D	L
P.F06	SK6	2,2.25,2.5,2.75,3,3.5,4,4.5,5,5.5,6	10.55	25
	SK10	2,2.25,2.5,2.75,3,3.5,4,4.5,5,5.5,6,6.5,7,7.5,8,8.5,9,9.5,10	15.5	30
	SK16	4,4.5,5,5.5,6,6.5,7,7.5,8,8.5,9,9.5,10,10.5,11,11.5,12,12.5,13,13.5,14,14.5,15,15.5,16	24.5	40

62002
ISO/GER
雕刻機筒夾刀桿 Engraving Machine Collet Chuck

特點:

- ▶ 無鍵槽適用於高轉速下使用。
- ▶ 刀具置入筒夾內孔,必須超出筒夾內孔有效夾持長度,避免不當鎖固,造成損壞
- ▶ 精密平衡校正可校正在: G2.5, 25000RPM。動平衡G2.5, 40000RPM (需另外加價)。

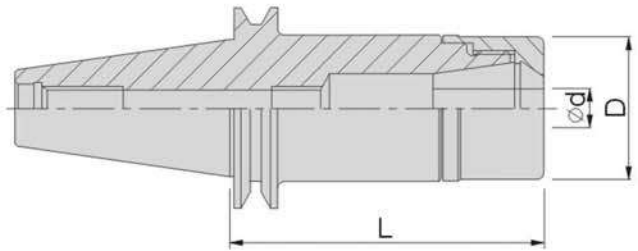
 TOOLING SYSTEM
 刀柄系列

訂購編號 Order No.	型號 Model	∅d	D	L
62002-01	ISO25-GER16	2~10	27.5	42
62002-02	ISO25-GER20	2~13	30	42
62002-03	ISO30-GER16	2~10	27.5	55
62002-04	ISO30-GER20	2~13	30	55

62003
GER
軸承扳手 Wrench

訂購編號 Order No.	型號 Model	扳手孔徑
62003-01	NCH-GER16	27.5
62003-02	NCH-GER20	30
62003-03	NCH-GER25	40

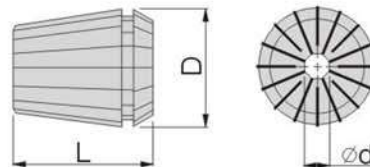
ER筒夾

訂購編號 Order No.	型號 Model	∅d	D	L
PF72~74	ER11	2,2.5,3,3.5,4,4.5,5,5.5,6,6.5,7	11.5	18.5
	ER16	2,2.5,3,3.5,4,4.5,5,5.5,6,6.5,7,7.5,8,8.5,9,9.5,10	17	27
	ER20	2,2.5,3,3.5,4,4.5,5,5.5,6,6.5,7,7.5,8,8.5,9,9.5,10,10.5,11,11.5,12,12.5,13	21	31

刀柄系列 Tooling System

62004

BT/GSK

高速刀桿 High Speed Chuck



特點:

- ▲ GSK系列適用於高轉速、高精密切削,增加刀具壽命。
- ▲ 切削性穩定、減少震動。
- ▲ 刀具置入筒夾內孔,必須超出筒夾內孔有效夾持長度,避免不當鎖固,造成損壞
- ▲ 精密平衡校正可校正: G2.5, 25000RPM~32000RPM。

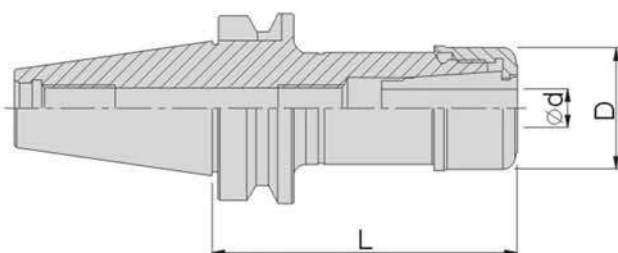

P.F05

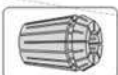

P.F06

訂購編號 Order No.	型號 Model	∅d	D	L
62004-01	BT30-GSK6-60	1.8~6.00	20	60
62004-02	BT30-GSK6-100	1.8~6.00	20	100
62004-03	BT30-GSK10-60	1.8~10.00	27.5	60
62004-04	BT30-GSK10-90	1.8~10.00	27.5	90
62004-05	BT30-GSK16-60	2.75~16.00	40	60
62004-06	BT30-GSK16-90	2.75~16.00	40	90
62004-07	BT40-GSK6-60	1.8~6.00	20	60
62004-08	BT40-GSK6-90	1.8~6.00	20	90
62004-09	BT40-GSK10-60	1.8~10.00	27.5	60
62004-10	BT40-GSK10-90	1.8~10.00	27.5	90
62004-11	BT40-GSK16-60	2.75~16.00	40	60
62004-12	BT40-GSK16-90	2.75~16.00	40	90

軸承扳手



訂購編號 Order No.	型號 Model	扳手孔徑
P F01	NCH-GSK6	20
	NCH-GSK10	27.5
	NCH-GSK16	40

62006
BT/TSK
高速刀桿 High Speed Chuck

 刀柄系列
TOOLING SYSTEM

特點:

- ▶ TSK系列適用於高轉速、高精密切削,增加刀具壽命。
- ▶ 切削性穩定、減少震動。
- ▶ 刀具置入筒夾內孔,必須超出筒夾內孔有效夾持長度,避免不當鎖固,造成損壞
- ▶ 精密平衡校正可校正: G2.5, 15000RPM~25000RPM。

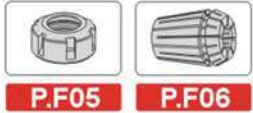
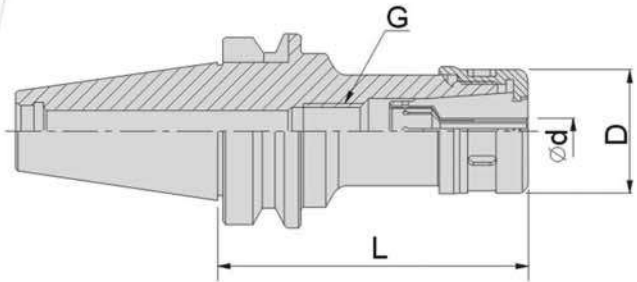

訂購編號 Order No.	型號 Model	Ød	D	L	G
62006-01	BT30-TSK6-60	1.8~6.00	20	60	M8 x 1.25P
62006-02	BT30-TSK6-100	1.8~6.00	20	100	M8 x 1.25P
62006-03	BT30-TSK10-60	1.8~10.00	29	60	M12 x 1.75P
62006-04	BT30-TSK10-100	1.8~10.00	29	100	M12 x 1.75P
62006-05	BT30-TSK16-60	2.75~16.00	40	60	M18 x 2.5P
62006-06	BT30-TSK16-100	2.75~16.00	40	100	M18 x 2.5P
62006-07	BT40-TSK6-60	1.8~6.00	20	60	M8 x 1.25P
62006-08	BT40-TSK6-100	1.8~6.00	20	100	M8 x 1.25P
62006-09	BT40-TSK10-60	1.8~10.00	29	60	M12 x 1.75P
62006-10	BT40-TSK10-100	1.8~10.00	29	100	M12 x 1.75P
62006-11	BT40-TSK16-60	2.75~16.00	40	60	M18 x 2.5P
62006-12	BT40-TSK16-100	2.75~16.00	40	100	M18 x 2.5P
62006-13	BT40-TSK25-80	8.00~25.00	55	80	M24 x 3.0P
62006-14	BT40-TSK25-120	8.00~25.00	55	120	M24 x 3.0P
62006-15	BT50-TSK10-100	1.8~10.00	29	100	M12 x 1.75P
62006-16	BT50-TSK10-150	1.8~10.00	29	150	M12 x 1.75P
62006-17	BT50-TSK16-100	2.75~16.00	40	100	M18 x 2.5P
62006-18	BT50-TSK16-150	2.75~16.00	40	150	M18 x 2.5P
62006-19	BT50-TSK25-120	8.00~25.00	55	120	M24 x 3.0P
62006-20	BT50-TSK25-200	8.00~25.00	55	200	M24 x 3.0P

刀桿螺帽專用扳手

P.F05



刀柄系列 Tooling System

62008

TSK/GSK

刀桿螺帽 Clamping Nut

刀柄系列
TOOLING SYSTEM

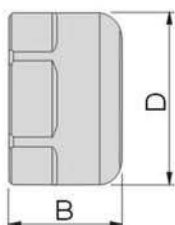

TSK

訂購編號 Order No.	型號 Model	D	B
62008-01	NUT-TSK6	20	16
62008-02	NUT-TSK10	29	19
62008-03	NUT-TSK16	40	27.5
62008-04	NUT-TSK25	55	34

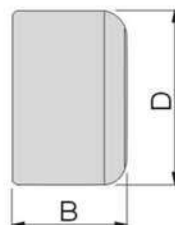

GSK

訂購編號 Order No.	型號 Model	D	B
62008-05	NUT-GSK6	20	16
62008-06	NUT-GSK10	27.5	19
62008-07	NUT-GSK16	40	27.5

62009

TSK

刀桿螺帽專用扳手 Wrench

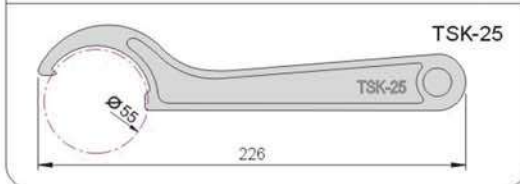
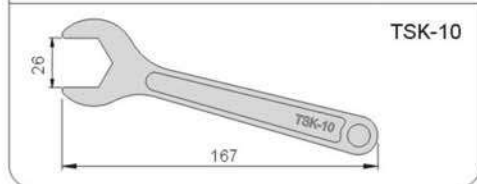
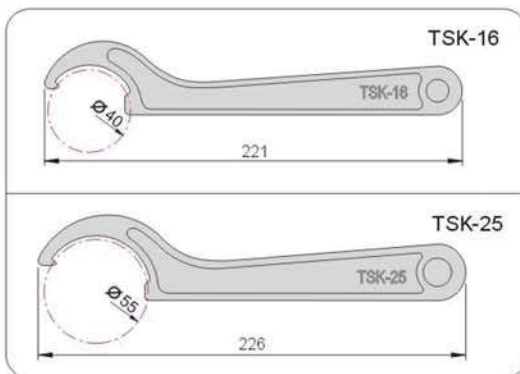
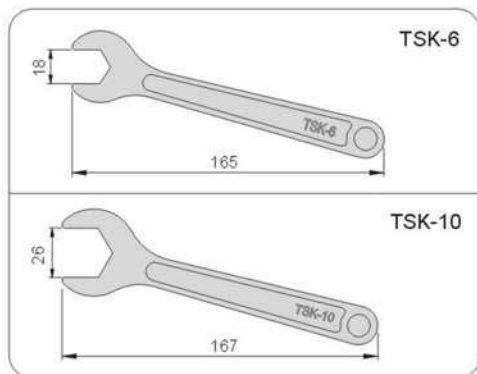

單位:mm

訂購編號	型號
62009-01	TSK-6
62009-02	TSK-10
62009-03	TSK-16
62009-04	TSK-25

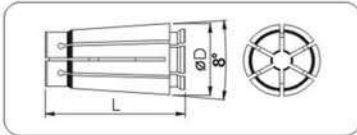

SK6

訂購編號	型號	範圍
62010-01	SK6-2	1.80~2
62010-02	SK6-3	2.8~3
62010-03	SK6-3.5	3~3.5
62010-04	SK6-4	3.5~4
62010-05	SK6-4.5	4~4.5
62010-06	SK6-5	4.5~5
62010-07	SK6-5.5	5~5.5
62010-08	SK6-6	5.5~6

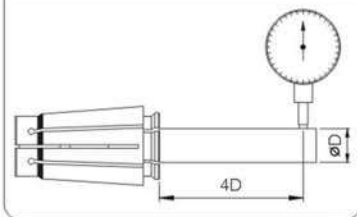

	D	L
SK6	10.55	25
SK10	15.60	30
SK16	24.6	45
SK25	35.6	57

Collect level	Runout
P	3 um
A	5 um

SK10

訂購編號	型號	範圍
62010-11	SK10-2	1.80~2
62010-12	SK10-3	2.8~3
62010-13	SK10-3.5	3~3.5
62010-14	SK10-4	3.5~4
62010-15	SK10-4.5	4~4.5
62010-16	SK10-5	4.5~5
62010-17	SK10-5.5	5~5.5
62010-18	SK10-6	5.5~6
62010-19	SK10-6.5	6~6.5
62010-20	SK10-7	6.5~7
62010-21	SK10-7.5	7~7.5
62010-22	SK10-8	7.5~8
62010-23	SK10-8.5	8~8.5
62010-24	SK10-9	8.5~9
62010-25	SK10-9.5	9~9.5
62010-26	SK10-10	9.5~10

	SK6-2 ~SK6-2.75 SK10-2~SK10-2.75
	SK6-3 ~SK6-6 SK10-3~SK10-6 SK16-3~SK16-6
	SK10-6.5~SK10-8 SK16-6.5~SK16-16 SK25-8~SK25-25

SK16

訂購編號	型號	範圍
62010-31	SK16-3	2.8~3
62010-32	SK16-3.5	3~3.5
62010-33	SK16-4	3.5~4
62010-34	SK16-4.5	4~4.5
62010-35	SK16-5	4.5~5
62010-36	SK16-5.5	5~5.5
62010-37	SK16-6	5.5~6
62010-38	SK16-6.5	6~6.5
62010-39	SK16-7	6.5~7
62010-40	SK16-7.5	7~7.5
62010-41	SK16-8	7.5~8
62010-42	SK16-8.5	8~8.5
62010-43	SK16-9	8.5~9
62010-44	SK16-9.5	9~9.5
62010-45	SK16-10	9.5~10
62010-46	SK16-10.5	10~10.5
62010-47	SK16-11	10.5~11
62010-48	SK16-11.5	11~11.5
62010-49	SK16-12	11.5~12
62010-50	SK16-12.5	12~12.5
62010-51	SK16-13	12.5~13
62010-52	SK16-13.5	13~13.5
62010-53	SK16-14	13.5~14
62010-54	SK16-14.5	14~14.5
62010-55	SK16-15	14.5~15
62010-56	SK16-15.5	15~15.5
62010-57	SK16-16	15.5~16

SK25

訂購編號	型號	範圍
62010-61	SK25-8	7.5~8
62010-62	SK25-10	9.5~10
62010-63	SK25-12	11.5~12
62010-64	SK25-16	15.5~16
62010-65	SK25-16.5	16~16.5
62010-66	SK25-17	16.5~17
62010-67	SK25-17.5	17~17.5
62010-68	SK25-18	17.5~18
62010-69	SK25-18.5	18~18.5
62010-70	SK25-19	18.5~19
62010-71	SK25-19.5	19~19.5
62010-72	SK25-20	19.5~20
62010-73	SK25-20.5	20~20.5
62010-74	SK25-21	20.5~21
62010-75	SK25-21.5	21~21.5
62010-76	SK25-22	21.5~22
62010-77	SK25-22.5	22~22.5
62010-78	SK25-23	22.5~23
62010-79	SK25-23.5	23~23.5
62010-80	SK25-24	23.5~24
62010-81	SK25-24.5	24~24.5
62010-82	SK25-25	24.5~25

刀柄系列 Tooling System

62012

BT/GER

高速刀桿 High Speed Chuck

特點:

- ▲ 適用於高轉速、高精密切削,增加刀具壽命。切削性穩定、減少震動。
- ▲ 刀具置入筒夾內孔,必須超出筒夾內孔有效夾持長度,避免不當鎖固,造成損壞
- ▲ 精密平衡校正可校正: G2.5, 15000RPM~25000RPM。

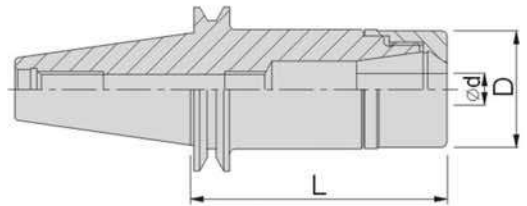

訂購編號 Order No.	型號 Model	ϕd	D	L
62012-01	BT30-GER16-70	0.5~10.0	27.5	70
62012-02	BT30-GER20-70	1.0~13.0	30	70
62012-03	BT30-GER25-70	1.0~16.0	40	70
62012-04	BT30-GER16-100	0.5~10.0	27.5	100
62012-05	BT30-GER20-100	1.0~13.0	30	100
62012-06	BT30-GER25-100	1.0~16.0	40	100
62012-07	BT40-GER16-70	0.5~10.0	27.5	70
62012-08	BT40-GER20-70	1.0~13.0	30	70
62012-09	BT40-GER25-70	1.0~16.0	40	70
62012-10	BT40-GER16-100	0.5~10.0	27.5	100
62012-11	BT40-GER20-100	1.0~13.0	30	100
62012-12	BT40-GER25-100	1.0~16.0	40	100

軸承扳手



ER筒夾

訂購編號 Order No.	型號 Model	扳手孔徑
P. F02	NCH-GER16	27.5
	NCH-GER20	30
	NCH-GER25	40

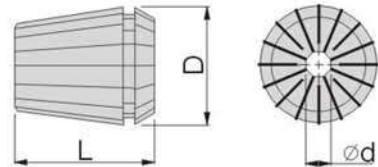

訂購編號 Order No.	型號 Model	ϕd	D	L
P. F72~75	ER11	2,2.5,3,3.5,4,4.5,5,5.5,6,6.5,7	11.5	18.5
	ER16	2,2.5,3,3.5,4,4.5,5,5.5,6,6.5,7,7.5,8,8.5,9,9.5,10	17	27
	ER20	2,2.5,3,3.5,4,4.5,5,5.5,6,6.5,7,7.5,8,8.5,9,9.5,10,10.5,11,11.5,12,12.5,13	21	31
	ER25	3,4,5,6,7,8,9,10,11,12,13,14,15,16	26	35

62014
BT/SBL
後拉式立銑刀桿 Slim-Fit Collet Chuck

P.F11
特點:

JIS B 6339(MAS 403 BT)

- ▶ 後拉式刀把採用後拉式筒夾夾持,適用於高速精密之加工。
- ▶ 刀具置入筒夾內孔,必須超出筒夾內孔有效夾持長度,避免不當鎖固,造成損壞。

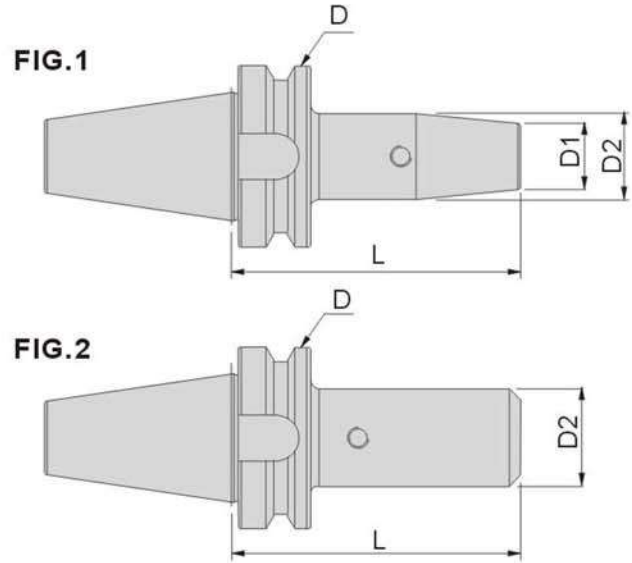

單位:mm

訂購編號 Order No.	型號 Model	L	Ø D	Ø D1	Ø D2	FIG.圖
62014-01	BT30xSBL6-70	70	46	23	30	1
62014-02	BT30xSBL6-100	100	46	23	30	1
62014-03	BT30xSBL12-70	70	46	-	34	2
62014-04	BT30xSBL12-100	100	46	-	34	2
62014-05	BT30xSBL20-85	85	46	-	42	2
62014-06	BT30xSBL20-100	100	46	-	42	2
62014-07	BT40xSBL6-70	70	63	23	30	1
62014-08	BT40xSBL6-100	100	63	23	30	1
62014-09	BT40xSBL12-70	70	63	-	34	2
62014-10	BT40xSBL12-100	100	63	-	34	2
62014-11	BT40xSBL20-75	75	63	-	48	2
62014-12	BT40xSBL20-100	100	63	-	48	2
62014-13	BT50xSBL6-70	70	100	23	28	1
62014-14	BT50xSBL6-100	100	100	23	28	1
62014-15	BT50xSBL12-70	70	100	-	34	2
62014-16	BT50xSBL12-100	100	100	-	34	2
62014-17	BT50xSBL20-70	70	100	-	48	2
62014-18	BT50xSBL20-100	100	100	-	48	2



刀柄系列 Tooling System

62016

SK/SBL 後拉式立銑刀桿 Slim-Fit Collet Chuck

刀柄系列
TOOLING SYSTEM



特點:

DIN 69871-A

- ▶ 後拉式刀把採用後拉式筒夾夾持,適用於高速精密之加工。
- ▶ 刀具置入筒夾內孔,必須超出筒夾內孔有效夾持長度,避免不當鎖固,造成損壞。

FIG.1

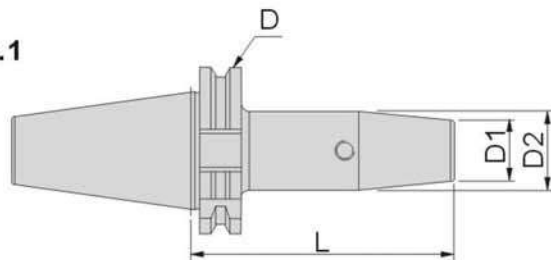
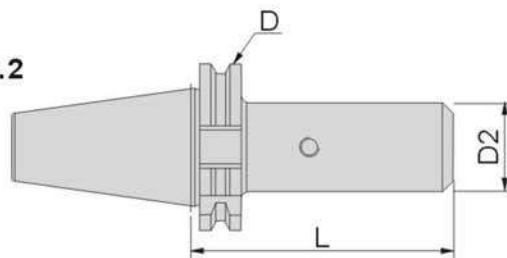

FIG.2



P.F11

單位:mm

訂購編號 Order No.	型號 Model	L	Ø D	Ø D1	Ø D2	FIG.圖
62016-01	SK30xSBL6-70	70	50	23	30	1
62016-02	SK30xSBL6-100	100	50	23	30	1
62016-03	SK30xSBL12-80	80	50	-	34	2
62016-04	SK30xSBL12-100	100	50	-	34	2
62016-05	SK30xSBL20-80	80	50	-	42	2
62016-06	SK30xSBL20-100	100	50	-	42	2
62016-07	SK40xSBL6-70	70	63.55	23	30	1
62016-08	SK40xSBL6-100	100	63.55	23	30	1
62016-09	SK40xSBL12-80	80	63.55	-	34	2
62016-10	SK40xSBL12-100	100	63.55	-	34	2
62016-11	SK40xSBL20-80	80	63.55	-	42	2
62016-12	SK40xSBL20-100	100	63.55	-	42	2
62016-13	SK50xSBL6-70	70	97.5	23	30	1
62016-14	SK50xSBL6-100	100	97.5	23	30	1
62016-15	SK50xSBL12-70	70	97.5	-	34	2
62016-16	SK50xSBL12-100	100	97.5	-	34	2
62016-17	SK50xSBL20-80	80	97.5	-	42	2
62016-18	SK50xSBL20-100	100	97.5	-	42	2



特點:

DIN 69893-1A

- ▶ 後拉式刀把採用後拉式筒夾夾持,適用於高速精密之加工。
- ▶ 刀具置入筒夾內孔,必須超出筒夾內孔有效夾持長度,避免不當鎖固,造成損壞。
- ▶ 搭配HSK兩面拘束,可增加側向加工的穩定性。

 TOOLING SYSTEM
刀柄系列

FIG.1

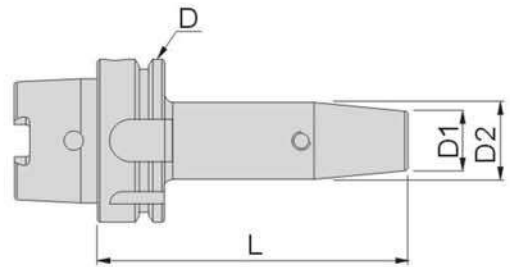
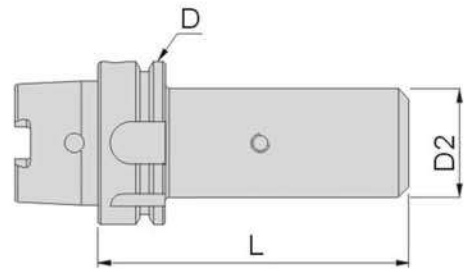

FIG.2



P.F11

單位:mm

訂購編號 Order No.	型號 Model	L	Ø D	Ø D1	Ø D2	FIG.圖
62018-01	HSK50AxSBL6-105	105	50	23	30	1
62018-02	HSK50AxSBL6-120	120	50	23	30	1
62018-03	HSK50AxSBL12-120	120	50	-	34	2
62018-04	HSK50AxSBL12-130	130	50	-	34	2
62018-05	HSK50AxSBL20-130	130	50	-	42	2
62018-06	HSK50AxSBL20-150	150	50	-	42	2
62018-07	HSK63AxSBL6-110	110	63	23	30	1
62018-08	HSK63AxSBL6-120	120	63	23	30	1
62018-09	HSK63AxSBL12-120	120	63	-	42	2
62018-10	HSK63AxSBL12-150	150	63	-	42	2
62018-11	HSK63AxSBL20-130	130	63	-	42	2
62018-12	HSK63AxSBL20-140	140	63	-	42	2



刀柄系列 Tooling System

62020

SBL

後拉筒夾 Collet



刀柄系列
TOOLING SYSTEM



特點:

▶ 它適用於各種的加工, 包含鑽孔, 銑床, 攻牙。

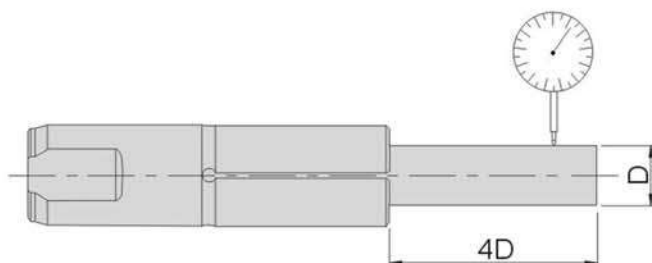

型號	D	L
SBL6	∅14.7	52.4
SBL12	∅17.8	64.2
SBL20	∅26.1	69.9

訂購編號 Order No.	型號 Model	∅D 柄徑
62020-01	SBL6	∅3
62020-02	SBL6	∅4
62020-03	SBL6	∅4.5
62020-04	SBL6	∅5.5
62020-05	SBL6	∅6

訂購編號 Order No.	型號 Model	∅D 柄徑
62020-21	SBL12	∅4
62020-22	SBL12	∅6
62020-23	SBL12	∅8
62020-24	SBL12	∅10
62020-25	SBL12	∅12

訂購編號 Order No.	型號 Model	∅D 柄徑
62020-51	SBL20	∅6
62020-52	SBL20	∅8
62020-53	SBL20	∅10
62020-54	SBL20	∅12
62020-55	SBL20	∅14
62020-56	SBL20	∅16
62020-57	SBL20	∅18
62020-58	SBL20	∅20

特點:

- ▶ 開槽: 刀桿內孔開槽(分割6槽), 以防止滑動, 並加大夾持力。
- ▶ 滾針軸承: 採用兩線裝置, 確保滑動至針錐面時滾動摩擦及脫落減至最小。
- ▶ 防水及防塵, 夾緊後端面接觸。
- ▶ 此設計結構不會過分緊固而損傷夾頭。
- ▶ 密封式結構, 以消除污垢和碎片損害夾頭。
- ▶ 動平衡可以達到G6.3, 8000RPM。
- ▶ 平衡等級和轉速可以根據客戶的要求, 但需另行報價。

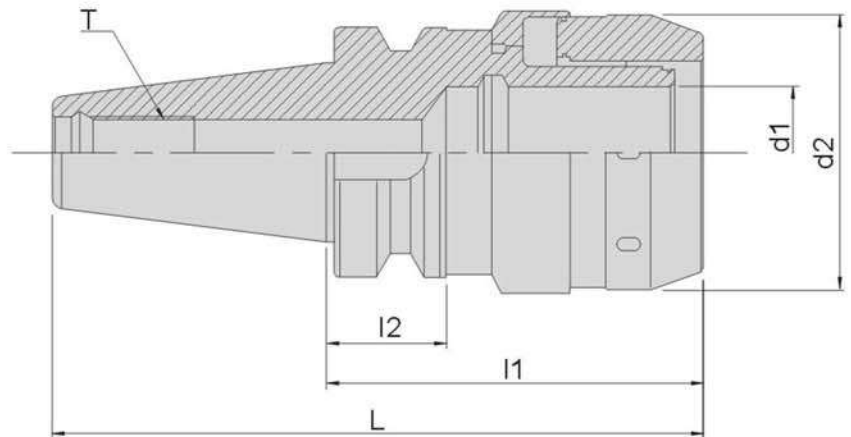
P.F82
P.F67

單位: mm

訂購編號 Order No.	型號-d1-l1 Model	L	l1	l2	d1	d2	T
62022-01	BT30-C20-80	128.4	80	20	20	55	M12x1.75
62022-02	BT40-C20-80	145.4	80	25	32	68.5	
62022-03	BT40-C20-100	165.4	100	25	32	68.5	
62022-04	BT40-C20-135	200.4	135	25	32	68.5	
62022-05	BT40-C25-80	145.4	80	25	32	68.5	M16x2.0
62022-06	BT40-C25-100	165.4	100	25	32	68.5	
62022-07	BT40-C32-90	155.4	90	25	32	68.5	
62022-08	BT40-C32-105	170.4	105	25	32	68.5	
62022-09	BT40-C32-135	200.4	135	25	32	68.5	M24x3.0
62022-10	BT50-C32-110	211.8	110	35	32	68.5	
62022-11	BT50-C32-135	236.8	135	35	32	68.5	
62022-12	BT50-C32-165	266.8	165	35	32	68.5	
62022-13	BT50-C32-200	301.8	200	35	32	68.5	
62022-14	BT50-C42-110	211.8	110	35	42	92	

刀柄系列 Tooling System

62025

BT/HC

直筒式強力型刀桿 Multi-Lock Milling Chuck

刀柄系列
TOOLING SYSTEM



特點:

- ▲ 防水及防塵, 夾緊後端面接觸。
- ▲ 此設計結構不會過分緊固而損傷夾頭。
- ▲ 密封式結構, 以消除污垢和碎片損害夾頭。
- ▲ 動平衡可以達到G6.3, 8000RPM。
- ▲ 平衡等級和轉速可以根據客戶的要求, 但需另行報價。

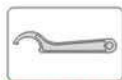
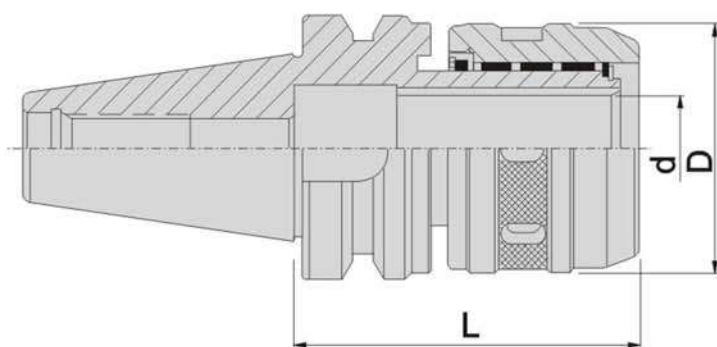

P.F82

P.F67

訂購編號 Order No.	型號-d-L Model	d	D	L	Capacity	重量 N.W.
62025-05	BT40-HC20-90	20	50	90	3-16;20	2.1kg
62025-06	BT40-HC25-100	25	59	105	3-20;25	2.6kg
62025-07	BT40-HC32-90	32	70	90	3-25;32	3.0kg
62025-08	BT40-HC32-105	32	70	105	3-25;32	3.4kg
62025-09	BT40-HC42-105	42	99	105	3-32;42	5.6kg
62025-10	BT50-HC20-105	20	50	105	3-16;20	5.7kg
62025-11	BT50-HC25-105	25	59	105	3-20;25	6.1kg
62025-12	BT50-HC32-110	32	70	110	3-25;32	6.8kg
62025-13	BT50-HC32-165	32	70	165	3-25;32	8.9kg
62025-14	BT50-HC42-105	42	99	105	3-32;42	10.2kg
62025-15	BT50-HC42-165	42	99	165	3-32;42	13.3kg

62026
BT/ER
立銑刀夾頭 Collet Chuck

特點:
DIN ISO 15488

- ▲ 螺紋經精密磨削。
- ▲ ER16, ER20緊固螺母為外六角螺母。
- ▲ 可以額外購買強力螺母。
- ▲ 動平衡可以達到G6.3, 10000RPM。
- ▲ 平衡等級和轉速可以根據客戶的要求,但需另行報價。

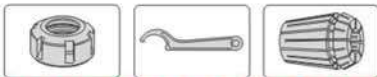
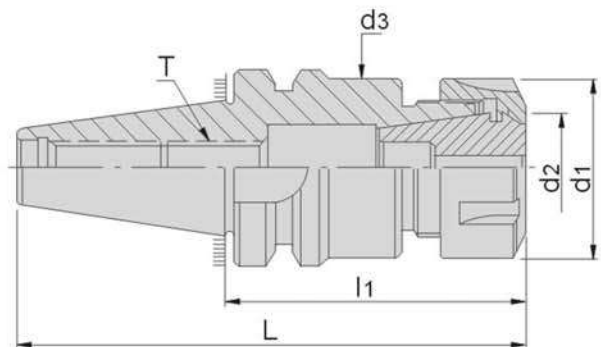
 刀柄系列
TOOLING SYSTEM

P.F81 P.F82 P.F73-77

單位:mm

訂購編號 Order No.	型號-d2-l1 Model	L	d1	d2 ER	d3	T	夾持範圍	重量 N.W.
62026-01	BT30xER16A-50	98.4	28	16	28	M10x1.5P	0.5~10.0	0.45kg
62026-02	BT30xER16A-70	118.4	28	16	28			0.55kg
62026-03	BT30xER16A-60	108.4	28	16	28			0.60kg
62026-04	BT30xER16A-100	148.4	28	16	28			0.80kg
62026-05	BT30xER16A-120	168.4	28	16	28			0.95kg
62026-06	BT30xER20A-50	98.4	34	20	34	M12x1.75P	1.0~13.0	0.48kg
62026-07	BT30xER20A-70	118.4	34	20	34			0.75kg
62026-08	BT30xER20A-135	183.4	34	20	34			1.15kg
62026-09	BT30xER25-70	118.4	42	25	42	M16x2.0P	1.0~16.0	0.70kg
62026-10	BT30xER25-135	183.4	42	25	42			1.45kg
62026-11	BT30xER32-70	118.4	50	32	45		2.0~20.0	0.85kg
62026-12	BT30xER32-100	148.4	50	32	45			1.00kg
62026-13	BT30xER40-80	128.4	63	40	53			3.0~26.0

刀柄系列 Tooling System

62026

BT/ER

立銑刀夾頭 Collet Chuck

刀柄系列
TOOLING SYSTEM



特點:

DIN ISO 15488

- ▶ 可夾持直柄銑刀、鑽頭、絲攻等工具。
- ▶ ER16, ER20附有一個六角螺母。
- ▶ ER25, ER32, ER40, ER50附有一個標準螺母, 可以額外購買強力螺母。
- ▶ 動平衡可以達到G6.3, 10000RPM。
- ▶ 平衡等級和轉速可以根據客戶的要求, 但需另行報價。

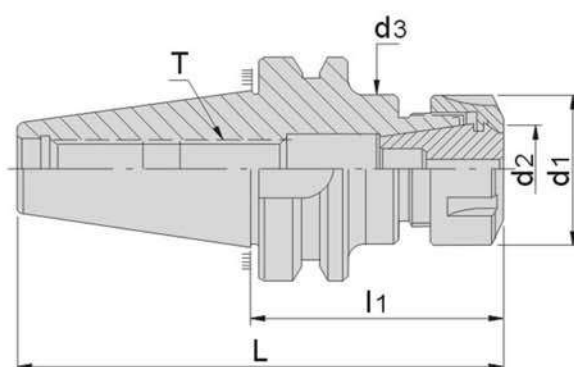

單位:mm

訂購編號 Order No.	型號-d2-l1 Model	L	d1	d2 ER	d3	T	夾持範圍	重量 N.W.
62026-14	BT40xER16A-70	135.4	28	16	28	M10x1.5P	0.5~10.0	1.20kg
62026-15	BT40xER16A-100	165.4						1.30kg
62026-16	BT40xER16A-125	190.4						1.36kg
62026-17	BT40xER16A-150	215.4						1.54kg
62026-18	BT40xER16A-180	245.4						2.00kg
62026-19	BT40xER20A-70	135.4	34	20	34	M12x1.75P	1.0~13.0	1.40kg
62026-20	BT40xER20A-100	165.4						1.50kg
62026-21	BT40xER20A-135	200.4						1.70kg
62026-22	BT40xER20A-150	215.4						1.80kg
62026-23	BT40xER25-70	135.4	42	25	42	M16x2.0P	1.0~16.0	1.30kg
62026-24	BT40xER25-100	165.4						1.50kg
62026-25	BT40xER25-125	190.4						1.90kg
62026-26	BT40xER25-150	215.4						2.25kg
62026-27	BT40xER32-70	135.4						50
62026-28	BT40xER32-100	165.4	1.70kg					
62026-29	BT40xER32-150	215.4	2.50kg					
62026-30	BT40xER40-80	145.4	63	40	53	M20x2.0P	3.0~26.0	
62026-31	BT40xER40-100	165.4						2.05kg
62026-32	BT40xER40-120	185.4						2.50kg
62026-33	BT40xER40-150	215.4						3.10kg
62026-34	BT40xER50-85	150.4						78
62026-35	BT40xER50-100	165.4	2.10kg					

特點:
DIN ISO 15488

- ▶ 可夾持直柄銑刀、鑽頭、絲攻等工具。
- ▶ ER16, ER20附有一個六角螺母。
- ▶ ER25, ER32, ER40, ER50附有一個標準螺母, 可以額外購買強力螺母。
- ▶ 動平衡可以達到G6.3, 10000RPM。
- ▶ 平衡等級和轉速可以根據客戶的要求, 但需另行報價。

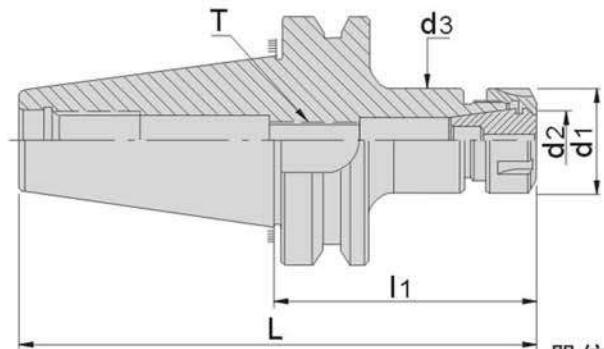

單位:mm

P.F81 P.F82 P.F73-78

訂購編號 Order No.	型號-d2-l1 Model	L	d1	d2 ER	d3	T	夾持範圍	重量 N.W.			
62026-36	BT50xER16A-70	171.8	28	16	28	M10x1.5P	0.5~10.0	4.05kg			
62026-37	BT50xER16A-90	191.8						4.20kg			
62026-38	BT50xER16A-105	206.8						4.30kg			
62026-39	BT50xER16A-135	236.8						4.40kg			
62026-40	BT50xER16A-150	251.8						4.50kg			
62026-41	BT50xER16A-165	266.8						4.50kg			
62026-42	BT50xER20A-70	171.8	34	20	34	M12x1.75P	4.20kg				
62026-43	BT50xER20A-90	191.8					4.25kg				
62026-44	BT50xER20A-105	206.8					4.30kg				
62026-45	BT50xER20A-135	236.8					4.55kg				
62026-46	BT50xER20A-150	251.8					4.70kg				
62026-47	BT50xER20A-165	266.8					4.80kg				
62026-48	BT50xER20A-200	301.8	42	25	42	1.0~16.0	4.90kg				
62026-49	BT50xER25-70	171.8					4.20kg				
62026-50	BT50xER25-105	206.8					4.40kg				
62026-51	BT50xER25-135	236.8					4.70kg				
62026-52	BT50xER25-165	266.8					5.00kg				
62026-53	BT50xER32-80	181.8					50	40	50	M16x2.0P	4.70kg
62026-54	BT50xER32-100	201.8	4.80kg								
62026-55	BT50xER32-120	221.8	4.90kg								
62026-56	BT50xER32-150	251.8	5.30kg								
62026-57	BT50xER32-200	301.8	5.50kg								
62026-58	BT50xER40-80	181.8	63	40	63	M20x2.0P					4.30kg
62026-59	BT50xER40-100	201.8					4.40kg				
62026-60	BT50xER40-120	221.8					5.20kg				
62026-61	BT50xER40-135	236.8					5.50kg				
62026-62	BT50xER50-90	191.8					78	50	78	M24x2.0P	4.60kg
62026-63	BT50xER50-120	221.8									5.50kg
62026-64	BT50xER50-165	266.8	6.10kg								

刀柄系列 Tooling System

62032

BT/ER

M型立銑刀夾頭 Collet Chuck

刀柄系列
TOOLING SYSTEM



特點:

DIN ISO 15488

- ▶ M型刀桿採用小徑螺帽, 避免干涉。
- ▶ 刀具置入筒夾內孔, 必須超出筒夾內孔有效夾持長度, 避免不當鎖固, 造成損壞。
- ▶ 務必使用正確扳手來裝置, 不可任意改變, 避免不當鎖固, 造成損壞。
- ▶ 動平衡可以達到G6.3, 10000RPM。
- ▶ 平衡等級和轉速可以根據客戶的要求, 但需另行報價。

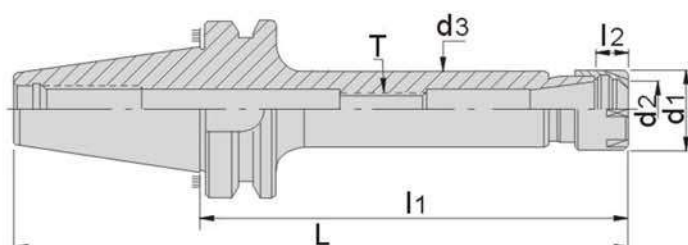

單位:mm

訂購編號 Order No.	型號-d2-l1 Model	L	l2	d1	d2 ER	d3	T	夾持範圍	重量 N.W.
62032-01	BT30xER11M-70	118.4	6.6	16	11	15	M6x1.0P	0.5~0.7	0.50kg
62032-02	BT30xER11M-100	148.4							0.60kg
62032-03	BT30xER11M-120	168.4							0.70kg
62032-04	BT30xER16M-70	118.4	10.6	22	16	21	M10x1.5P	0.5~10.0	0.55kg
62032-05	BT30xER16M-100	148.4							0.65kg
62032-06	BT30xER16M-120	168.4							0.75kg
62032-07	BT30xER20M-70	118.4	11.5	28	20	27	M12x1.75P	1.0~13.0	0.65kg
62032-08	BT30xER20M-100	148.4							0.70kg
62032-09	BT30xER20M-120	168.4							0.80kg
62032-10	BT30xER20M-150	198.4							1.00kg
62032-11	BT40xER11M-70	135.4	6.6	16	11	15	M6x1.0P	0.5~7.0	1.10kg
62032-12	BT40xER11M-100	165.4							1.20kg
62032-13	BT40xER11M-125	190.4							1.40kg
62032-14	BT40xER11M-150	215.4							1.50kg
62032-15	BT40xER16M-70	135.4	10.6	22	16	21	M10x1.5P	0.5~10.0	1.20kg
62032-16	BT40xER16M-100	165.4							1.30kg
62032-17	BT40xER16M-125	190.4							1.50kg
62032-18	BT40xER16M-150	215.4							1.60kg
62032-19	BT40xER20M-70	135.4	11.5	28	20	27	M12x1.75P	1.0~13.0	1.20kg
62032-20	BT40xER20M-100	165.4							1.55kg
62032-21	BT40xER20M-125	190.4							1.70kg
62032-22	BT40xER20M-150	215.4							1.80kg

62032
BT/ER
M型立銑刀夾頭 Collet Chuck

特點:
DIN ISO 15488

- ▶ M型刀桿採用小徑螺帽, 避免干涉。
- ▶ 刀具置入筒夾內孔, 必須超出筒夾內孔有效夾持長度, 避免不當鎖固, 造成損壞。
- ▶ 務必使用正確扳手來裝置, 不可任意改變, 避免不當鎖固, 造成損壞。
- ▶ 動平衡可以達到G6.3, 10000RPM。
- ▶ 平衡等級和轉速可以根據客戶的要求, 但需另行報價。

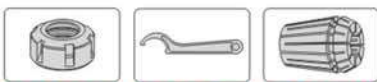
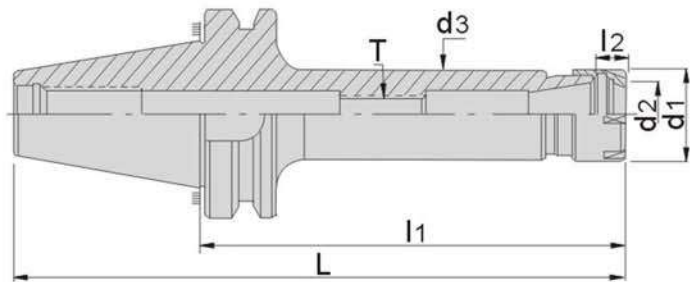
 刀柄系列
TOOLING SYSTEM

P.F81
P.F82
P.F72-74

單位:mm

訂購編號 Order No.	型號-d2-l1 Model	L	l2	d1	d2 ER	d3	T	夾持範圍	重量 N.W.
62032-23	BT50xER11M-70	171.8	6.6	16	11	15	M6x1.0P	0.5~0.7	3.8kg
62032-24	BT50xER11M-90	191.8							3.9kg
62032-25	BT50xER11M-105	206.8							4.0kg
62032-26	BT50xER11M-135	236.8							4.1kg
62032-27	BT50xER11M-165	266.8							4.2kg
62032-28	BT50xER16M-70	171.8	10.6	22	16	21	M10x1.5P	0.5~10.0	3.9kg
62032-29	BT50xER16M-90	191.8							4.0kg
62032-30	BT50xER16M-105	206.8							4.1kg
62032-31	BT50xER16M-135	236.8							4.2kg
62032-32	BT50xER16M-165	266.8							4.3kg
62032-33	BT50xER20M-90	191.8	11.5	28	20	27	M12x1.75P	1.0~13.0	4.1kg
62032-34	BT50xER20M-105	206.8							4.2kg
62032-35	BT50xER20M-135	236.8							4.4kg
62032-36	BT50xER20M-165	266.8							4.6kg

刀柄系列 Tooling System

62036

BT/SLN

側固式立銑刀夾頭 Side Lock End Mill Holder

刀柄系列
TOOLING SYSTEM



圖1



圖2



圖3

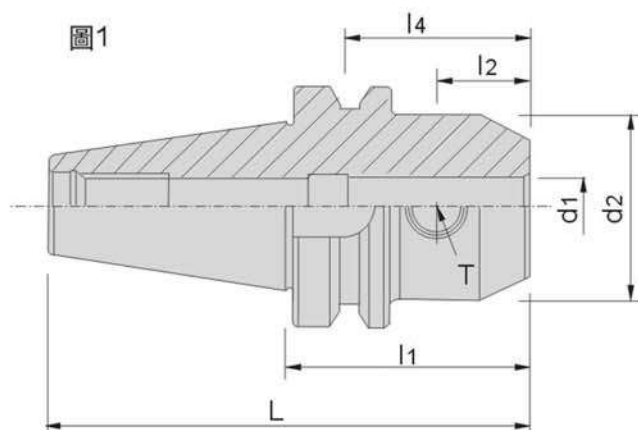

62036
BT/SLN
側固式立銑刀夾頭 Side Lock End Mill Holder

單位:mm

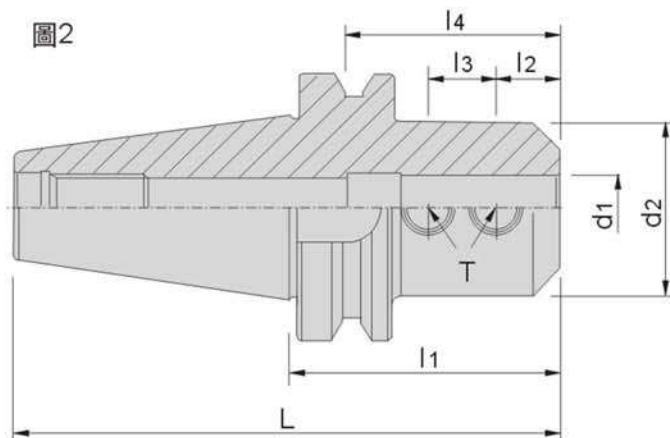
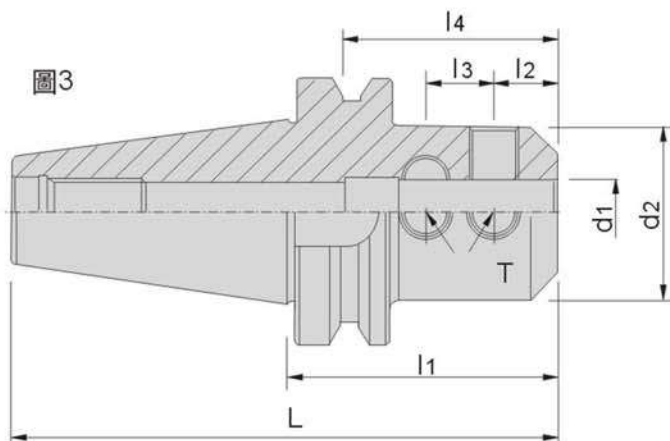
訂購編號 Order No.	型號 d1-l1 Model	L	l2	l3	l4	d2	T	圖示	重量 N.W.					
62036-01	BT30xSLN6-60	108.4	18	-	40	25	M6x1.0P	1	0.55kg					
62036-02	BT30xSLN8-60					28	M8x1.25P		0.60kg					
62036-03	BT30xSLN10-60		20		44	35	M10x1.5P		0.70kg					
62036-04	BT30xSLN12-60		22.5		49	42	M12x1.75P		0.75kg					
62036-05	BT30xSLN16-75	123.4	24	-	52	48	M14x2.0P	1	1.05kg					
62036-06	BT30xSLN20-75		25			54	52		M16x2.0P	1.10kg				
62036-07	BT30xSLN25-90	138.4	24		25	59	65		M18x2.0P	2	1.70kg			
62036-08	BT40xSLN6-50	115.4	18		-	40	25		M6x1.0P	1	1.10kg			
62036-09	BT40xSLN6-150	215.4		M8x1.25P				1.32kg						
62036-10	BT40xSLN8-50	115.4		28			44	35	M10x1.5P		1.10kg			
62036-11	BT40xSLN8-150	215.4							M12x1.75P		1.30kg			
62036-12	BT40xSLN10-63	128.4	20	-	49	42		M14x2.0P	1.25kg					
62036-13	BT40xSLN10-150	215.4						M16x2.0P	1.40kg					
62036-14	BT40xSLN12-63	128.4	22.5		52	48	M18x2.0P	1	1.30kg					
62036-15	BT40xSLN12-150	215.4							M20x2.0P	1.53kg				
62036-16	BT40xSLN16-63	128.4	24	54		50	M22x2.0P		1	1.40kg				
62036-17	BT40xSLN16-150	215.4								M24x2.0P	1.60kg			
62036-18	BT40xSLN18-63	128.4	25		59	65	M26x2.0P	1		1.65kg				
62036-19	BT40xSLN20-63									M28x2.0P	1.40kg			
62036-20	BT40xSLN25-100	165.4	24	25		59	65		M18x2.0P	2	2.50kg			
62036-21	BT40xSLN32-100			28		63	72		M20x2.0P		2.75kg			
62036-22	BT50xSLN6-63	164.8	18	-	40	25	M6x1.0P	1	3.80kg					
62036-23	BT50xSLN8-63					28	M8x1.25P		3.80kg					
62036-24	BT50xSLN10-63		20		44	35	M10x1.5P		3.00kg					
62036-25	BT50xSLN12-80		22.5		49	42	M12x1.75P		4.00kg					
62036-26	BT50xSLN16-80	181.8	24	-	52	48	M14x2.0P	1	4.40kg					
62036-27	BT50xSLN20-80		25			54	52		M16x2.0P	4.40kg				
62036-28	BT50xSLN25-100	201.8	24		25	59	65		M18x2.0P	2	5.10kg			
62036-29	BT50xSLN32-105	206.8			28	63	72		M20x2.0P		5.20kg			
62036-30	BT50xSLN40-115	216.8	30	32	73	90	M20x2.0P	2	6.60kg					
62036-31	BT50xSLN40-120	221.8							35	35	78	100	M24x2.0P	6.70kg
62036-32	BT50xSLN42-120													33.1
62036-33	BT50xSLN50-120								35	35	78	100	M24x2.0P	
62036-34	BT50xSLN50.8-120		33.1	28.58	78	95	M20x2.0P	3	6.80kg					
62036-35	BT50xSLN50.8-120	33.1	25.58	80	125	M16x2.0P	6.60kg							
62036-36	BT50xSLN63-120	33.1	25.58	80	125	M16x2.0P	6.60kg							

 刀柄系列
TOOLING SYSTEM

刀柄系列 Tooling System

62038

BT/SLN

側固式立銑刀夾頭 Side Lock End Mill Holder

刀柄系列
TOOLING SYSTEM



特點:

JIS

- ▶ 內孔公差: H5。
- ▶ 附有兩個側固螺絲。
- ▶ 中心冷卻(DIN 69871-AD)
- ▶ 動平衡可以達到G6.3, 8000RPM。
- ▶ 平衡等級和轉速可以根據客戶的要求, 但需另行報價。

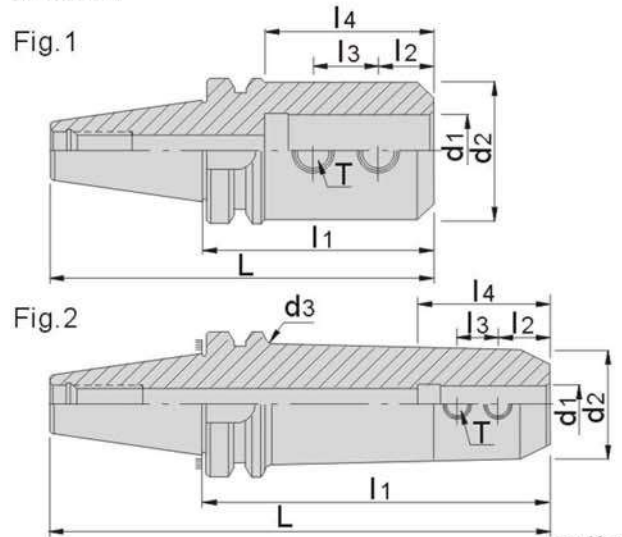

單位:mm

訂購編號 Order No.	型號 d1-l1 Model	L	l2	l3	l4	d2	d3	T	圖示	重量 N.W.
62038-01	BT40xSLN6-75J	140.4	12	10	45	25	-	M6x1.0P	1	1.30kg
62038-02	BT40xSLN6-150J	215.4	12	10	45	25	30		2	1.50kg
62038-03	BT40xSLN8-75J	140.4	14	12	45	28	-	M8x1.25P	1	1.30kg
62038-04	BT40xSLN8-150J	215.4	14	12	45	28	33		2	1.50kg
62038-05	BT40xSLN10-75J	140.4	15	14	49	35	-	M10x1.5P	1	1.30kg
62038-06	BT40xSLN10-150J	215.4	15	14	49	24	40		2	1.50kg
62038-07	BT40xSLN12-75J	140.4	20	16	54	42	-	M10x1.5P	1	1.50kg
62038-08	BT40xSLN12-150J	215.4	20	16	54	42	47		2	1.70kg
62038-09	BT40xSLN16-75J	140.4	22	18	57	48	-	M12x1.75P	1	1.50kg
62038-10	BT40xSLN16-150J	215.4	22	18	57	48	53		2	1.70kg
62038-11	BT40xSLN20-90J	155.4	25	20	65	50	-	M12x1.75P	1	1.60kg
62038-12	BT40xSLN20-150J	215.4	25	20	65	50	57		2	1.80kg
62038-13	BT40xSLN25-90J	155.4	24	25	68	50	-	M16x2.0P	1	2.50kg
62038-14	BT40xSLN32-100J	165.4	24	28	73	60	47		1	2.75kg
62038-15	BT50xSLN6-75J	176.8	12	10	45	25	47	M6x1.0P	1	3.90kg
62038-16	BT50xSLN8-75J	176.8	14	12	45	28	47		1	3.90kg
62038-17	BT50xSLN10-75J	176.8	15	14	49	35	47	M8x1.25P	1	3.90kg
62038-18	BT50xSLN12-90J	191.8	20	16	54	42	47		1	3.90kg
62038-19	BT50xSLN12-165J	266.8	20	16	54	42	47	M10x1.5P	2	5.00kg
62038-20	BT50xSLN16-90J	191.8	22	18	57	48	-		1	3.90kg
62038-21	BT50xSLN16-165J	266.8	22	18	57	48	53	M12x1.75P	2	5.00kg
62038-22	BT50xSLN20-90J	191.8	25	20	65	50	-		1	4.50kg
62038-23	BT50xSLN20-165J	266.8	25	20	65	50	57	M12x1.75P	2	6.00kg
62038-24	BT50xSLN20-210J	311.8	25	20	65	50	57		2	7.00kg

62038
BT/SLN
側固式立銑刀夾頭 Side Lock End Mill Holder

 TOOLING SYSTEM
刀柄系列

特點:
JIS

- ▶ 內孔公差: H5。
- ▶ 附有兩個側固螺絲。
- ▶ 中心冷却 (DIN 69871-AD)
- ▶ 動平衡可以達到 G6.3, 8000RPM。
- ▶ 平衡等級和轉速可以根據客戶的要求, 但需另行報價。

Fig.1

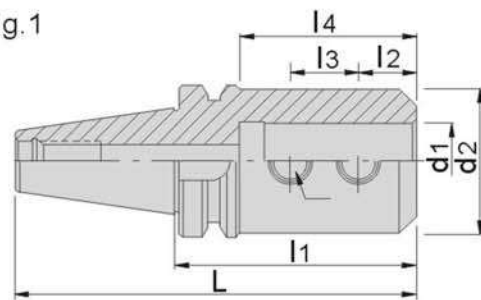
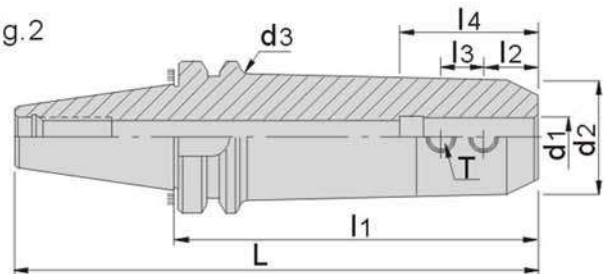

Fig.2



單位:mm

訂購編號 Order No.	型號 d1-l1 Model	L	l2	l3	l4	d2	d3	T	圖示	重量 N.W.
62038-25	BT50xSLN25-100J	201.8	24	25	68	50	-	M12x1.75P	1	4.5kg
62038-26	BT50xSLN25-165J	266.8	24	25	68	50	57		2	5.5kg
62038-27	BT50xSLN25-210J	311.8	24	25	68	50	57		2	6.0kg
62038-28	BT50xSLN25-250J	351.8	24	25	68	50	57		2	7.0kg
62038-29	BT50xSLN32-105J	206.8	24	28	73	60	-	M16x2.0P	1	4.8kg
62038-30	BT50xSLN32-165J	266.8	24	28	73	50	60		2	6.2kg
62038-31	BT50xSLN32-210J	311.8	24	28	73	50	60		2	6.3kg
62038-32	BT50xSLN32-250J	351.8	24	28	73	50	60		2	7.5kg
62038-33	BT50xSLN32-300J	401.8	24	28	73	60	65		2	8.0kg

刀柄系列 Tooling System

62040

BT/FMA

平面銑刀柄 Face Mill Arbor

刀柄系列
TOOLING SYSTEM



特點:

- ▶ D1公差: h6.
- ▶ 7/24錐度公差: AT3.
- ▶ 動平衡可以達到G6.3, 3000RPM.
- ▶ 平衡等級和轉速可以根據客戶的要求, 但需另行報價。

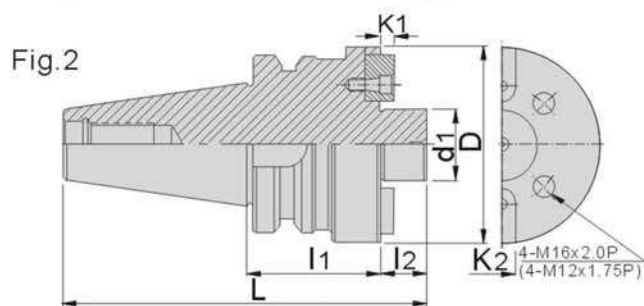
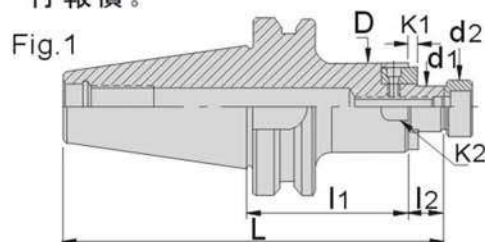

單位:mm

訂購編號 Order No.	型號 d1-l1 Model	L	l1	l2	D	d1	d2	K1	K2	圖示	重量 N.W.
62040-01	BT30xFMA25.4-45	113.4	45	20	50	25.4	31.5	4.52	9.52	1	1.10kg
62040-02	BT30xFMA25.4-60	128.4	60								1.30kg
62040-03	BT30xFMA31.75-45	115.4	45	22	60	31.75	41	6.7	12.7		1.35kg
62040-04	BT40xFMA25.4-45	130.4	45								1.80kg
62040-05	BT40xFMA25.4-60	145.4	60	20	50	25.4	31.5	4.52	9.52		2.00kg
62040-06	BT40xFMA25.4-90	175.4	90								2.60kg
62040-07	BT40xFMA25.4-105	190.4	105								2.70kg
62040-08	BT40xFMA31.75-45	132.4	45	22	60	31.75	41	6.7	12.7		2.00kg
62040-09	BT40xFMA31.75-75	162.4	75								2.70kg
62040-10	BT40xFMA31.75-90	177.4	90								2.90kg
62040-11	BT40xFMA38.10-60	150.4	60	25	75	38.1	44.5	8.87	15.87		2.80kg
62040-12	BT40xFMA50.80-60	161.4	60	36	98	50.8	65	9.75	19.05		4.00kg
62040-13	BT50xFMA25.4-45	166.8	45								4.40kg
62040-14	BT50xFMA25.4-90	211.8	90	20	50	25.4	31.5	4.52	9.52		5.10kg
62040-15	BT50xFMA25.4-150	271.8	150								6.10kg
62040-16	BT50xFMA31.75-45	168.8	45					6.2			4.50kg
62040-17	BT50xFMA31.75-75	198.8	75	22	60	31.75	41	6.7	12.7		5.30kg
62040-18	BT50xFMA31.75-105	228.8	105								5.70kg
62040-19	BT50xFMA38.10-45	171.8	45	25	80	38.1	44.5	8.87	15.87		4.80kg
62040-20	BT50xFMA38.10-75	210.8	75								6.00kg
62040-21	BT50xFMA50.80-45	182.8	45	36	98	50.8	65	9.75	19.05		5.70kg
62040-22	BT50xFMA50.80-75	212.8	75								6.80kg
62040-23	BT50xFMA47.62-75	208.8	75	32	128.75	47.62	-	12.5	25.4		2

62042
BT/FMA
平面銑刀柄(加長斜度柄) Face Mill Arbor-Extension Type

延長型

注:刀頭需另購

特點:

- ▶ d1公差: h6。
- ▶ 刀架通孔, 利於出水及抗震。
- ▶ 刀架頂部有一個錐形設計, 提高剛性。
- ▶ 動平衡可以達到G6.3, 3000RPM。
- ▶ 平衡等級和轉速可以根據客戶的要求, 但需另行報價。

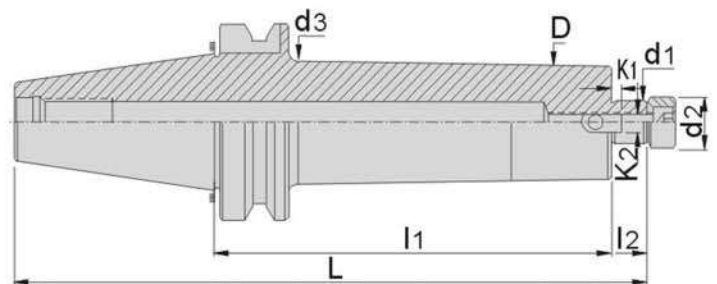

單位:mm

訂購編號 Order No.	型號 d1-l1 Model	L	l1	l2	D	d1	d2	d3	K1	K2	重量 N.W.
62042-01	BT50xFMA25.4-125BG	246.8	125	20	48	25.4	31.5	60	4.25	9.52	5.3kg
62042-02	BT50xFMA25.4-150BG	271.8	150								6.4kg
62042-03	BT50xFMA25.4-200BG	321.8	200								7.5kg
62042-04	BT50xFMA25.4-250BG	371.8	250								8.6kg
62042-05	BT50xFMA25.4-300BG	421.8	300								9.7kg
62042-06	BT50xFMA25.4-350BG	471.8	350								10.8kg
62042-07	BT50xFMA25.4-400BG	521.8	400								11.9kg
62042-08	BT50xFMA31.75-125BG	248.8	125	22	70	31.75	41	75	6.7	12.7	5.6kg
62042-09	BT50xFMA31.75-150BG	273.8	150								6.3kg
62042-10	BT50xFMA31.75-175BG	298.8	175								8.3kg
62042-11	BT50xFMA31.75-200BG	323.8	200								9.1kg
62042-12	BT50xFMA31.75-250BG	373.8	250								10.6kg
62042-13	BT50xFMA31.75-300BG	423.8	300								12.1kg
62042-14	BT50xFMA31.75-350BG	473.8	350								13.6kg

刀柄系列 Tooling System

62044

BT/FMB

平面銑刀柄 Face Mill Arbor

刀柄系列
TOOLING SYSTEM



特點:

- ▶ d1公差: h6。
- ▶ 7/24錐度公差: AT3。
- ▶ 動平衡可以達到G6.3, 3000RPM。
- ▶ 平衡等級和轉速可以根據客戶的要求, 但需另行報價。

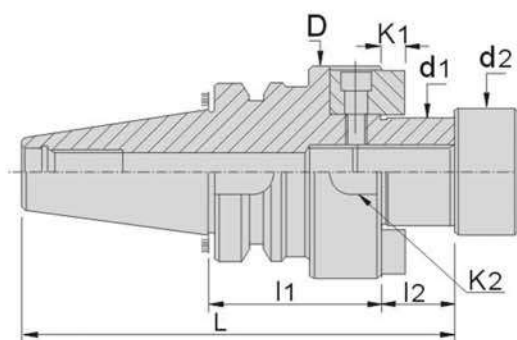

單位:mm

訂購編號 Order No.	型號 d1-l1 Model	L	l1	l2	D	d1	d2	K1	K2	重量 N.W.
62044-01	BT30xFMB22-45	115.4	45	19	48	22	26	4.8	10	0.85kg
62044-02	BT30xFMB22-60	127.4	60							1.25kg
62044-03	BT30xFMB27-45	113.4	45	20	60	27	31.5	5.8	12	1.20kg
62044-04	BT30xFMB27-60	128.4	60							1.35kg
62044-05	BT30xFMB32-45	115.4	45	22	78	32	41	6.8	14	1.35kg
62044-06	BT40xFMB22-45	129.4	45							1.45kg
62044-07	BT40xFMB22-60	144.4	60	19	48	22	26	4.8	10	1.70kg
62044-08	BT40xFMB22-100	184.4	100							2.20kg
62044-09	BT40xFMB27-45	130.4	45	20	60	27	31.5	5.8	12	1.60kg
62044-10	BT40xFMB27-60	145.4	60							2.00kg
62044-11	BT40xFMB27-90	175.4	90	22	78	32	41	6.8	14	2.30kg
62044-12	BT40xFMB27-105	190.4	105							2.50kg
62044-13	BT40xFMB32-45	132.4	45	22	78	32	41	6.8	14	1.75kg
62044-14	BT40xFMB32-60	147.4	60							2.10kg
62044-15	BT40xFMB40-60	150.4	60	25	80	40	48	8.3	16	2.80kg

特點:

- ▶ d1公差: h6.
- ▶ 7/24錐度公差: AT3.
- ▶ 動平衡可以達到G6.3, 3000RPM.
- ▶ 平衡等級和轉速可以根據客戶的要求, 但需另行報價。

Fig.1

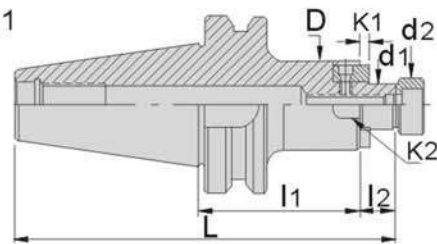
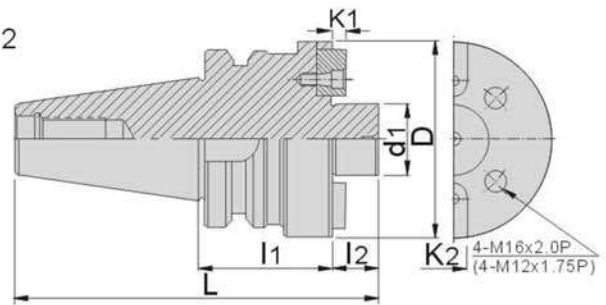

Fig.2



單位: mm

訂購編號 Order No.	型號 d1-l1 Model	L	l1	l2	D	d1	d2	K1	K2	圖示	重量 N.W.
62044-16	BT50xFMB22-45	165.8	45	19	48	22	26	4.8	10	1	4.5kg
62044-17	BT50xFMB22-90	210.8	90								5.1kg
62044-18	BT50xFMB22-150	270.8	150								6.8kg
62044-19	BT50xFMB22-200	320.8	200								7.0kg
62044-20	BT50xFMB22-250	370.8	250								8.0kg
62044-21	BT50xFMB27-50	171.8	50	20	60	27	31.5	5.8	12		4.6kg
62044-22	BT50xFMB27-90	211.8	90								5.4kg
62044-23	BT50xFMB27-150	271.8	150								7.5kg
62044-24	BT50xFMB27-200	321.8	200								9.5kg
62044-25	BT50xFMB27-250	371.8	250								11.0kg
62044-26	BT50xFMB32-50	173.8	50	22	78	32	41	6.8	14		5.7kg
62044-27	BT50xFMB32-90	213.8	90							5.8kg	
62044-28	BT50xFMB40-50	176.8	50							25	89
62044-29	BT50xFMB40-90	216.8	90	6.0kg							
62044-30	BT50xFMB40-105	231.8	105	7.2kg							
62044-31	BT50xFS40F-75	202.8	75	26	110	40	-	8.3	16	2	6.0kg
62044-32	BT50xFS60F-75	201.8	75	25	138	60	-	12.5	25.4		8.5kg

刀柄系列 Tooling System

62046

BT/FMB

平面銑刀柄(加長斜度柄) Face Mill Arbor-Extension Type

刀柄系列
TOOLING SYSTEM



延長型

注:刀頭需另購

特點:

- ▲ d1公差: h6。
- ▲ 刀架通孔, 利於出水及抗震。
- ▲ 刀架頂部有一個錐形設計, 提高剛性。
- ▲ 動平衡可以達到G6.3, 3000RPM。
- ▲ 平衡等級和轉速可以根據客戶的要求, 但需另行報價。

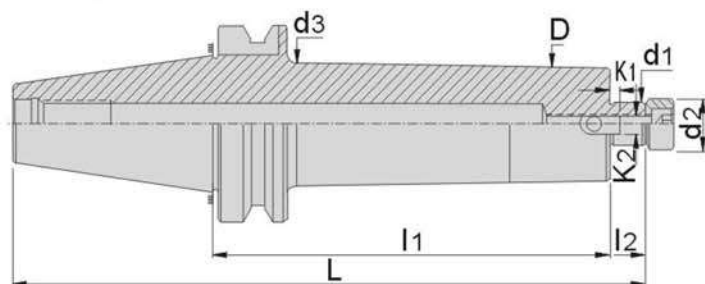

單位:mm

訂購編號 Order No.	型號 d1-l1 Model	L	l1	l2	D	d1	d2	d3	K1	K2	重量 N.W.
62046-01	BT40xFMB22-150BG	233.4	150	18	48	22	31.75	51	4.25	9.52	3.1kg
62046-02	BT40xFMB22-200BG	283.4	200								4.0kg
62046-03	BT40xFMB22-250BG	333.4	250								4.9kg
62046-04	BT50xFMB22-150BG	271.8	150	20	58	22	31.75	62.5	4.25	9.52	6.8kg
62046-05	BT50xFMB22-200BG	321.8	200								8.4kg
62046-06	BT50xFMB22-250BG	371.8	250								9.4kg
62046-07	BT50xFMB22-300BG	421.8	300								10.4kg
62046-08	BT50xFMB22-350BG	471.8	350								11.4kg
62046-09	BT50xFMB22-400BG	521.8	400								12.4kg
62046-10	BT50xFMB22-450BG	571.8	450								13.4kg
62046-11	BT50xFMB22-500BG	621.8	500								14.4kg

62048
BT/MTA
斜柄鑽頭套筒 Morse Taper Adapter

特點:
DIN 228-B

- ▲ 高精確的工作流程,即使使用加長型鑽頭,同心度仍然在0.015mm。
- ▲ 適用於扁尾型莫氏錐柄鑽頭。

Fig.1

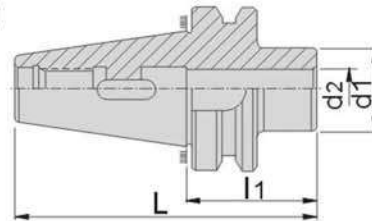
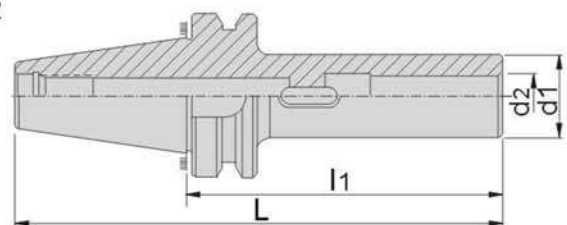

Fig.2



單位:mm

訂購編號 Order No.	型號-MTA-l1 Model	L	l1	d1	d2	圖示	重量 N.W.
62048-01	BT30xMTA1-45	93.4	45	25	12.065	1	0.55kg
62048-02	BT30xMTA1-105	153.4	105			2	0.80kg
62048-03	BT30xMTA2-60	108.4	60	32	17.78	1	0.60kg
62048-04	BT30xMTA2-120	168.4	120			2	0.90kg
62048-05	BT30xMTA3-80	128.4	80	40	23.825	1	0.80kg
62048-06	BT40xMTA1-45	110.4	45	25	12.065	1	1.05kg
62048-07	BT40xMTA1-120	185.4	120			2	1.40kg
62048-08	BT40xMTA2-50	115.4	50	32	17.78	1	1.10kg
62048-09	BT40xMTA2-120	185.4	120			2	1.80kg
62048-10	BT40xMTA3-70	135.4	70	40	23.825	1	1.20kg
62048-11	BT40xMTA3-135	200.4	135			2	1.90kg
62048-12	BT40xMTA4-95	160.4	95	48	31.267	1	1.40kg
62048-13	BT40xMTA4-165	230.4	165			2	2.50kg
62048-14	BT50xMTA1-45	146.8	45	25	12.065	1	3.80kg
62048-15	BT50xMTA1-120	221.8	120			2	4.30kg
62048-16	BT50xMTA1-180	281.8	180			2	5.00kg
62048-17	BT50xMTA2-60	161.8	60	32	17.78	1	4.00kg
62048-18	BT50xMTA2-135	236.8	135			2	4.70kg
62048-19	BT50xMTA2-180	281.8	180			2	5.00kg
62048-20	BT50xMTA3-65	166.8	65	40	23.825	1	3.90kg
62048-21	BT50xMTA3-150	251.8	150			2	5.00kg
62048-22	BT50xMTA3-180	281.8	180			2	5.50kg
62048-23	BT50xMTA4-95	196.8	95	48	31.267	1	4.20kg
62048-24	BT50xMTA4-180	281.8	180			2	5.50kg
62048-25	BT50xMTA5-105	206.8	105	63	44.399	1	4.30kg

刀柄系列 Tooling System

62050

BT/MTB

斜柄鑽頭套筒 Morse Taper Adapter

刀柄系列
TOOLING SYSTEM



特點:

DIN 6364

- ▲ 高精確的工作流程,即使使用加長型鑽頭,同心度仍然在0.015mm。
- ▲ 適用於後拉式斜柄鑽頭。

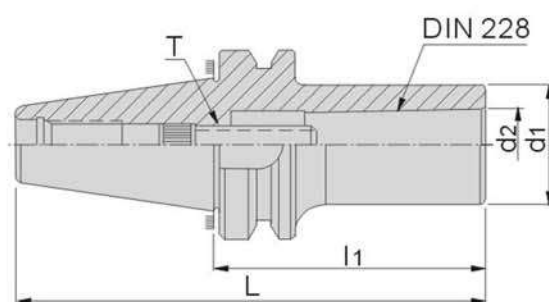

訂購時,請確認“T”部螺絲規格為公製或英製。

單位:mm

訂購編號 Order No.	型號-MTB-I1 Model	L	l1	d1	d2	T	重量 N.W.
62050-01	BT30xMTB1-45	93.4	45	25	12.065	M6(M6*1.0P) A01(1/4"-20)	0.55kg
62050-02	BT30xMTB2-60	108.4	60	32	17.78	M10(M10*1.5P) A02(3/8"-16)	0.60kg
62050-03	BT40xMTB1-45	110.4	45	25	12.065	M6(M6*1.0P) A01(1/4"-20)	1.05kg
62050-04	BT40xMTB2-45	110.4	45	32	17.78	M10(M10*1.5P) A02(3/8"-16)	1.85kg
62050-05	BT40xMTB2-185	250.4	185	32	17.78	M10(M10*1.5P) A02(3/8"-16)	2.20kg
62050-06	BT40xMTB3-75	140.4	75	40	23.825	M12(M12*1.75P) A04(1/2"-12)	1.30kg
62050-07	BT40xMTB3-90	155.4	90				1.40kg
62050-08	BT40xMTB3-120	185.4	120				1.80kg
62050-09	BT40xMTB3-180	245.4	180	48	31.267	M16(M16*2.0P) A06(5/8"-11)	2.40kg
62050-10	BT40xMTB4-100	165.4	100				1.60kg
62050-11	BT40xMTB4-120	185.4	120				1.80kg
62050-12	BT40xMTB4-180	245.4	180	25	12.065	M6(M6*1.0P) A01(1/4"-20)	2.60kg
62050-13	BT50xMTB1-45	146.8	45				3.80kg
62050-14	BT50xMTB2-45	146.8	45				32
62050-15	BT50xMTB3-60	161.8	60	40	23.825	M12(M12*1.75P) A04(1/2"-12)	3.90kg
62050-16	BT50xMTB4-75	176.8	75	48	31.267	M16(M16*2.0P) A06(5/8"-11)	4.20kg
62050-17	BT50xMTB5-120	221.8	120	63	44.399	M24(M24*3.0P) A07(1"-8)	4.30kg

62052
DAT/C
直筒式強力型刀桿 Multi-Lock Mill Chuck

特點:

- ▶ 開槽: 刀桿內孔開槽(分割6槽), 以防止滑動, 並加大夾持力。
- ▶ 滾針軸承: 採用兩線裝置, 確保滑動至針錐面時滾動摩擦及脫落減至最小。
- ▶ 防水及防塵, 夾緊後端面接觸。
- ▶ 此設計結構不會過分緊固而損傷夾頭。
- ▶ 密封式結構, 以消除污垢和碎片損害夾頭。
- ▶ 動平衡可以達到G6.3, 8000RPM。
- ▶ 平衡等級和轉速可以根據客戶的要求, 但需另行報價。

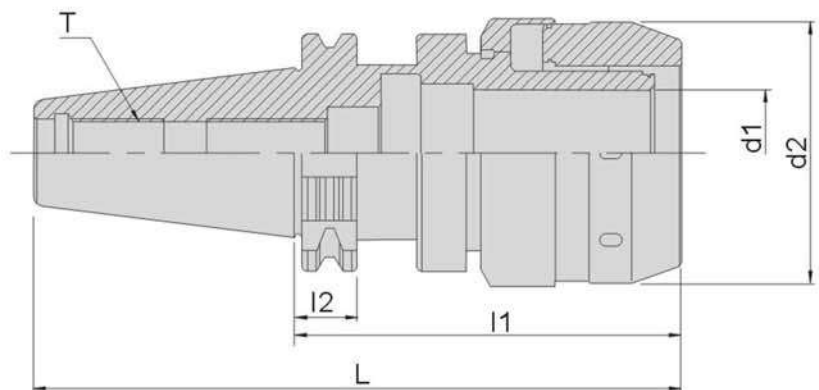
 刀柄系列
TOOLING SYSTEM

P.F82
P.F67

單位:mm

訂購編號 Order No.	型號-d1-l1 Model	L	l1	l2	d1	d2	T
62052-01	DAT30-C20-80	127.8	80	19.1	20	55	M12x1.75
62052-02	DAT40-C20-80	148.4	80	19.1	32	68.5	
62052-03	DAT40-C20-100	168.4	100	19.1	32	68.5	
62052-04	DAT40-C20-135	203.4	135	19.1	32	68.5	
62052-05	DAT40-C25-80	148.4	80	19.1	32	68.5	M16x2.0
62052-06	DAT40-C25-100	168.4	100	19.1	32	68.5	
62052-07	DAT40-C32-90	158.4	90	19.1	32	68.5	
62052-08	DAT40-C32-105	173.4	105	19.1	32	68.5	
62052-09	DAT40-C32-135	203.4	135	19.1	32	68.5	M24x3.0
62052-10	DAT50-C32-110	211.75	110	19.1	32	68.5	
62052-11	DAT50-C32-135	236.75	135	19.1	32	68.5	
62052-12	DAT50-C32-165	266.75	165	19.1	32	68.5	
62052-13	DAT50-C32-200	301.75	200	19.1	32	68.5	
62052-14	DAT50-C42-110	211.75	110	19.1	42	92	

刀柄系列 Tooling System

62055

CAT-HC

直筒式強力型刀桿 Multi-Lock Milling Chuck

刀柄系列
TOOLING SYSTEM



特點:

- ▲ 防水及防塵, 夾緊後端面接觸。
- ▲ 此設計結構不會過分緊固而損傷夾頭。
- ▲ 密封式結構, 以消除污垢和碎片損害夾頭。
- ▲ 動平衡可以達到G6.3, 8000RPM。
- ▲ 平衡等級和轉速可以根據客戶的要求, 但需另行報價。

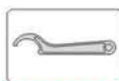
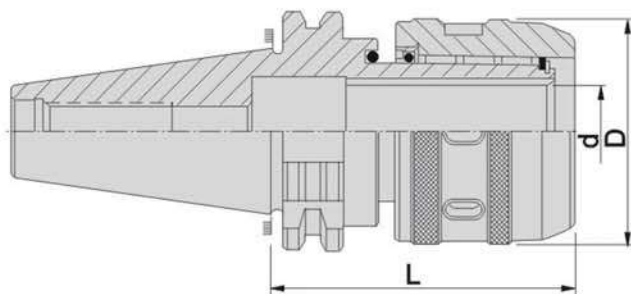

P.F82

P.F67

訂購編號 Order No.	型號 Model	d	D	L	Collet	重量 N.W.
62055-05	CAT40-HC3/4"-4"	3/4"	50	4"	C3/4"	2.3kg
62055-06	CAT40-HC1"-4"	1"	59	4"	C1"	2.7kg
62055-07	CAT40-HC1-1/4"-4"	1.25"	70	4"	C1.25"	3.3kg
62055-08	CAT50-HC3/4"-4"	3/4"	50	4"	C3/4"	5.6kg
62055-10	CAT50-HC1"-4"	1"	59	4"	C1"	6.0kg
62055-11	CAT50-HC1-1/4"-4"	1.25"	70	4"	C1.25"	6.6kg

62056
DAT/ER
立銑刀夾頭 Collet Chuck

特點:
DIN ISO 15488

- ▶ 螺紋經精密磨削。
- ▶ ER16, ER20緊固螺帽為外六角螺母。
- ▶ 可以額外購買強力螺母。
- ▶ 動平衡可以達到G6.3, 10000RPM。
- ▶ 平衡等級和轉速可以根據客戶的要求,但需另行報價。

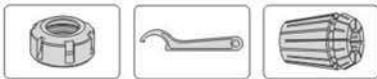
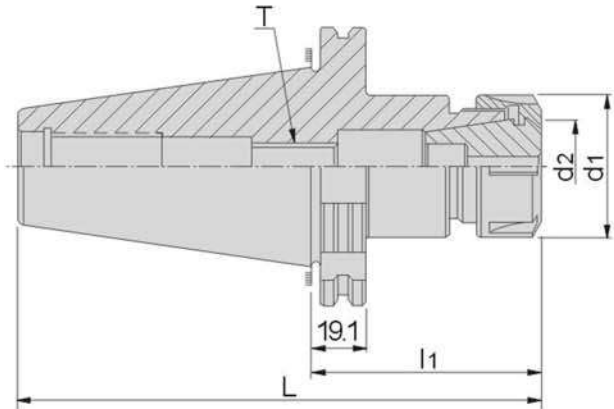
P.F81 P.F82 P.F72-76

單位:mm

訂購編號 Order No.	型號-d2-l1 Model	L	d1	d2	T	夾持範圍	重量 N.W.
62056-01	DAT30xER11A-80	127.8	19	11	M6x1.0P	0.5~7.0	0.60kg
62056-02	DAT30xER16A-63	110.8	28	16	M10x1.5P	0.5~10.0	0.70kg
62056-03	DAT30xER16A-120	167.8					0.85kg
62056-04	DAT30xER20A-63	110.8	34	20	M12x1.75P	1.0~13	0.80kg
62056-05	DAT30xER20A-120	167.8					1.05kg
62056-06	DAT30xER25-63	110.8	42	25	M16x2.0P	1.0~16	0.85kg
62056-07	DAT30xER32-63	110.8	50	32		2.0~20	0.90kg

刀柄系列 Tooling System

62058

DAT/ER

立銑刀夾頭 Collet Chuck

刀柄系列
TOOLING SYSTEM



特點:

DIN ISO 15488

- ▶ 可以夾直柄和工具。
- ▶ ER16, ER20緊固螺帽為外六角螺母。
- ▶ ER25, ER32, ER40, ER50附有一個標準螺母,可以額外購買強力螺母。
- ▶ 動平衡可以達到G6.3, 10000RPM。
- ▶ 平衡等級和轉速可以根據客戶的要求,但需另行報價。

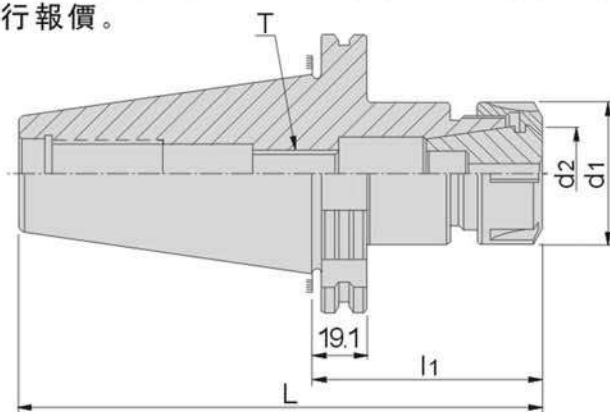

單位:mm

訂購編號 Order No.	型號-d2-l1 Model	L	d1	d2	T	夾持範圍	重量 N.W.
62058-01	DAT40xER11A-80	148.4	19	11	M6x1.0P	0.5~7.0	1.05kg
62058-02	DAT40xER11A-125	193.4					1.15kg
62058-03	DAT40xER16A-70	138.4	28	16	M10x1.5P	0.5~10.0	1.30kg
62058-04	DAT40xER16A-100	168.4					1.40kg
62058-05	DAT40xER16A-125	193.4					1.60kg
62058-06	DAT40xER16A-150	218.4					1.65kg
62058-07	DAT40xER16A-180	248.4					1.85kg
62058-08	DAT40xER20A-70	138.4					34
62058-09	DAT40xER20A-100	168.4	1.50kg				
62058-10	DAT40xER20A-135	203.4	1.95kg				
62058-11	DAT40xER20A-160	228.4	2.20kg				
62058-12	DAT40xER25-70	138.4	42	25	M16x2.0P	1.0~16.0	1.60kg
62058-13	DAT40xER25-100	168.4					1.85kg
62058-14	DAT40xER25-150	218.4					2.25kg
62058-15	DAT40xER25-180	248.4					2.45kg
62058-16	DAT40xER25-200	268.4					2.55kg
62058-17	DAT40xER32-70	138.4					50
62058-18	DAT40xER32-100	168.4	2.00kg				
62058-19	DAT40xER32-135	203.4	2.15kg				
62058-20	DAT40xER32-150	218.4	2.65kg				
62058-21	DAT40xER40-70	138.4	63	40	M20x2.0P	3.0~26.0	1.50kg
62058-22	DAT40xER40-100	168.4					2.00kg
62058-23	DAT40xER40-135	218.4					2.30kg
62058-24	DAT40xER50-100	168.4					78

62060
DAT/ER
立銑刀夾頭 Collet Chuck

特點:
DIN ISO 15488

- ▶ 可以夾直柄和工具。
- ▶ ER16, ER20緊固螺帽為外六角螺母。
- ▶ ER25, ER32, ER40, ER50附有一個標準螺母,可以額外購買強力螺母。
- ▶ 動平衡可以達到G6.3, 10000RPM。
- ▶ 平衡等級和轉速可以根據客戶的要求,但需另行報價。

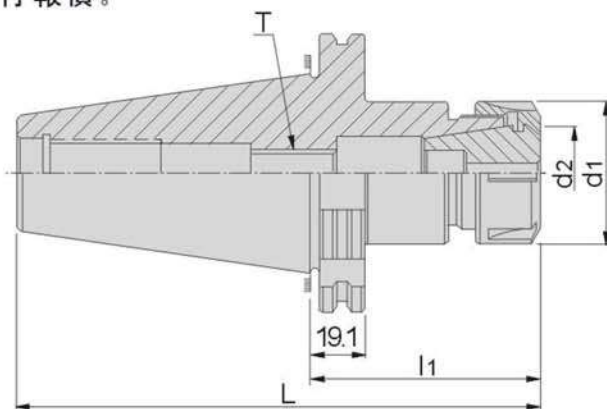

單位:mm

P.F81
P.F82
P.F72-78

訂購編號 Order No.	型號-d2-l1 Model	L	d1	d2	T	夾持範圍	重量 N.W.
62060-01	DAT50xER16A-100	201.75	28	16	M10x1.5P	0.5~10.0	3.20kg
62060-02	DAT50xER16A-135	236.75					4.30kg
62060-03	DAT50xER16A-160	261.75					4.50kg
62060-04	DAT50xER16A-180	281.75					4.80kg
62060-05	DAT50xER20A-100	201.75	34	20	M12x1.75P	1.0~13.0	3.40kg
62060-06	DAT50xER20A-135	236.75					3.60kg
62060-07	DAT50xER20A-160	261.75					3.80kg
62060-08	DAT50xER25-70	171.75	42	25	M16x2.0P	1.0~16.0	3.40kg
62060-09	DAT50xER25-100	201.75					4.15kg
62060-10	DAT50xER25-150	251.75					4.50kg
62060-11	DAT50xER25-200	301.75					4.70kg
62060-12	DAT50xER32-80	181.75	50	32	M20x2.0P	2.0~20.0	3.60kg
62060-13	DAT50xER32-120	221.75					4.60kg
62060-14	DAT50xER32-160	261.75					4.75kg
62060-15	DAT50xER32-200	301.75					4.90kg
62060-16	DAT50xER40-80	181.75	63	40	M20x2.0P	3.0~26.0	3.65kg
62060-17	DAT50xER40-120	221.75					4.80kg
62060-18	DAT50xER40-160	261.75					5.20kg
62060-19	DAT50xER40-200	301.75					5.40kg
62060-20	DAT50xER50-80	181.75	78	50	M24x2.0P	5.0~34.0	4.85kg
62060-21	DAT50xER50-120	221.75					5.45kg
62060-22	DAT50xER50-160	261.75					5.55kg
62060-23	DAT50xER50-200	301.75					5.70kg

刀柄系列 Tooling System

62062

DAT/ER

M型立銑刀夾頭 Collet Chuck

刀柄系列
TOOLING SYSTEM



特點:

M型

- ▲ M型刀桿採用小徑螺帽,避免干涉。
- ▲ 刀具置入筒夾內孔,必須超出筒夾內孔有效夾持長度,避免不當鎖固,造成損壞。
- ▲ 務必使用正確扳手來裝置,不可任意改變,避免不當鎖固,造成損壞。
- ▲ 動平衡可以達到G6.3, 10000RPM。
- ▲ 平衡等級和轉速可以根據客戶的要求,但需另行報價。

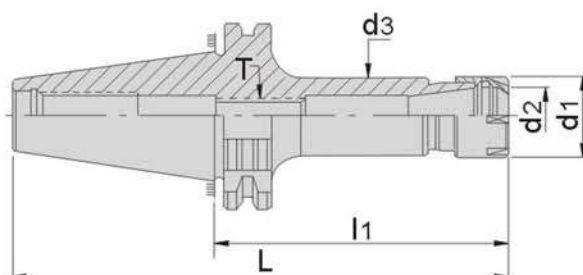

P.F81

P.F82

P.F72~74

單位:mm

訂購編號 Order No.	型號-d2-l1 Model	L	d1	d2 ER	d3	T	夾持範圍	重量 N.W.
62062-01	DAT30xER11M-70	117.8	16	11	15	M6x1.0P	0.5~7.0	0.50kg
62062-02	DAT30xER11M-100	147.8						0.60kg
62062-03	DAT30xER11M-120	167.8						0.70kg
62062-04	DAT30xER16M-70	117.8	22	16	21	M10x1.5P	0.5~10.0	0.55kg
62062-05	DAT30xER16M-100	147.8						0.65kg
62062-06	DAT30xER16M-120	167.8						0.75kg
62062-07	DAT30xER20M-100	147.8	28	20	27	M12x1.75P	1.0~13.0	0.70kg
62062-08	DAT30xER20M-120	167.8						0.80kg
62062-09	DAT30xER20M-150	197.8						1.00kg
62062-10	DAT40xER11M-70	138.4	16	11	15	M6x1.0P	0.5~7.0	1.10kg
62062-11	DAT40xER11M-100	168.4						1.20kg
62062-12	DAT40xER11M-125	193.4						1.40kg
62062-13	DAT40xER11M-150	218.4						1.50kg
62062-14	DAT40xER16M-70	138.4	22	16	21	M10x1.5P	0.5~10.0	1.20kg
62062-15	DAT40xER16M-100	168.4						1.30kg
62062-16	DAT40xER16M-125	193.4						1.50kg
62062-17	DAT40xER16M-150	218.4						1.60kg
62062-18	DAT40xER20M-70	138.4	28	20	27	M12x1.75P	1.0~13.0	1.20kg
62062-19	DAT40xER20M-100	168.4						1.55kg
62062-20	DAT40xER20M-125	193.4						1.70kg
62062-21	DAT40xER20M-150	218.4						1.80kg

62064
DAT/ER
M型立銑刀夾頭 Collet Chuck

特點:
M型

- ▶ M型刀桿採用小徑螺帽, 避免干涉。
- ▶ 刀具置入筒夾內孔, 必須超出筒夾內孔有效夾持長度, 避免不當鎖固, 造成損壞。
- ▶ 務必使用正確扳手來裝置, 不可任意改變, 避免不當鎖固, 造成損壞。
- ▶ 動平衡可以達到G6.3, 10000RPM。
- ▶ 平衡等級和轉速可以根據客戶的要求, 但需另行報價。

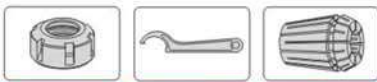
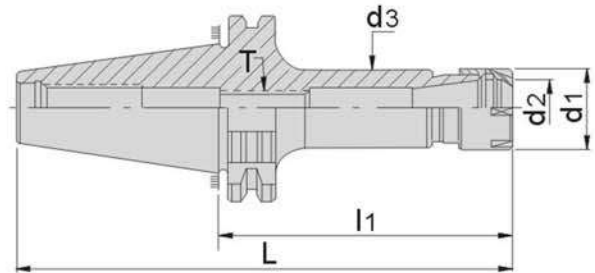
P.F81 P.F82 P.F72~74

單位:mm

訂購編號 Order No.	型號-d2-l1 Model	L	d1	d2 ER	d3	T	夾持範圍	重量 N.W.
62064-01	DAT50xER11M-70	171.75	16	11	15	M6x1.0P	0.5~7.0	3.8kg
62064-02	DAT50xER11M-90	191.75						3.9kg
62064-03	DAT50xER11M-105	206.75						4.0kg
62064-04	DAT50xER11M-135	236.75						4.1kg
62064-05	DAT50xER11M-165	266.75						4.2kg
62064-06	DAT50xER16M-70	171.75	22	16	21	M10x1.5P	0.5~10.0	3.9kg
62064-07	DAT50xER16M-90	191.75						4.0kg
62064-08	DAT50xER16M-105	206.75						4.1kg
62064-09	DAT50xER16M-135	236.75						4.2kg
62064-10	DAT50xER16M-165	266.75						4.3kg
62064-11	DAT50xER20M-90	191.75	28	20	27	M12x1.75P	1.0~13.0	4.1kg
62064-12	DAT50xER20M-105	206.75						4.2kg
62064-13	DAT50xER20M-135	236.75						4.4kg
62064-14	DAT50xER20M-165	266.75						4.6kg

刀柄系列 Tooling System

62066

DAT/SLN

側固式立銑刀柄 Lock End Mill Holder

刀柄系列
TOOLING SYSTEM



特點:

DIN 1835

- ▶ 內孔公差: H5。
- ▶ 柄徑的動平衡必須符合DIN-1835-B, 及其配套工具也符合本標準。
- ▶ 直徑允許公差h6~h7內附有兩個側固螺絲。
- ▶ 動平衡可以達到G6.3, 8000RPM。
- ▶ 平衡等級和轉速可以根據客戶的要求, 但需另行報價。

Fig.1

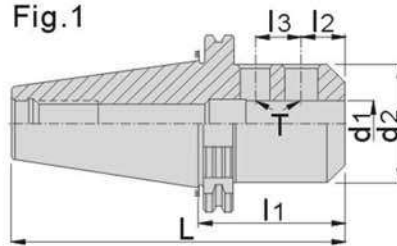
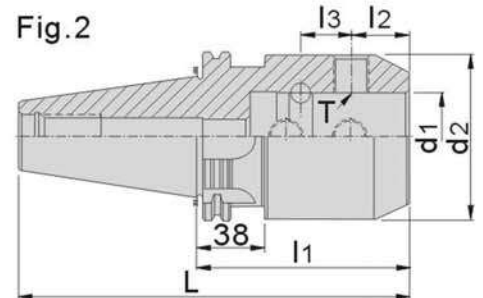

Fig.2



單位:mm

訂購編號 Order No.	型號-d1-l1 Model	L	l2	l3	d2	T	圖示	重量 N.W.		
62066-01	DAT30xSLN6-50	97.8	18		25	M6x1.0P	1	0.73kg		
62066-02	DAT30xSLN8-50	97.8			28	M8x1.25P		0.80kg		
62066-03	DAT30xSLN10-50	97.8			20	35		M10x1.5P	0.90kg	
62066-04	DAT30xSLN12-50	97.8			22.5	42		M12x1.75P	0.90kg	
62066-05	DAT30xSLN16-63	110.8			24	48		M14x2.0P	1.10kg	
62066-06	DAT40xSLN6-50	118.4	-		25	M6x1.0P		0.85kg		
62066-07	DAT40xSLN8-50	118.4			18	28		M8x1.25P	1.00kg	
62066-08	DAT40xSLN10-50	118.4			20	35		M10x1.5P	1.10kg	
62066-09	DAT40xSLN12-50	118.4			22.5	42		M12x1.75P	1.15kg	
62066-10	DAT40xSLN16-63	131.4			24	48		M14x2.0P	1.40kg	
62066-11	DAT40xSLN20-63	131.4			25	52		M16x2.0P	1.30kg	
62066-12	DAT40xSLN25-100	168.4			24	25		65	M18x2.0P	2.40kg
62066-13	DAT40xSLN32-100	168.4				28		72	M20x2.0P	2.70kg
62066-14	DAT50xSLN6-63	164.75			18			25	M6x1.0P	3.10kg
62066-15	DAT50xSLN8-63	164.75	28	M8x1.25P				3.10kg		
62066-16	DAT50xSLN10-63	164.75	20	35				M10x1.5P	3.30kg	
62066-17	DAT50xSLN12-63	164.75	22.5	42				M12x1.75P	3.50kg	
62066-18	DAT50xSLN16-63	164.75	24	48				M14x2.0P	3.45kg	
62066-19	DAT50xSLN20-63	164.75	25	52				M16x2.0P	3.50kg	
62066-20	DAT50xSLN25-80	181.75	24	25				65	M18x2.0P	4.20kg
62066-21	DAT50xSLN32-100	201.75						72	M20x2.0P	5.00kg
62066-22	DAT50xSLN40-100	201.75	30	32				90	M20x2.0P	5.60kg
62066-23	DAT50xSLN42-100	201.75			M20x2.0P	5.70kg				
62066-24	DAT50xSLN50-125	226.75	35	35	100	M24x2.0P		5.90kg		
62066-25	DAT50xSLN50.8-120	221.75	33.1	28.58	95	M20x2.0P		2	5.80kg	
62066-26	DAT50xSLN63-150	250.75	40	40	125	M20x2.0P		1	6.20kg	
62066-27	DAT50xSLN63-150	250.75		24	125	M16x2.0P			6.20kg	

特點:
FMB型

- ▶ d1公差: h6。
- ▶ 7/24錐度公差: AT3。
- ▶ 動平衡可以達到G6.3, 3000RPM。
- ▶ 平衡等級和轉速可以根據客戶的要求, 但需另行報價。

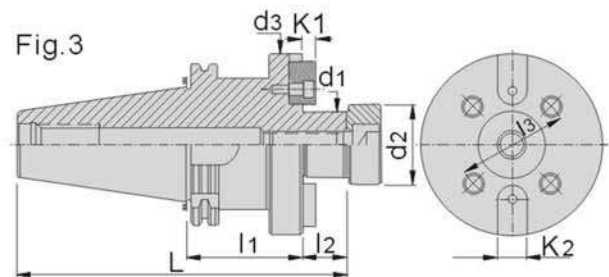
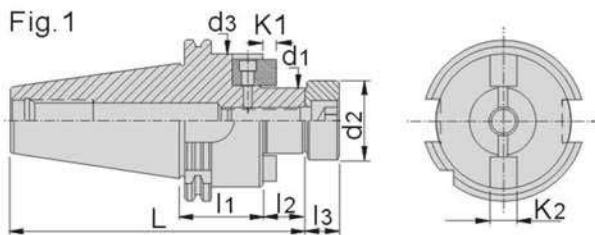
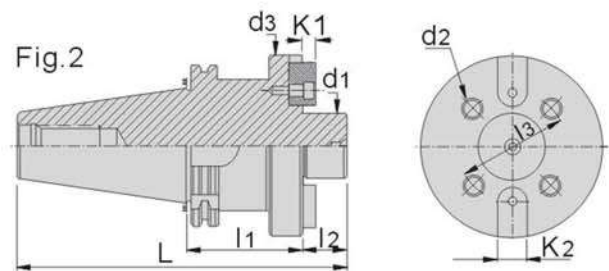

單位:mm

訂購編號 Order No.	型號-d1-l1 Model	L	l ₂	l ₃	d ₂	d ₃	K ₁	K ₂	圖示	重量 N.W.
62068-01	DAT30xFMB22-35	101.8	19	14	26	45	4.8	10	1	1.00kg
62068-02	DAT30xFMB27-55	122.8	20	16	31.5	58	5.8	12		1.05kg
62068-03	DAT40xFMB22-35	122.4	19	14	26	48	4.8	10		1.20kg
62068-04	DAT40xFMB27-60	148.4	20	16	31.5	58	5.8	12		1.80kg
62068-05	DAT40xFMB32-60	150.4	22	16	41	66	6.8	14		2.30kg
62068-06	DAT40xFMB40-60	153.4	25	20.5	48	80	8.3	16		2.80kg
62068-07	DAT50xFMB22-35	155.75	19	14	26	48	4.8	10		3.40kg
62068-08	DAT50xFMB27-35	156.75	20	16	31.5	58	5.8	12		3.50kg
62068-09	DAT50xFMB32-35	158.75	22	16	41	66	6.8	14		3.70kg
62068-10	DAT50xFMB40-50	189.75	25	20.5	48	80	8.3	16		4.70kg
62068-11	DAT50xFMB50-60	191.75	30	25	68	95	9.7	19	5.80kg	
62068-12	DAT40xFMB40F-60	158.4	30	66.7	M12	89	8.3	15.9	2	2.90kg
62068-13	DAT50xFMB40F-60	201.75	30	66.7	M12	89	8.3	15.9		5.50kg
62068-14	DAT50xFMB40F-70	211.75	40	101.6	M16	129	12.5	25.4	3	5.70kg
62068-15	DAT40xFS40-60	154.4	26	66.7	50	110	8.3	16		3.20kg
62068-16	DAT50xFS40-70	197.75	26	66.7	50	110	8.3	16	2	5.70kg
62068-17	DAT50xFS60-70	196.75	25	101.6	M16	140	12.5	25.4		5.50kg

刀柄系列 Tooling System

62070

DAT/MTA

斜柄鑽頭套筒 Morse Taper Adapter

刀柄系列
TOOLING SYSTEM



特點:

DIN 228-B
DIN 6383

- ▲ 高精確的工作流程,即使使用加長型鑽頭,同心度仍然在0.015mm。
- ▲ 適用於扁尾型莫氏錐柄鑽頭。

Fig.1

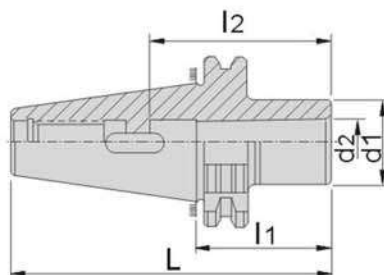
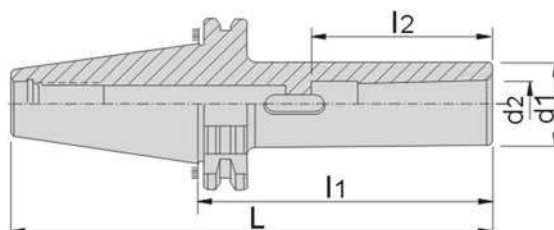

Fig.2



單位:mm

訂購編號 Order No.	型號-I1 Model	L	l2	d1	d2	重量 N.W.
62070-01	DAT30xMTA1-50	97.8	56	25	12.065	0.55kg
62070-02	DAT30xMTA2-60	117.8	67	32	17.78	0.80kg
62070-03	DAT30xMTA3-75	122.8	84	40	23.825	1.00kg
62070-04	DAT40xMTA1-50	118.4	56	25	12.065	1.20kg
62070-05	DAT40xMTA2-50	118.4	67	32	17.78	1.00kg
62070-06	DAT40xMTA3-70	138.4	84	40	23.825	1.10kg
62070-07	DAT40xMTA4-95	163.4	107	48	31.267	1.35kg
62070-08	DAT50xMTA1-45	146.75	56	25	12.065	3.00kg
62070-09	DAT50xMTA2-60	161.75	67	32	17.78	3.10kg
62070-10	DAT50xMTA3-65	166.75	84	40	23.825	3.20kg
62070-11	DAT50xMTA4-95	196.75	107	48	31.267	3.40kg
62070-12	DAT50xMTA5-105	206.75	133	63	44.399	3.60kg

62073
HSK-HC
直式筒夾 Multi-Lock Milling Chuck

特點:
DIN 69893-1

- ▶ 防水及防塵, 夾緊后端面接觸。
- ▶ 此設計結構不會過分緊固而損傷夾頭。
- ▶ 密封式結構, 以消除污垢和碎片損害夾頭。
- ▶ 刀具置入筒夾內孔, 必須超出筒夾內孔有效夾持長度, 避免不當鎖固, 造成損壞。
- ▶ 務必使用正確扳手來裝置, 不可任意改變, 避免不當鎖固, 造成損壞。
- ▶ 動平衡可以達到G6.3, 8000RPM。
- ▶ 平衡等級和轉速可以根據客戶的要求, 但需另行報價。

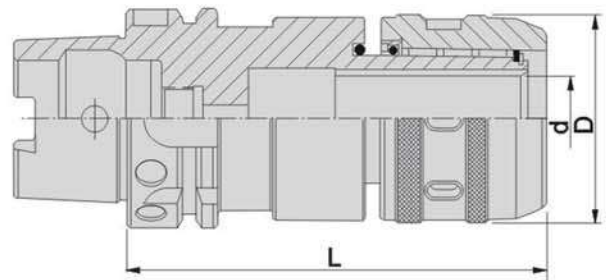
P.F67 P.F67

單位:mm

訂購編號 Order No.	型號-d-L Model	d	D	L	Capacity	重量 N.W.
62073-02	HSK63A-HC20-85	20	50	85	4-20	1.8kg
62073-04	HSK63A-HC32-110	32	70	110	3-25	3.2kg

62073-06	HSK100A-HC20-105	20	50	105	4-20	2.9kg
62073-08	HSK100A-HC32-105	32	70	105	3-25	5.6kg

刀柄系列 Tooling System

62074

HSK/ER

立銑刀夾頭 Collet Chuck

刀柄系列
TOOLING SYSTEM



DIN 69893-1
DIN ISO 15488

特點:

- ▶ 刀桿的旋轉都經平衡機檢測。
- ▶ 刀桿的旋轉動平衡可以達到G2.5, 25000RPM。
- ▶ 可以夾持任何一種直徑刀具和工具。
- ▶ 平衡等級和轉速可以根據客戶的要求,但需另行報價。

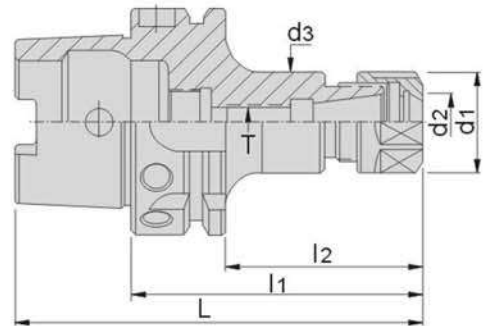

單位:mm

訂購編號 Order No.	型號-d2-l1 Model	L	l2	d1	d2	d3 MAX.	T	重量 N.W.
62074-01	HSK40AxER20A-80	100	60	34	20	32	M10x1.5P	0.35kg
62074-02	HSK40AxER25-80			42	25			0.40kg
62074-03	HSK50AxER16A-80	105	54	28	16	M10x1.5P	0.50kg	
62074-04	HSK50AxER16A-100	125	74				0.55kg	
62074-05	HSK50AxER16A-120	145	94	34	20	M12x1.75P	0.70kg	
62074-06	HSK50AxER20A-80	105	54				0.60kg	
62074-07	HSK50AxER20A-100	125	74	42	25	M16x2.0P	0.65kg	
62074-08	HSK50AxER20A-120	145	94				0.70kg	
62074-09	HSK50AxER25-80	105	54	50	32	M16x2.0P	0.70kg	
62074-10	HSK50AxER25-100	125	74				0.80kg	
62074-11	HSK50AxER25-135	160	109	53	20	M12x1.75P	0.90kg	
62074-12	HSK50AxER32-100	125	74				1.35kg	
62074-13	HSK50AxER32-135	160	109	42	25	M16x2.0P	1.50kg	
62074-14	HSK50AxER32-160	185	134				1.70kg	
62074-15	HSK63AxER16A-80	112	54	28	16	M10x1.5P	1.50kg	
62074-16	HSK63AxER16A-100	132	74				1.55kg	
62074-17	HSK63AxER16A-120	152	94	34	20	M12x1.75P	1.70kg	
62074-18	HSK63AxER16A-160	192	134				1.90kg	
62074-19	HSK63AxER20A-80	112	54	53	20	M12x1.75P	1.60kg	
62074-20	HSK63AxER20A-100	132	74				1.70kg	
62074-21	HSK63AxER20A-120	152	94	42	25	M16x2.0P	1.80kg	
62074-22	HSK63AxER20A-160	192	134				2.00kg	
62074-23	HSK63AxER25-80	112	54	42	25	M16x2.0P	1.70kg	
62074-24	HSK63AxER25-100	132	74				1.80kg	
62074-25	HSK63AxER25-120	152	94	182	124	M16x2.0P	2.00kg	
62074-26	HSK63AxER25-150	182	124				2.30kg	

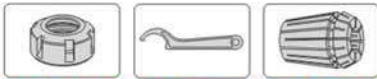
62076
HSK/ER
立銑刀夾頭 Collet Chuck

P.F81
P.F82
P.F74~75
特點:
**DIN 69893-1
DIN ISO 15488**

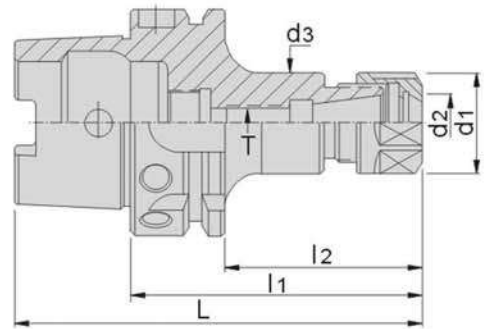
- ▶ 刀桿的旋轉都經平衡機檢測。
- ▶ 刀桿的旋轉動平衡可以達到G2.5, 25000RPM。
- ▶ 可以夾持任何一種直徑刀具和工具。
- ▶ 平衡等級和轉速可以根據客戶的要求,但需另行報價。



單位:mm

訂購編號 Order No.	型號-d2-l1 Model	L	l2	d1	d2 ER	d3 MAX.	T	重量 N.W.	
62076-01	HSK63AxER32-80	112	54	50	32	53	-	2.50kg	
62076-02	HSK63AxER32-100	132	74				M16x2.0P	2.55kg	
62076-03	HSK63AxER32-145	177	119				M16x2.0P	2.70kg	
62076-04	HSK63AxER32-160	192	134				M16x2.0P	3.10kg	
62076-05	HSK63AxER40-80	112	54	63	40		-	2.65kg	
62076-06	HSK63AxER40-100	132	74				M20x2.0P	2.70kg	
62076-07	HSK63AxER40-120	152	94				M20x2.0P	2.77kg	
62076-08	HSK63AxER40-150	182	124				M20x2.0P	2.95kg	
62076-09	HSK63AxER40-170	202	144	78	50		M24x2.0P	3.10kg	
62076-10	HSK63AxER50-120	152	94				M24x2.0P	3.50kg	
62076-11	HSK100AxER16A-80	130	51			28	16	M10x1.5P	2.90kg
62076-12	HSK100AxER16A-100	150	71					M10x1.5P	2.95kg
62076-13	HSK100AxER16A-160	210	131	M10x1.5P	3.45kg				
62076-14	HSK100AxER20A-80	130	51	34	20			M12x1.75P	2.90kg
62076-15	HSK100AxER20A-100	150	71			M12x1.75P	3.00kg		
62076-16	HSK100AxER20A-160	210	131			M12x1.75P	3.30kg		
62076-17	HSK100AxER25-100	150	71			42	25	M16x2.0P	3.00kg
62076-18	HSK100AxER25-130	180	101	M16x2.0P	3.20kg				
62076-19	HSK100AxER32-100	150	71	50	32			M16x2.0P	3.15kg
62076-20	HSK100AxER32-135	185	106					M16x2.0P	3.35kg
62076-21	HSK100AxER32-150	200	121			M16x2.0P	3.50kg		
62076-22	HSK100AxER40-80	130	51			63	40	M20x2.0P	3.30kg
62076-23	HSK100AxER40-120	170	91	M20x2.0P	3.38kg				
62076-24	HSK100AxER40-175	225	146	M20x2.0P	4.20kg				
62076-25	HSK100AxER50-100	150	71	78	50			M24x2.0P	4.50kg
62076-26	HSK100AxER50-120	170	91			5.00kg			

刀柄系列 Tooling System

62078

HSK/SLN

側固式立銑刀柄 Lock End Mill Holder

DIN 69893-1
DIN 1835-B

特點:

- ▶ 內孔公差: H5。
- ▶ 柄徑的動平衡必須符合DIN-1835-B, 柄徑允許公差h6~h7內。
- ▶ 都經平衡機檢測。
- ▶ 動平衡可以達到G6.3, 8000RPM。
- ▶ 平衡等級和轉速可以根據客戶的要求, 但需另行報價。

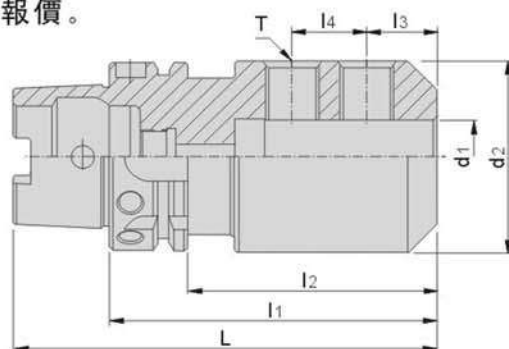

單位: mm

訂購編號 Order No.	型號-d1-l1 Model	L	l2	l3	l4	d2	T	重量 N.W.	
62078-01	HSK50AxSLN6-65	90	39	18		25	M6x1.0P	0.7kg	
62078-02	HSK50AxSLN8-65			18		28	M8x1.25P	0.8kg	
62078-03	HSK50AxSLN10-65			20		35	M10x1.5P	0.8kg	
62078-04	HSK50AxSLN12-80	105	54	22.5		42	M12x1.75P	1.2kg	
62078-05	HSK50AxSLN14-80			22.5		44		1.3kg	
62078-06	HSK50AxSLN16-80			24		48	M14x2.0P	1.3kg	
62078-07	HSK50AxSLN18-80			24		50		1.4kg	
62078-08	HSK50AxSLN20-80			25		52	M16x2.0P	1.5kg	
62078-09	HSK63AxSLN6-65	97	39	18	-	25	M6x1.0P	0.9kg	
62078-10	HSK63AxSLN8-65			18	28	M8x1.25P	1.0kg		
62078-11	HSK63AxSLN10-65			20	35	M10x1.5P	1.0kg		
62078-12	HSK63AxSLN12-80	112	54	22.5		42	M12x1.75P	1.7kg	
62078-13	HSK63AxSLN14-80			22.5		44		1.7kg	
62078-14	HSK63AxSLN16-80			24		48	M14x2.0P	1.7kg	
62078-15	HSK63AxSLN18-80			24		50		1.8kg	
62078-16	HSK63AxSLN20-80			25		52	M16x2.0P	1.8kg	
62078-17	HSK63AxSLN25-110	142	84	24	25	65	M18x2.0P	2.5kg	
62078-18	HSK63AxSLN32-110			24	28	72	M20x2.0P	2.7kg	
62078-19	HSK100AxSLN6-80	130	51	18		25	M6x1.0P	3.0kg	
62078-20	HSK100AxSLN8-80			18		28	M8x1.25P	3.2kg	
62078-21	HSK100AxSLN10-80			20		35	M10x1.5P	3.4kg	
62078-22	HSK100AxSLN12-80			22.5		42	M12x1.75P	3.4kg	
62078-23	HSK100AxSLN14-80			22.5		44		3.5kg	
62078-24	HSK100AxSLN16-100	150	71	24		48	M14x2.0P	3.8kg	
62078-25	HSK100AxSLN18-100			24		50	M16x2.0P	3.8kg	
62078-26	HSK100AxSLN20-100			25		52		3.9kg	
62078-27	HSK100AxSLN25-100			24		25	65	M18x2.0P	4.0kg
62078-28	HSK100AxSLN32-100			24		28	72	M20x2.0P	4.1kg
62078-29	HSK100AxSLN40-120	170	30	32	90	4.4kg			

62080

HSK/SLN

側固式立銑刀柄 Lock End Mill Holder

特點:

DIN 69893-1

- ▶ 內孔公差: H5。
- ▶ 都經平衡機檢測。
- ▶ 動平衡可以達到G6.3, 8000RPM。
- ▶ 平衡等級和轉速可以根據客戶的要求, 但需另行報價。

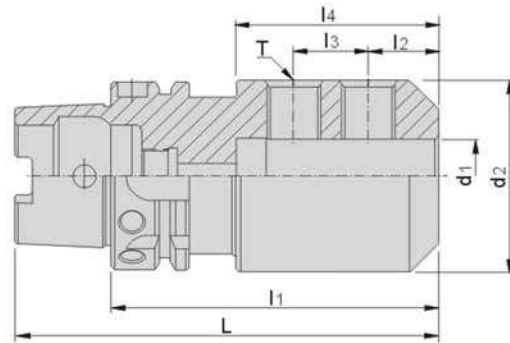

單位: inch

訂購編號 Order No.	型號-d1-l1 Model	L	l2	l3	l4	d2	T	重量 N.W.
62080-01	HSK40AxSLN1/4"-2.5"	3.287	0.63		1.38	0.78	1/4-28	0.31kg
62080-02	HSK40AxSLN3/8"-2.5"	3.287	0.75		1.535	1	3/8-24	0.42kg
62080-03	HSK40AxSLN1/2"-2.75"	3.537	0.875		1.732	1.25	7/16-20	0.57kg
62080-04	HSK40AxSLN5/8"-3"	3.787	0.937		1.85	1.5	1/2-20	0.69kg
62080-05	HSK63AxSLN1/4"-3"	4.26	0.63	-	1.38	0.78	1/4-28	0.76kg
62080-06	HSK63AxSLN3/8"-3"	4.26	0.75		1.535	1	3/8-24	0.88kg
62080-07	HSK63AxSLN1/2"-3"	4.26	0.875		1.732	1.25	7/16-20	1.13kg
62080-08	HSK63AxSLN5/8"-3.75"	5	0.937		1.85	1.5	1/2-20	1.26kg
62080-09	HSK63AxSLN3/4"-3.75"	5	1		1.929	1.75	5/8-18	1.33kg
62080-10	HSK63AxSLN1"-3.75"	5	1.125	1	2.559	2	3/4-16	2.30kg
62080-11	HSK63AxSLN1-1/4"-4.25"	5.51	1.125		2.559	2.5		2.52kg
62080-12	HSK100AxSLN1/4"-3"	4.97	0.63		1.38	0.78	1/4-28	2.16kg
62080-13	HSK100AxSLN3/8"-3"	4.97	0.75		1.535	1	3/8-24	2.31kg
62080-14	HSK100AxSLN1/2"-3.25"	5.219	0.875	-	1.732	1.25	7/16-20	2.45kg
62080-15	HSK100AxSLN5/8"-3.75"	5.719	0.937		1.85	1.5	1/2-20	2.84kg
62080-16	HSK100AxSLN3/4"-3.75"	5.719	1		1.929	1.75	5/8-18	2.95kg
62080-17	HSK100AxSLN1"-4.25"	6.219	1.125		2.559	2	3/4-16	3.46kg
62080-18	HSK100AxSLN1-1/4"-4.25"	6.219	1.125	1	2.559	2.5		3.73kg
62080-19	HSK100AxSLN1-1/2"-4.5"	6.469	1.125		2.756	2.5		5.51kg
62080-20	HSK100AxSLN2"-5.5"	7.469	1.335	1.41	3.347	3.75	1-14	6.37kg

刀柄系列 Tooling System

62082

HSK/SLN

側固式立銑刀柄 Lock End Mill Holder

DIN 69893-1
DIN 1835-E

特點:

- ▶ 內孔公差: H5。
- ▶ 柄徑的動平衡必須符合DIN-1835-B, 柄徑允許公差h6~h7內。
- ▶ 側固螺絲角度 2° 。
- ▶ 都經平衡機檢測。
- ▶ 動平衡可以達到G6.3, 8000RPM。
- ▶ 平衡等級和轉速可以根據客戶的要求, 但需另行報價。

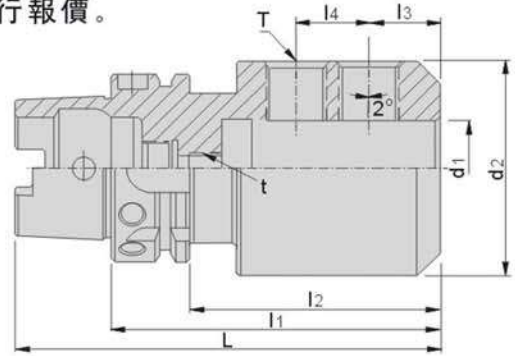

單位:mm

訂購編號 Order No.	型號-d1-l1 Model	L	l2	l3	l4	d2	t	T	重量 N.W.
62082-01	HSK50AxSLNB6-80	105	54	18		25	M5	M6x1.0P	0.8kg
62082-02	HSK50AxSLNB8-80			18		28	M6	M8x1.25P	0.9kg
62082-03	HSK50AxSLNB10-80			20		35	M8	M10x1.5P	0.9kg
62082-04	HSK50AxSLNB12-90	115	64	22.5		42	M10	M12x1.75P	1.3kg
62082-05	HSK50AxSLNB14-90			22.5		44			M12
62082-06	HSK50AxSLNB16-90			24		48	M12	M14x2.0P	1.4kg
62082-07	HSK50AxSLNB18-90			24		50	M16	M16x2.0P	1.6kg
62082-08	HSK50AxSLNB20-100	125	74	25		52	M16	M16x2.0P	1.7kg
62082-09	HSK63AxSLNB6-80	112	54	18	-	25	M5	M6x1.0P	1.0kg
62082-10	HSK63AxSLNB8-80			18		28	M6	M8x1.25P	1.1kg
62082-11	HSK63AxSLNB10-80			20		35	M8	M10x1.5P	1.1kg
62082-12	HSK63AxSLNB12-90	122	64	22.5		42	M10	M12x1.75P	2.0kg
62082-13	HSK63AxSLNB14-90			22.5		44			M12
62082-14	HSK63AxSLNB16-100			24		48	M12	M14x2.0P	2.0kg
62082-15	HSK63AxSLNB18-100			24		50	M16	M16x2.0P	2.1kg
62082-16	HSK63AxSLNB20-100	132	74	25		52	M16	M16x2.0P	2.1kg
62082-17	HSK63AxSLNB25-110			24		65	M20	M18x2.0P	2.6kg
62082-18	HSK63AxSLNB32-110			24		72	M20	M20x2.0P	2.8kg
62082-19	HSK100AxSLNB6-90	140	61	18		25	M5	M6x1.0P	3.4kg
62082-20	HSK100AxSLNB8-90			18		28	M6	M8x1.25P	3.5kg
62082-21	HSK100AxSLNB10-90			20		35	M8	M10x1.5P	3.8kg
62082-22	HSK100AxSLNB12-100	150	71	22.5		42	M10	M12x1.75P	3.8kg
62082-23	HSK100AxSLNB14-100			22.5		44			M12
62082-24	HSK100AxSLNB16-100			24		48	M12	M14x2.0P	4.0kg
62082-25	HSK100AxSLNB18-100			24		50	M16	M16x2.0P	4.0kg
62082-26	HSK100AxSLNB20-110	160	81	25		52	M16	M16x2.0P	4.2kg
62082-27	HSK100AxSLNB25-120	170	91	24	22	65	M20	M18x2.0P	4.4kg
62082-28	HSK100AxSLNB32-120			24	24	72		M20x2.0P	4.5kg
62082-29	HSK100AxSLNB40-120			30	32	90		M20x2.0P	5.0kg

62084
HSK/FMB
平面銑刀柄 Face Mill Arbor

特點:
DIN 69893-1

- ▶ d1公差: h6.
- ▶ 動平衡可以達到G6.3, 3000RPM.
- ▶ 平衡等級和轉速可以根據客戶的要求, 但需另行報價。

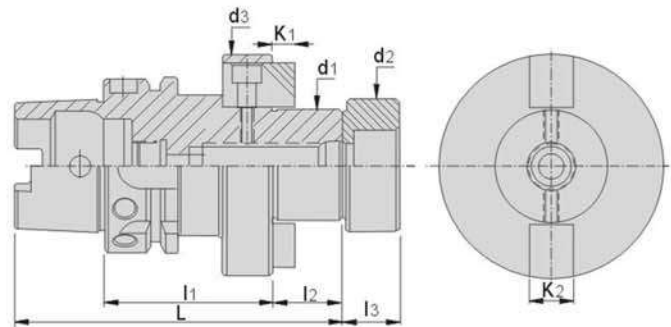

單位:mm

訂購編號 Order No.	型號-d1-l1 Model	L	l2	l3	d2	d3	K1	K2	重量 N.W.
62084-01	HSK40AxFMB16-50	87	17	-	-	40	3.8	8	0.7kg
62084-02	HSK40AxFMB22-60	99	19	14	26	50	4.8	10	0.8kg
62084-03	HSK40AxFMB27-60	101	21	16	31.5	60	5.8	12	1.0kg
62084-04	HSK40AxFMB32-60	104	24	16	41	78	6.8	14	1.1kg
62084-05	HSK50AxFMB16-50	92	17	-	-	40	3.8	8	1.1kg
62084-06	HSK50AxFMB22-60	104	19	14	26	50	4.8	10	1.2kg
62084-07	HSK50AxFMB27-60	106	21	16	31.5	60	5.8	12	1.3kg
62084-08	HSK50AxFMB32-60	109	24	16	41	78	6.8	14	1.5kg
62084-09	HSK63AxFMB16-50	99	17	-	-	40	3.8	8	1.2kg
62084-10	HSK63AxFMB22-50	101	19	14	26	50	4.8	10	1.3kg
62084-11	HSK63AxFMB27-60	113	21	16	31.5	60	5.8	12	1.5kg
62084-12	HSK63AxFMB32-60	116	24	16	41	78	6.8	14	1.6kg
62084-13	HSK63AxFMB40-60	119	25	20.5	48	89	8.3	16	2.1kg
62084-14	HSK100AxFMB22-50	119	19	14	26	50	4.8	10	2.7kg
62084-15	HSK100AxFMB27-50	121	21	16	31.5	60	5.8	12	2.9kg
62084-16	HSK100AxFMB32-50	124	24	16	41	78	6.8	14	3.0kg
62084-17	HSK100AxFMB40-60	137	25	20.5	48	89	8.3	16	4.0kg
62084-18	HSK100AxFMB50-70	150	30	25	68	120	9.7	19	5.1kg
62084-19	HSK100AxFMB60-70	160	40	-	-	129	12.5	25.4	5.5kg

刀柄系列 Tooling System

62086

HSK/MTA

斜柄鑽頭套筒 Morse Taper Adapter



刀柄系列
TOOLING SYSTEM



特點:

DIN 69893-1

- ▲ 刀桿的旋轉都經平衡機檢測。
- ▲ 真圓度: 0.005mm。
- ▲ MTA=TANG型=DIN 228-B。
- ▲ 適用扁尾型莫氏錐柄鑽頭。

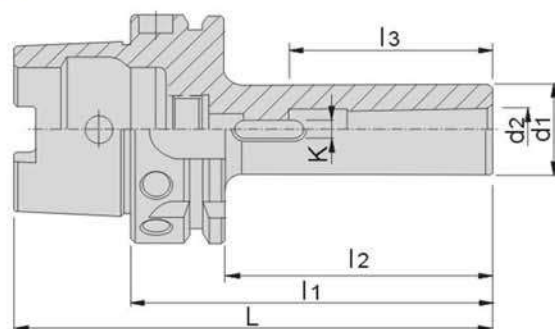

單位:mm

訂購編號 Order No.	型號-MTA-I1 Model	L	l ₂	l ₃	d ₁	d ₂	K	重量 N.W.
62086-01	HSK50AxMTA1-100	125	74	56	25	12.065	5.2	1.5kg
62086-02	HSK50AxMTA2-120	145	94	67	32	17.78	6.3	1.8kg
62086-03	HSK50AxMTA3-140	165	114	84	40	23.825	7.9	1.9kg
62086-04	HSK63AxMTA1-100	132	74	56	25	12.065	5.2	1.9kg
62086-05	HSK63AxMTA2-120	152	94	67	32	17.78	6.3	2.0kg
62086-06	HSK63AxMTA3-140	172	114	84	40	23.825	7.9	2.2kg
62086-07	HSK63AxMTA4-160	192	134	107	48	31.267	11.9	2.5kg
62086-08	HSK100AxMTA1-110	160	81	56	25	12.065	5.2	3.4kg
62086-09	HSK100AxMTA2-120	170	91	67	32	17.78	6.3	3.8kg
62086-10	HSK100AxMTA3-150	200	121	84	40	23.825	7.9	4.0kg
62086-11	HSK100AxMTA4-170	220	141	107	48	31.267	11.9	4.6kg
62086-12	HSK100AxMTA5-200	250	171	135	63	44.399	15.9	5.2kg

62090
NT/ER
銑刀夾頭柄 Collet Holder

特點:
DIN ISO 15488

- ▶ 鋼材: SCM-21。
- ▶ 主體的末端, 有一個塑料環保護主軸免受損害。
- ▶ 可以單獨購買, 每只鎖有一個夾緊螺母, 但不附扳手。

 刀柄系列
TOOLING SYSTEM

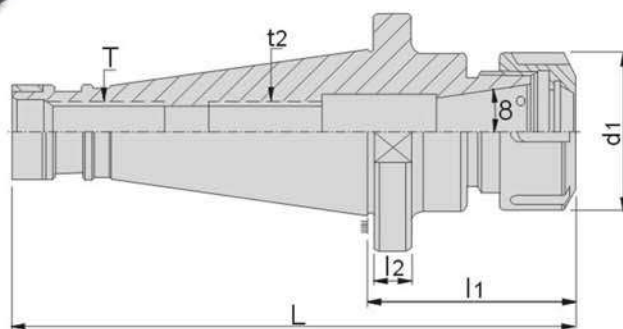
P.F81
P.F82
P.F73~78

訂購時, 請確認拉桿螺絲規格為公製或英製。

單位:mm

訂購編號 Order No.	型號-ER-I1 Model	L	l ₂	d ₁	t ₂	T DRAW BAR	重量 N.W.
62090-01	NT30xER16A-45	111.4	8	28	M10x1.5P	M12(M12*1.75P) A04(1/2"-12)	0.50kg
62090-02	NT30xER20A-45	113.4		34	M12x1.75P		0.60kg
62090-03	NT30xER25-55	123.4		42	M16x2.0P		0.65kg
62090-04	NT30xER32-60	128.4		50			0.80kg
62090-05	NT30xER40-75	143.4		63			0.90kg
62090-06	NT40xER16A-45	138.4	10	28	M10x1.5P	M16(M16*2.0P) A06(5/8"-11)	0.95kg
62090-07	NT40xER20A-45	138.4		34	M12x1.75P		1.20kg
62090-08	NT40xER25-55	148.4		42	M16x2.0P		1.25kg
62090-09	NT40xER32-60	153.4		50			1.30kg
62090-10	NT40xER40-70	163.4		63	M20x2.0P		1.35kg
62090-11	NT40xER50-80	173.4	78	M24x2.0P	2.00kg		
62090-12	NT50xER32-75	201.8	12	50	M16x2.0P	M24(M24*3.0P) A07(1"-8)	3.20kg
62090-13	NT50xER40-80	206.8		63	M20x2.0P		3.40kg
62090-14	NT50xER50-80	206.8		78	M24x2.0P		3.70kg

刀柄系列 Tooling System

62096

NT/MTA

斜柄鑽頭套筒 Morse Taper Adapter



刀柄系列
TOOLING SYSTEM



特點:

- ▶ 經硬化及精密研磨(內外徑)。
- ▶ 真圓度: 0.005mm。
- ▶ MTA=TANG型=DIN 228-B。
- ▶ MTB=拉桿類型=DIN 228-A。
- ▶ 採高級工具鋼經過完全淬火和磨削。內孔和外柄為莫氏錐度。

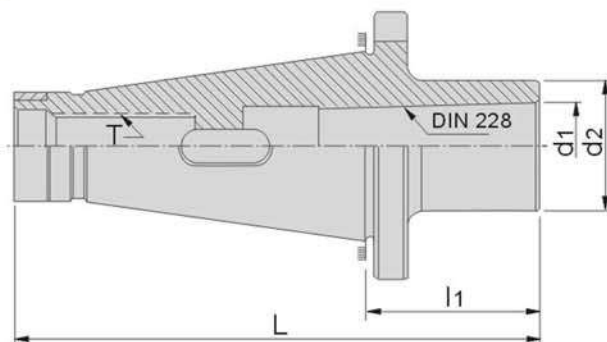

訂購時,請確認拉桿螺絲規格為公製或英製。

單位:mm

訂購編號 Order No.	型號 Model	l ₁	L	d ₁	d ₂	T	重量 N.W.
62096-01	NT30xMTA2	55.5	123.9	17.78	32	M12(M12*1.75P) A04(1/2"-12)	0.50kg
62096-02	NT30xMTA3	74	142.4	23.825	40		0.55kg
62096-03	NT40xMTA2	25	118.4	17.78	32	M16(M16*2.0P) A06(5/8"-11)	0.80kg
62096-04	NT40xMTA3	47	140.4	23.825	40		0.85kg
62096-05	NT40xMTA4	82	175.4	31.267	48		1.25kg
62096-06	NT40xMTA5	170	263.4	44.399	63		1.45kg
62096-07	NT50xMTA2	20	146.8	17.78	32	M24(M24*3.0P) A07(1"-8)	2.80kg
62096-08	NT50xMTA3	30	156.8	23.825	40		2.90kg
62096-09	NT50xMTA4	60	186.8	31.267	48		3.00kg
62096-10	NT50xMTA5	86.2	209.8	44.399	63		3.10kg

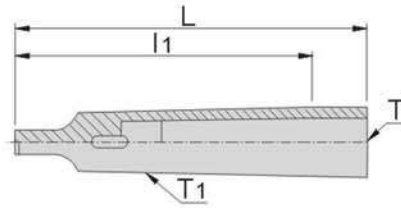
62098
MT
莫氏錐度套筒 Morse Taper Sleeve

單位:mm

訂購編號 Order No.	型號 Model	T	T1	L	l1
62098-01	MT1xMT2	MT1	MT2	89	75
62098-02	MT1xMT3	MT1	MT3	100	94
62098-03	MT2xMT3	MT2	MT3	112	94
62098-04	MT1xMT4	MT1	MT4	124	117.5
62098-05	MT2xMT4	MT2	MT4	124	117.5
62098-06	MT3xMT4	MT3	MT4	140	117.5
62098-07	MT1xMT5	MT1	MT5	156	149
62098-08	MT2xMT5	MT2	MT5	156	149
62098-09	MT3xMT5	MT3	MT5	156	149
62098-10	MT4xMT5	MT4	MT5	167	149
62098-11	MT4xMT6	MT4	MT6	220	210
62098-12	MT5xMT6	MT5	MT6	224	210

 刀柄系列
TOOLING SYSTEM

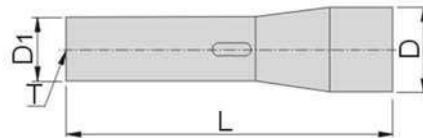
62100
R8/MT
套筒 R8 Drill Sleeve

單位:mm

訂購編號 Order No.	型號 Model	L	D	D1	T
62100-01	R8-MT1	124	32	24.1	7/16"UNF20
62100-02	R8-MT2	136.5			
62100-03	R8-MT3	150			
62100-04	R8-MT4	245			

62101
MT2-5
斜度退刀器 Drift

特點:

- 本產品系以特殊鋼經精密模鍛造而成,尖端部分熱處理,堅硬耐用,手柄內部採用高韌性彈簧,具大動力,輕易退刀。

訂購編號 Order No.	型號 Model	適用斜度	全長	重量 N.W.	單支盒裝尺寸	20支盒裝箱尺寸
62101	MT2-5	M.T.#2 #3 #4 #5	380mm	1.3kg	390x45x37mm	410x200x225mm

刀柄系列 Tooling System

62116

MTB/ER

銑床夾頭柄 Collet Holder

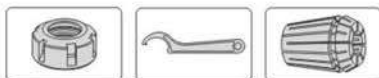
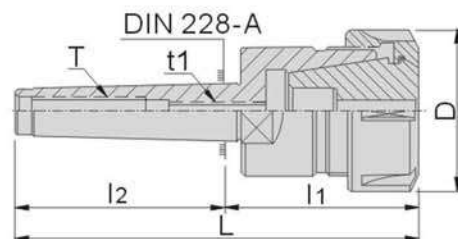

P.F81

P.F82

P.F74-77

單位:mm

訂購編號 Order No.	型號-I1 Model	l ₂	L	D	t ₁	T 拉桿規格	重量 N.W.
62116-01	MTB2xER20A-52	64	116	35	M10X1.5P	M10(M10*1.5P), A02(3/8"-16)	0.45kg
62116-02	MTB2xER25-55		119	42			0.50kg
62116-03	MTB3xER25-55	81	136	42	M12X1.75P	M12(M12*1.75P), A04(1/2"-12)	0.60kg
62116-04	MTB3xER32-60		141	50			0.80kg
62116-05	MTB3xER40-70		151	63			1.30kg
62116-06	MTB4xER32-60	102.5	162.5	50	M16X2.0P	M16(M16*2.0P), A06(5/8"-11)	0.95kg
62116-07	MTB4xER40-70		172.5	63			1.50kg

62118

R8/ER

銑床夾頭柄 Collet Holder

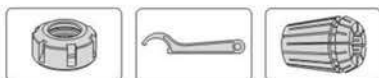
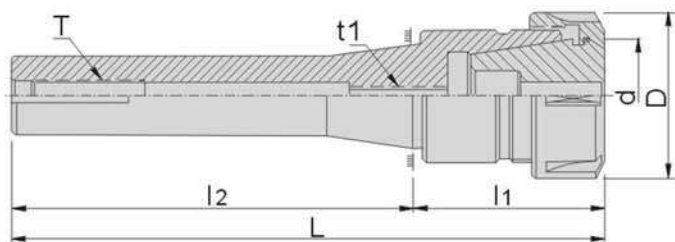

P.F81

P.F82

P.F74-77

單位:mm

訂購編號 Order No.	型號-I1 Model	l ₂	L	D	d	t ₁	T 拉桿規格	重量 N.W.
62118-01	R8xER16A-38	102	135	28	16	M10X1.5P	7/16" -20	0.65kg
62118-02	R8xER32-60		162	50	32	M12X1.75P		0.90kg
62118-03	R8xER40-65		168	63	40	M16X2.0P		1.10kg

62120
C/ER
直柄彈性筒夾本體 Straight Shank

P.F81
P.F82
P.F73~77

單位:mm

訂購編號 Order No.	型號 Model	D1	L1	L	D	型式
62120-01	C20-ER16-50	20	50	30	28	ER16
62120-02	C20-ER16-100		100			
62120-03	C20-ER16-150		150			
62120-04	C20-ER20-50	20	50	36	34	ER20
62120-05	C20-ER20-100		100			
62120-06	C20-ER25-50		50			
62120-07	C20-ER25-100	25	100	46	42	ER25
62120-08	C20-ER25-150		150			
62120-09	C25-ER16-100		100			
62120-10	C25-ER16-150	25	150	30	28	ER16
62120-11	C25-ER20-150		150			
62120-12	C25-ER25-100		100			
62120-13	C25-ER25-150	25	150	46	42	ER25
62120-14	C25-ER32-80		80			
62120-15	C25-ER40-100		100			
62120-16	C32-ER25-60	32	60	46	42	ER25
62120-17	C32-ER32-100		100			
62120-18	C32-ER40-100		55			
62120-19	C40-ER32-100	40	100	54	50	ER32
62120-20	C40-ER40-100					

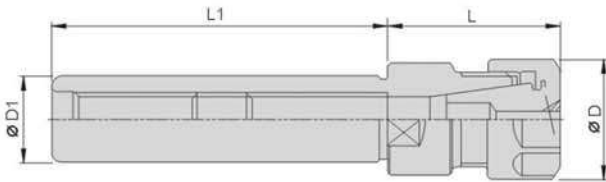

(本產品不含筒夾)

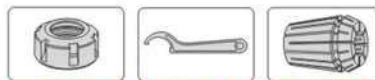
62122
C/ER
直柄彈性筒夾本體(M型) Straight Shank

P.F81
P.F82
P.F73~77

單位:mm

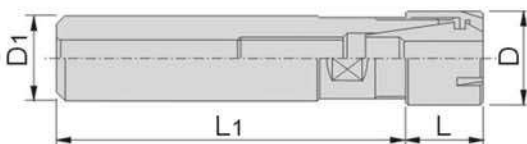
訂購編號 Order No.	型號 Model	D1	L1	L	D	型式
62122-01	C16-ER11-50M	16	50	12	16	ER11
62122-02	C16-ER11-100M		100			
62122-03	C20-ER16-50M	20	50	18	22	ER16
62122-04	C20-ER16-100M		100			
62122-05	C20-ER16-150M		150			
62122-06	C20-ER20-50M	20	50	19	28	ER20
62122-07	C20-ER20-100M		100			
62122-08	C20-ER20-150M		150			
62122-09	C25-ER20-50M	25	50	19	28	ER20
62122-10	C25-ER20-100M		100			
62122-11	C25-ER20-150M		150			



(本產品不含筒夾及刀具)

刀柄系列 Tooling System

62124
ST/ER
銑床夾頭組
ER Spring Collet Chuck System Set Of Collets and Straight Shank

 刀柄系列
TOOLING SYSTEM

本體請參照P.F52

訂購編號 Order No.	型號 Model	Set Range	Collet	重量 N.W.
62124-01	ST16-ER11-50-13PCS	1-7	ER11 13PCS	0.6kg
62124-02	ST16-ER11-50-7PCS	1-7	ER11 7PCS	0.5kg
62124-03	ST16-ER11-100-13PCS	1-7	ER11 13PCS	0.7kg
62124-04	ST16-ER11-100-7PCS	1-7	ER11 7PCS	0.6kg
62124-05	ST16-ER16-100-10PCS	1-10	ER16 10PCS	1kg
62124-06	ST16-ER16-100-8PCS	3-10	ER16 8PCS	1kg
62124-07	ST20-ER16-50-10PCS	1-10	ER16 10PCS	1.05kg
62124-08	ST20-ER16-50-8PCS	3-10	ER16 8PCS	1kg
62124-09	ST20-ER16-100-10PCS	1-10	ER16 10PCS	1.1kg
62124-10	ST20-ER16-100-8PCS	3-10	ER16 8PCS	1.05kg
62124-11	ST20-ER16-150-10PCS	1-10	ER16 10PCS	1.2kg
62124-12	ST20-ER16-150-8PCS	3-10	ER16 8PCS	1.15kg
62124-13	ST25-ER16-50-10PCS	1-10	ER16 10PCS	1.1kg
62124-14	ST25-ER16-50-8PCS	3-10	ER16 8PCS	1.05kg
62124-15	ST25-ER16-100-10PCS	1-10	ER16 10PCS	1.2kg
62124-16	ST25-ER16-100-8PCS	3-10	ER16 8PCS	1.15kg
62124-17	ST25-ER16-150-10PCS	1-10	ER16 10PCS	1.35kg
62124-18	ST25-ER16-150-8PCS	3-10	ER16 8PCS	1.3kg
62124-19	ST20-ER20-50-12PCS	2-13	ER20 12PCS	1.2kg
62124-20	ST20-ER20-50-10PCS	4-13	ER20 10PCS	1.15kg
62124-21	ST20-ER20-100-12PCS	2-13	ER20 12PCS	1.3kg
62124-22	ST20-ER20-100-10PCS	4-13	ER20 10PCS	1.25kg

62124
ST/ER
銑床夾頭組
ER Spring Collet Chuck System Set Of Collets and Straight Shank

本體請參照P.F52

訂購編號 Order No.	型號 Model	Set Range	Collet	重量 N.W.
62124-23	ST20-ER20-150-12PCS	2-13	ER20 12PCS	1.4kg
62124-24	ST20-ER20-150-10PCS	4-13	ER20 10PCS	1.35kg
62124-25	ST25-ER20-50-12PCS	2-13	ER20 12PCS	1.3kg
62124-26	ST25-ER20-50-10PCS	4-13	ER20 10PCS	1.25kg
62124-27	ST25-ER20-100-12PCS	2-13	ER20 12PCS	1.4kg
62124-28	ST25-ER20-100-10PCS	4-13	ER20 10PCS	1.35kg
62124-29	ST25-ER20-150-12PCS	2-13	ER20 12PCS	1.5kg
62124-30	ST25-ER20-150-10PCS	4-13	ER20 10PCS	1.45kg
62124-31	ST20-ER25-50-15PCS	2-16	ER25 15PCS	2.4kg
62124-32	ST20-ER25-50-7PCS	4-16	ER25 7PCS	1.9kg
62124-33	ST20-ER25-100-15PCS	2-16	ER25 15PCS	2.4kg
62124-34	ST20-ER25-100-7PCS	4-16	ER25 7PCS	1.9kg
62124-35	ST20-ER25-150-15PCS	2-16	ER25 15PCS	2.5kg
62124-36	ST20-ER25-150-7PCS	4-16	ER25 7PCS	2kg
62124-37	ST25-ER25-100-15PCS	2-16	ER25 15PCS	2.5kg
62124-38	ST25-ER25-100-7PCS	4-16	ER25 7PCS	2kg
62124-39	ST25-ER25-150-15PCS	2-16	ER25 15PCS	2.65kg
62124-40	ST25-ER25-150-7PCS	4-16	ER25 7PCS	2.2kg
62124-41	ST32-ER25-60-15PCS	2-16	ER25 15PCS	2.5kg
62124-42	ST32-ER25-60-7PCS	4-16	ER25 7PCS	2kg
62124-43	ST25-ER32-80-18PCS	3-20	ER32 18PCS	4.1kg
62124-44	ST25-ER32-80-11PCS	4-20	ER32 11PCS	3kg
62124-45	ST25-ER32-80-6PCS	6-20	ER32 6PCS	2.7kg
62124-46	ST32-ER32-100-18PCS	3-20	ER32 18PCS	4.3kg
62124-47	ST32-ER32-100-11PCS	4-20	ER32 11PCS	3.2kg
62124-48	ST32-ER32-100-6PCS	6-20	ER32 6PCS	2.9kg
62124-49	ST40-ER32-100-18PCS	3-20	ER32 18PCS	4.5kg
62124-50	ST40-ER32-100-11PCS	4-20	ER32 11PCS	3.4kg
62124-51	ST40-ER32-100-6PCS	6-20	ER32 6PCS	3.1kg
62124-52	ST32-ER40-100-23PCS	4-26	ER40 23PCS	7.3kg
62124-53	ST32-ER40-100-15PCS	4-26	ER40 15PCS	6.1kg
62124-54	ST32-ER40-100-7PCS	6-25	ER40 7PCS	4.6kg
62124-55	ST40-ER40-100-23PCS	4-26	ER40 23PCS	7.6kg
62124-56	ST40-ER40-100-15PCS	4-26	ER40 15PCS	6.5kg
62124-57	ST40-ER40-100-7PCS	6-25	ER40 7PCS	5kg

 刀柄系列
TOOLING SYSTEM

刀柄系列 Tooling System

62126

ST/ER

銑床夾頭組

ER Spring Collet Chuck System Set Of Collets and MINI Straight Shank



本體請參照P.F52

訂購編號 Order No.	型號 Model	Set Range	Collet	重量 N.W.
62126-01	ST16-ER11M-50-13PCS	1-7	ER11 13PCS	0.6kg
62126-02	ST16-ER11M-100-13PCS	1-7	ER11 13PCS	0.7kg
62126-03	ST16-ER16M-100-10PCS	1-10	ER16 10PCS	1kg
62126-04	ST20-ER16M-50-10PCS	1-10	ER16 10PCS	1.05kg
62126-05	ST20-ER16M-100-10PCS	1-10	ER16 10PCS	1.1kg
62126-06	ST20-ER16M-150-10PCS	1-10	ER16 10PCS	1.2kg
62126-07	ST25-ER16M-100-10PCS	1-10	ER16 10PCS	1.2kg
62126-08	ST25-ER16M-150-10PCS	1-10	ER16 10PCS	1.35kg
62126-09	ST20-ER20M-50-12PCS	2-13	ER20 12PCS	1.2kg
62126-10	ST20-ER20M-100-12PCS	2-13	ER20 12PCS	1.3kg
62126-11	ST20-ER20M-150-12PCS	2-13	ER20 12PCS	1.4kg
62126-12	ST25-ER20M-100-12PCS	2-13	ER20 12PCS	1.4kg
62126-13	ST25-ER20M-150-12PCS	2-13	ER20 12PCS	1.5kg

62128

R8/ER

銑床夾頭組

ER Spring Collet Chuck System Set Of Collets and R8 Shank



本體請參照P.F51

訂購編號 Order No.	型號 Model	Set Range	Collet	重量 N.W.
62128-01	R8-ER16-38-10PCS	1-10	ER16 10PCS	1.5kg
62128-02	R8-ER32-40-18PCS	3-20	ER32 18PCS	4.3kg
62128-03	R8-ER32-40-11PCS	4-20	ER32 11PCS	3.2kg
62128-04	R8-ER32-40-6PCS	6-20	ER32 6PCS	2.9kg
62128-05	R8-ER40-70-23PCS	4-26	ER40 23PCS	7.3kg
62128-06	R8-ER40-70-15PCS	4-26	ER40 15PCS	6.1kg
62128-07	R8-ER40-70-7PCS	6-25	ER40 7PCS	4.6kg

62130

MT/ER

銑床夾頭組
ER Spring Collet Chuck System Set Of Collets and MT Shank

 刀柄系列
TOOLING SYSTEM

本體請參照P.F51

訂購時,請確認拉桿螺絲規格為公製或英製。

訂購編號 Order No.	型號 Model	Set Range	Collet	重量 N.W.	Draw Bar
62130-01	MTB2-ER16-40-10PCS	1-10	ER16 10PCS	1.05	M10(M10*1.5P) A02(3/8"-16)
62130-02	MTB2-ER20-43-12PCS	2-13	ER20 12PCS	1.3	
62130-03	MTB2-ER25-47-15PCS	2-16	ER25 15PCS	2.4	
62130-04	MTB2-ER25-47-7PCS	4-16	ER25 7PCS	2	M10(M10*1.5P) M12(M12*1.75P) A04(1/2"-12) A05(1/2"-13) A02(3/8"-16)
62130-05	MTB3-ER16-40-10PCS	1-10	ER16 10PCS	1.15	
62130-06	MTB3-ER20-43-12PCS	2-13	ER20 12PCS	1.35	
62130-07	MTB3-ER25-47-15PCS	2-16	ER25 15PCS	2.5	
62130-08	MTB3-ER25-47-7PCS	4-16	ER25 7PCS	2.1	
62130-09	MTB3-ER32-70-18PCS	3-20	ER32 18PCS	4.1	
62130-10	MTB3-ER32-70-11PCS	4-20	ER32 11PCS	3	
62130-11	MTB3-ER32-70-6PCS	6-20	ER32 6PCS	2.7	
62130-12	MTB3-ER40-80-23PCS	4-26	ER40 23PCS	7.2	
62130-13	MTB3-ER40-80-15PCS	4-26	ER40 15PCS	6	
62130-14	MTB3-ER40-80-7PCS	6-25	ER40 7PCS	4.5	M16(M16*2.0P) A06(5/8"-11)
62130-15	MTB4-ER32-60-18PCS	3-20	ER32 18PCS	4.3	
62130-16	MTB4-ER32-60-11PCS	4-20	ER32 11PCS	3.2	
62130-17	MTB4-ER32-60-6PCS	6-20	ER32 6PCS	2.9	
62130-18	MTB4-ER40-82-23PCS	4-26	ER40 23PCS	7.3	
62130-19	MTB4-ER40-82-15PCS	4-26	ER40 15PCS	6.1	M24(M24*3.0P) A07(1"-8)
62130-20	MTB4-ER40-82-7PCS	6-25	ER40 7PCS	4.6	
62130-21	MTB5-ER40-82-23PCS	4-26	ER40 23PCS	8.2	
62130-22	MTB5-ER40-82-15PCS	4-26	ER40 15PCS	6.9	
62130-23	MTB5-ER40-82-7PCS	6-25	ER40 7PCS	5.4	
62130-24	MTB5-ER50-85-12PCS	12-34	ER50 12PCS	9.5	

刀柄系列 Tooling System

62132

NT/ER

銑床夾頭組

ER Spring Collet Chuck System Set Of Collets and NT Shank

刀柄系列
TOOLING SYSTEM



本體請參照P.F48

訂購時,請確認拉桿螺絲規格為公製或英製。

訂購編號 Order No.	型號 Model	Set Range	Collet	重量 N.W.	Draw Bar
62132-01	NT30-ER16-76-10PCS	1-10	ER16 10PCS	1.7	M12(M12*1.75P) A04(1/2"-12)
62132-02	NT30-ER20-76-12PCS	2-13	ER20 12PCS	1.8	
62132-03	NT30-ER25-55-15PCS	2-16	ER25 15PCS	2.8	
62132-04	NT30-ER25-55-7PCS	4-16	ER25 7PCS	2.4	
62132-05	NT30-ER32-55-18PCS	3-20	ER32 18PCS	4.2	M12(M12*1.75P) A04(1/2"-12) A05(1/2"-13)
62132-06	NT30-ER32-55-11PCS	4-20	ER32 11PCS	3.2	
62132-07	NT30-ER32-55-6PCS	6-20	ER32 6PCS	2.8	
62132-08	NT30-ER40-70-23PCS	4-26	ER40 23PCS	7.3	
62132-09	NT30-ER40-70-15PCS	4-26	ER40 15PCS	6	
62132-10	NT30-ER40-70-7PCS	6-25	ER40 7PCS	4.6	
62132-11	NT40-ER16-76-10PCS	1-10	ER16 10PCS	2.4	M16(M16*2.0P) A06(5/8"-11)
62132-12	NT40-ER20-76-12PCS	2-13	ER20 12PCS	2.5	
62132-13	NT40-ER25-50-15PCS	2-16	ER25 15PCS	3.3	
62132-14	NT40-ER25-50-7PCS	4-16	ER25 7PCS	3	
62132-15	NT40-ER32-50-18PCS	3-20	ER32 18PCS	4.8	M16(M16*2.0P) A06(5/8"-11)
62132-16	NT40-ER32-50-11PCS	4-20	ER32 11PCS	3.8	
62132-17	NT40-ER32-50-6PCS	6-20	ER32 6PCS	3.4	
62132-18	NT40-ER40-60-23PCS	4-26	ER40 23PCS	8.2	
62132-19	NT40-ER40-60-15PCS	4-26	ER40 15PCS	6.9	
62132-20	NT40-ER40-60-7PCS	6-25	ER40 7PCS	5.2	
62132-21	NT40-ER50-80-12PCS	12-34	ER50 12PCS	10	M24(M24*3.0P) A07(1"-8)
62132-22	NT50-ER32-60-18PCS	3-20	ER32 18PCS	6.4	
62132-23	NT50-ER32-60-11PCS	4-20	ER32 11PCS	5.4	
62132-24	NT50-ER32-60-6PCS	6-20	ER32 6PCS	5	
62132-25	NT50-ER40-65-23PCS	4-26	ER40 23PCS	9.8	
62132-26	NT50-ER40-65-15PCS	4-26	ER40 15PCS	8.5	
62132-27	NT50-ER40-65-7PCS	6-25	ER40 7PCS	7	
62132-28	NT50-ER50-65-12PCS	12-34	ER50 12PCS	11	

62134
BT/ER
銑床夾頭組
ER Spring Collet Chuck System Set Of Collets And Mas403 BT30/40/50 Shank

 刀柄系列
TOOLING SYSTEM

本體請參照P.F14~16

訂購編號 Order No.	型號 Model	Set Range	Collet	重量 N.W.
62134-01	BT30-ER16-60-10PCS	1-10	ER16 10PCS	1.9kg
62134-02	BT30-ER16-100-10PCS	1-10	ER16 10PCS	2kg
62134-03	BT30-ER20-60-12PCS	2-13	ER20 12PCS	2.5kg
62134-04	BT30-ER20-100-12PCS	2-13	ER20 12PCS	2.6kg
62134-05	BT30-ER25-60-15PCS	2-16	ER25 15PCS	2.5kg
62134-06	BT30-ER25-60-7PCS	4-16	ER25 7PCS	2.8kg
62134-07	BT30-ER32-60-18PCS	3-20	ER32 18PCS	4.4kg
62134-08	BT30-ER32-60-11PCS	4-20	ER32 11PCS	3.8kg
62134-09	BT30-ER32-60-6PCS	6-20	ER32 6PCS	3.4kg
62134-10	BT40-ER16-70-10PCS	1-10	ER16 10PCS	2.3kg
62134-11	BT40-ER16-100-10PCS	1-10	ER16 10PCS	2.7kg
62134-12	BT40-ER20-70-12PCS	2-13	ER20 12PCS	2.8kg
62134-13	BT40-ER20-100-12PCS	2-13	ER20 12PCS	3kg
62134-14	BT40-ER25-70-15PCS	2-16	ER25 15PCS	3.2kg
62134-15	BT40-ER25-100-7PCS	4-16	ER25 7PCS	3kg
62134-16	BT40-ER32-70-18PCS	3-20	ER32 18PCS	5.2kg
62134-17	BT40-ER32-70-11PCS	4-20	ER32 11PCS	4.2kg
62134-18	BT40-ER32-70-6PCS	6-20	ER32 6PCS	3.8kg
62134-19	BT40-ER40-80-23PCS	4-26	ER40 23PCS	8.9kg
62134-20	BT40-ER40-80-15PCS	4-26	ER40 15PCS	7.6kg
62134-21	BT40-ER40-80-7PCS	6-25	ER40 7PCS	4.5kg
62134-22	BT40-ER50-90-12PCS	12-34	ER50 12PCS	9kg
62134-23	BT50-ER32-100-18PCS	3-20	ER32 18PCS	7.5kg
62134-24	BT50-ER40-100-23PCS	4-26	ER40 23PCS	11.3kg
62134-25	BT50-ER40-100-15PCS	4-26	ER40 15PCS	10kg
62134-26	BT50-ER50-100-12PCS	12-34	ER50 12PCS	12kg

刀柄系列 Tooling System

62136

DAT/ER

銑床夾頭組

ER Spring Collet Chuck System Set Of Collets And DIN69871A DAT Shank

刀柄系列
TOOLING SYSTEM



本體請參照P.F32~34

訂購編號 Order No.	型號 Model	Set Range	Collet	重量 N.W.
62136-01	DAT30-ER16-60-10PCS	1-10	ER16 10PCS	1.8kg
62136-02	DAT30-ER20-60-12PCS	2-13	ER20 12PCS	2.4kg
62136-03	DAT30-ER25-60-15PCS	2-16	ER25 15PCS	2.7kg
62136-04	DAT30-ER32-60-18PCS	3-20	ER32 18PCS	4.2kg
62136-05	DAT40-ER16-70-10PCS	1-10	ER16 10PCS	2.2kg
62136-06	DAT40-ER20-70-12PCS	2-13	ER20 12PCS	2.7kg
62136-07	DAT40-ER25-70-15PCS	2-16	ER25 15PCS	3.1kg
62136-08	DAT40-ER32-70-18PCS	3-20	ER32 18PCS	5.2kg
62136-09	DAT40-ER40-80-23PCS	4-26	ER40 23PCS	8.9kg
62136-10	DAT40-ER40-80-15PCS	4-26	ER40 15PCS	7.0kg
62136-11	DAT50-ER32-100-18PCS	3-20	ER32 18PCS	7.0kg
62136-12	DAT50-ER40-100-15PCS	4-26	ER40 15PCS	9.5kg
62136-13	DAT50-ER40-100-23PCS	4-26	ER50 23PCS	11.3kg

62138 OZ 銑床夾頭 Collet Chuck

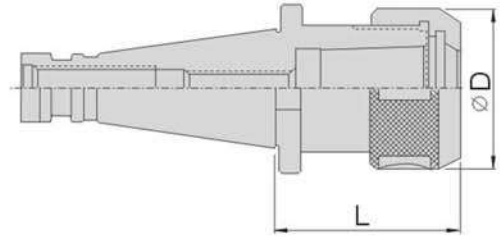

P.F61

單位:mm

OZ25 訂購時,請確認拉桿螺絲規格為公製或英製。

訂購編號 Order No.	型號 Model	L	∅D	Collet	Braw Bar	重量 N.W.
62138-01	NT30-OZ25-70	70	60	OZ25	M12(M12*1.75P) A04(1/2"-12) A05(1/2"-13)	1.0kg
62138-02	NT40-OZ25-70	70	60	OZ25	M16(M16*2.0P) A06(5/8"-11)	1.3kg
62138-03	NT50-OZ25-73	73	60	OZ25	M24(M24*3.0P) A07(1"-8)	3.2kg
62138-04	MTB2-OZ25-85	85	60	OZ25	M10*1.5P	1.0kg
62138-05	MTB3-OZ25-70	70	60	OZ25	M10(M10*1.5P) M12(M12*1.75P) A04(1/2"-12) A05(1/2"-13) A02(3/8"-16)	1.0kg
62138-06	MTB4-OZ25-70	70	60	OZ25	M16(M16*2.0P) A06(5/8"-11)	1.2kg
62138-07	MTB5-OZ25-65	65	60	OZ25	M24(M24*3.0P) A07(1"-8)	2.0kg
62138-08	R8-OZ25-70	70	60	OZ25	7/16"-20	1.2kg
62138-09	BT30-OZ25-70	70	60	OZ25	M12*1.75P	0.9kg
62138-10	BT40-OZ25-80	80	60	OZ25	M16*2.0P	1.5kg
62138-11	BT50-OZ25-100	100	60	OZ25	M24*3.0P	4.3kg
62138-12	SK40-OZ25-80	80	60	OZ25	M16*2.0P	1.9kg
62138-13	SK50-OZ25-100	100	60	OZ25	M24*3.0P	4.2kg
62138-14	CAT40-OZ25-3"	3"	60	OZ25	5/8"-11	1.9kg
62138-15	CAT50-OZ25-3 1/2"	3 1/2"	60	OZ25	1"-8	4.0kg

OZ32

62138-20	NT30-OZ32-100	100	78	OZ32	M12(M12*1.75P) A04(1/2"-12)	2.0kg
62138-21	NT40-OZ32-85	85	78	OZ32	M16(M16*2.0P) A06(5/8"-11)	2.2kg
62138-22	NT50-OZ32-80	80	78	OZ32	M24(M24*3.0P) A07(1"-8)	4.8kg
62138-23	MTB5-OZ32-100	100	78	OZ32	M24(M24*3.0P) A07(1"-8)	3.0kg
62138-24	BT40-OZ32-90	90	78	OZ32	M16*2.0P	2.3kg
62138-25	BT50-OZ32-100	100	78	OZ32	M24*3.0P	5.0kg
62138-26	BT50-OZ32-150	150	78	OZ32	M24*3.0P	6.0kg
62138-27	SK40-OZ32-80	80	78	OZ32	M16*2.0P	2.3kg
62138-28	SK50-OZ32-100	100	78	OZ32	M24*3.0P	5.0kg
62138-29	CAT40-OZ32-3"	3"	78	OZ32	5/8"-11	2.3kg
62138-30	CAT50-OZ32-3 1/2"	3 1/2"	78	OZ32	1"-8	5.0kg

刀柄系列 Tooling System

62142 OZ25 筒夾 Collets

刀柄系列
TOOLING SYSTEM



特點:

- ▶ HRC:47°
- ▶ 筒夾精度:標準
- ▶ 夾持範圍:≤0.5mm

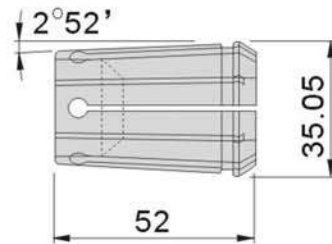

METRIC SIZE

訂購編號 Order No.	型號 Model	夾持 ∅
62142-03	OZ2503	3
62142-04	OZ2504	4
62142-05	OZ2505	5
62142-06	OZ2506	6
62142-07	OZ2507	7
62142-08	OZ2508	8
62142-09	OZ2509	9
62142-10	OZ2510	10
62142-11	OZ2511	11
62142-12	OZ2512	12
62142-13	OZ2513	13
62142-14	OZ2514	14
62142-15	OZ2515	15
62142-16	OZ2516	16
62142-17	OZ2517	17
62142-18	OZ2518	18
62142-19	OZ2519	19
62142-20	OZ2520	20
62142-21	OZ2521	21
62142-22	OZ2522	22
62142-23	OZ2523	23
62142-24	OZ2524	24
62142-25	OZ2525	25

特點:

- ▶ HRC: 47°
- ▶ 筒夾精度: 標準
- ▶ 夾持範圍: ≤0.5mm

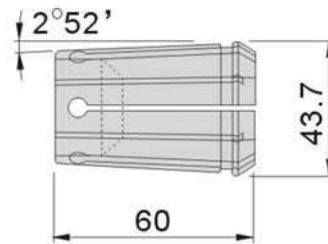
METRIC SIZE

訂購編號 Order No.	型號 Model	夾持 ∅
62144-06	OZ3206	6
62144-07	OZ3207	7
62144-08	OZ3208	8
62144-09	OZ3209	9
62144-10	OZ3210	10
62144-11	OZ3211	11
62144-12	OZ3212	12
62144-13	OZ3213	13
62144-14	OZ3214	14
62144-15	OZ3215	15
62144-16	OZ3216	16
62144-17	OZ3217	17
62144-18	OZ3218	18
62144-19	OZ3219	19
62144-20	OZ3220	20
62144-21	OZ3221	21
62144-22	OZ3222	22
62144-23	OZ3223	23
62144-24	OZ3224	24
62144-25	OZ3225	25
62144-26	OZ3226	26
62144-27	OZ3227	27
62144-28	OZ3228	28
62144-29	OZ3229	29
62144-30	OZ3230	30
62144-31	OZ3231	31
62144-32	OZ3232	32

刀柄系列 Tooling System

62146
OZ25
銑床夾頭組 Collet Chuck Kit

P.F61

公製

訂購編號 Order No.	型號 Model	個數	拉桿螺紋	重量 N.W.
62146-01	NT30-OZ25	7	M12(M12*1.75P)	3.7kg
62146-02	NT30-OZ25	15	A04(1/2"-12) A05(1/2"-13)	5.2kg
62146-03	NT40-OZ25	7	M16(M16*2.0P)	4kg
62146-04	NT40-OZ25	15	A06(5/8"-11)	5.5kg
62146-05	NT50-OZ25	7	M24(M24*3.0P)	6.5kg
62146-06	NT50-OZ25	15	A07(1"-8)	8.5kg
62146-07	MTB2-OZ25	7	M10(M10*1.5P)	3.6kg
62146-08	MTB2-OZ25	15	A02(3/8"-16)	5.1kg
62146-09	MTB3-OZ25	7	M10(M10*1.5P) M12(M12*1.75P)	3.7kg
62146-10	MTB3-OZ25	15	A04(1/2"-12) A05(1/2"-13) A02(3/8"-16)	5.2kg
62146-11	MTB4-OZ25	7	M16(M16*2.0P)	3.9kg
62146-12	MTB4-OZ25	15	A06(5/8"-11)	5.4kg
62146-13	MTB5-OZ25	7	M24(M24*3.0P)	4.7kg
62146-14	MTB5-OZ25	15	A07(1"-8)	6.2kg
62146-15	R8-OZ25	7	7/16"-20	3.7kg
62146-16	R8-OZ25	15		5.2kg
62146-17	BT40-OZ25	7		4.4kg
62146-18	BT40-OZ25	15		5.9kg
62146-19	BT50-OZ25	7		7.5kg
62146-20	BT50-OZ25	15		9.5kg
62146-21	SK40-OZ25	7	DIN69871A40 M16*2.0P	4.2kg
62146-22	SK40-OZ25	15		5.7kg
62146-23	SK50-OZ25	7	DIN69871A50 M24*3.0P	7.3kg
62146-24	SK50-OZ25	15		9.3kg

套裝公制筒夾型號

7PCS:6,8,10,12,16,20,25

15PCS:3,4,5,6,7,8,9,10,11,12,13,16,18,20,25

62148
OZ32
銑床夾頭組 Collet Chuck Kit

P.F62

公製

訂購編號 Order No.	型號 Model	個數	拉桿螺紋	重量 N.W.
62148-01	NT30-OZ32	8	M12(M12*1.75P)	7kg
62148-02	NT30-OZ32	15	A04(1/2"-12) A05(1/2"-13)	9kg
62148-03	NT40-OZ32	8	M16(M16*2.0P)	7.2kg
62148-04	NT40-OZ32	15	A06(5/8"-11)	9.2kg
62148-05	NT50-OZ32	8	M24(M24*3.0P)	9.8kg
62148-06	NT50-OZ32	15	A07(1"-8)	11.8kg
62148-07	MTB5-OZ32	8	M24(M24*3.0P)	8kg
62148-08	MTB5-OZ32	15	A07(1"-8)	10kg
62148-09	BT40-OZ32	8		7.4kg
62148-10	BT40-OZ32	15		9.4kg
62148-11	BT50-OZ32	8		10kg
62148-12	BT50-OZ32	15		12kg
62148-13	SK40-OZ32	8	DIN69871A40	7.2kg
62148-14	SK40-OZ32	15	M16*2.0P	9.2kg
62148-15	SK50-OZ32	8	DIN69871A50	9.8kg
62148-16	SK50-OZ32	15	M24*3.0P	11.8kg

套裝公製筒夾型號

8PCS:6,8,10,12,16,20,25,32

15PCS:6,8,10,12,13,14,15,16,18,20,22,25,26,30,32

刀柄系列 Tooling System

62150

NT-MCST

銑床夾頭 Milling Collet Chuck Holder

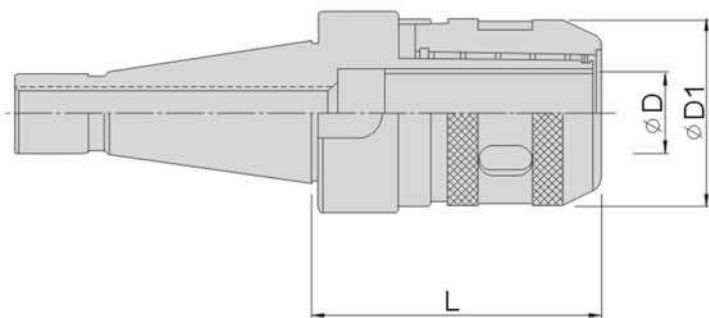

單位:mm

訂購編號 Order No.	型號 Model	∅D	∅D1	L	筒夾	拉桿螺紋	重量 N.W.
62150-01	NT30-MCST20-80	20	52	80	ST20	M12(M12*1.75P) A04(1/2"-12)	1.5kg
62150-02	NT30-MCST25-85	25	58	85	ST25		1.5kg
62150-03	NT40-MCST20-80	20	52	80	ST20	M16(M16*2.0P) A06(5/8"-11)	2.0kg
62150-04	NT40-MCST25-85	25	58	85	ST25		2.0kg
62150-05	NT40-MCST32-95	32	75	95	ST32		2.6kg
62150-06	NT50-MCST32-100	32	75	100	ST32	M24(M24*3.0P) A07(1"-8)	4.5kg
62150-07	NT50-MCST42-110	42	87	110	ST42		5.5kg

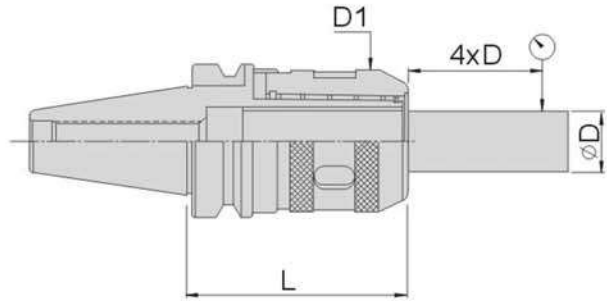
62152
BT-MCST
銑床夾頭
Milling Collet Chuck Holder

P.F67
P.F67

單位:mm

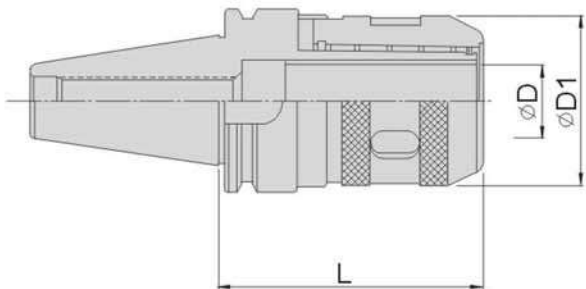
訂購編號 Order No.	型號 Model	ØD	D1	L	筒夾	重量 N.W.
62152-01	BT30-MCST20-85	20	52	85	ST20	1.5kg
62152-02	BT40-MCST20-80	20	52	80	ST20	2kg
62152-03	BT40-MCST20-120	20	52	120	ST20	2.8kg
62152-04	BT40-MCST25-90	25	58	90	ST25	2.2kg
62152-05	BT40-MCST25-135	25	58	135	ST25	2.9kg
62152-06	BT40-MCST32-105	32	75	105	ST32	3kg
62152-07	BT40-MCST32-150	32	75	150	ST32	3.5kg
62152-08	BT50-MCST32-110	32	75	110	ST32	5.2kg
62152-09	BT50-MCST32-150	32	75	150	ST32	7kg
62152-10	BT50-MCST42-115	42	87	115	ST42	7kg
62152-11	BT50-MCST42-150	42	87	150	ST42	8.5kg

62154
DAT-MCST
銑床夾頭
Milling Collet Chuck Holder

P.F67
P.F67

單位:mm

訂購編號 Order No.	型號 Model	ØD	ØD1	L	筒夾	重量 N.W.
62154-01	DAT30-MCST20-95	20	52	95	ST20	1.5kg
62154-02	DAT40-MCST20-80	20	52	80	ST20	2kg
62154-03	DAT40-MCST25-90	25	58	90	ST25	2kg
62154-04	DAT40-MCST32-100	32	75	100	ST32	2.7kg
62154-05	DAT50-MCST32-105	32	75	105	ST32	4.5kg
62154-06	DAT50-MCST42-110	42	87	110	ST42	5.7kg

刀柄系列 Tooling System

62156

ST

筒夾 Collets

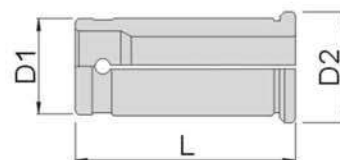

單位:mm

訂購編號 Order No.	型號 Model	Range Size(Metric)												D1	D2	L	重量 N.W.	
62156-01	ST20			6	8	10	12	14	15	16					20	25	52	0.10kg
62156-02	ST25	4	5	6	8	10	12	14	16	18	20				25	31	60	0.18kg
62156-03	ST32	4	5	6	8	10	12	14	16	18	20	22	25		32	37	73	0.22kg
62156-04	ST42			6	8	10	12	14	16	18	20	22	25	32	42	48	80	0.35kg

訂購編號 Order No.	型號 Model	Range Size(Imperial)												D1	D2	L	重量 N.W.	
62156-05	ST20	3/16	1/4	5/16	3/8	1/2	5/8								20	25	52	0.10kg
62156-06	ST25	3/16	1/4	5/16	3/8	1/2	5/8	3/4							25	31	60	0.18kg
62156-07	ST32	3/16	1/4	5/16	3/8	1/2	5/8	3/4	7/8	1"					32	37	73	0.22kg
62156-08	ST42		1/4	5/16	3/8	1/2	5/8	3/4	7/8	1"	1-1/4"				42	48	80	0.35kg

62158

MCST

扳手 Wrench

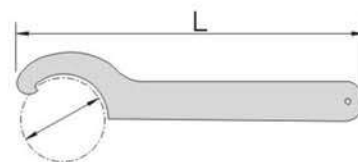

訂購編號 Order No.	型號 Model	L	D	重量 N.W.
62158-01	MCST20	227	52	0.22kg
62158-02	MCST25	227	58	0.22kg
62158-03	MCST32	260	75	0.33kg
62158-04	MCST42	270	87	0.35kg

62160
MCST
銑床夾頭組
Milling Collet Chuck System Kit

本體請參照P F66

訂購編號 Order No.	型號 Model	筒夾	拉桿螺紋	重量 N.W.
62160-01	NT30-MCST20-80-6PCS	ST20 6PCS	M12(M12*1.75P) A04(1/2"-12)	4.0kg
62160-02	NT30-MCST25-85-7PCS	ST25 7PCS		4.0kg
62160-03	NT40-MCST20-80-6PCS	ST20 6PCS	M16(M16*2.0P) A06(5/8"-11)	4.5kg
62160-04	NT40-MCST25-85-7PCS	ST25 7PCS		4.5kg
62160-05	NT40-MCST32-95-7PCS	ST32 7PCS		7.0kg
62160-06	NT50-MCST32-100-7PCS	ST32 7PCS	M24(M24*3.0P) A07(1"-8)	9.0kg
62160-07	NT50-MCST42-110-8PCS	ST42 8PCS		12.0kg
62160-08	BT30-MCST20-85-6PCS	ST20 6PCS		4.0kg
62160-09	BT40-MCST20-80-6PCS	ST20 6PCS		4.5kg
62160-10	BT40-MCST20-120-6PCS	ST20 6PCS		5.0kg
62160-11	BT40-MCST25-90-7PCS	ST25 7PCS		4.7kg
62160-12	BT40-MCST25-135-7PCS	ST25 7PCS		5.2kg
62160-13	BT40-MCST32-105-7PCS	ST32 7PCS		7.0kg
62160-14	BT50-MCST32-110-7PCS	ST32 7PCS		9.5kg
62160-15	BT50-MCST42-115-8PCS	ST42 8PCS		13.0kg
62160-16	DAT30-MCST20-95-6PCS	ST20 6PCS		4.0kg
62160-17	DAT40-MCST20-80-6PCS	ST20 6PCS		4.5kg
62160-18	DAT40-MCST25-90-7PCS	ST25 7PCS		4.8kg
62160-19	DAT40-MCST32-100-7PCS	ST32 7PCS		7.2kg
62160-20	DAT50-MCST32-105-7PCS	ST32 7PCS		9.1kg
62160-21	DAT50-MCST42-110-8PCS	ST42 8PCS		12.0kg

套裝公制筒夾型號

ST20 6PCS	4,6,8,10,12,16
ST25 7PCS	4,6,8,10,12,16,20
ST32 7PCS	6,8,10,12,16,20,25
ST42 8PCS	6,8,10,12,16,20,25,32

刀柄系列 Tooling System

62162

TP

直柄伸縮ER攻牙器 Straight Shank ER Tapper(For CNC Lathe)

刀柄系列
TOOLING SYSTEM



特點:

- ▶ 使用ER剛性筒夾。
- ▶ 主體是由SCM21材質制作,緊縮螺旋經過精密研磨。
- ▶ 靈活的設計,可以避免絲攻斷裂。
- ▶ 良好的浮動裝配可以自動校正工件重復裝夾的位置。
- ▶ 如果加工材料較硬,轉速相對變慢。
- ▶ 使用前,請確定車床主軸轉速,否則會因為速度太快或太慢,而導致絲攻斷裂或分離。

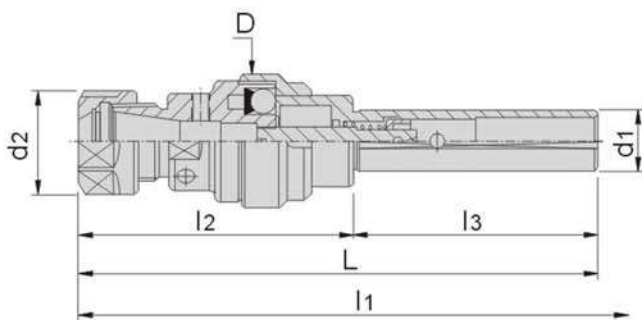

P.F81

P.F82

P.F73~78

單位:mm

訂購編號 Order No.	型號 Model	D	d1	d2	L	l1	l2	l3	COLLET	CAPACITY	重量 N.W.
62162-01	TP-20	44	20	34	159	172	79	80	ER20	M3~M16	0.5kg
62162-02	TP-225		25								0.7kg
62162-03	TP-232		32								0.9kg
62162-04	STP-20	37	20		155						1.0kg
62162-05	TP-32	56	32	50	174.5	190	94.5	80	ER32	M3~M27	1.6kg
62162-06	TPM-320	44	MT3	34	165	178	79	86	ER20	M3~M16	1.4kg
62162-07	TPM-420										1.6kg
62162-08	TPM-432		56	MT4	50	203.5	216.5	94.5	109	ER32	M3~M27

精度標準

2級	非常經濟、可靠,同時保證德規DIN6499二級精度(15-20微米)。完全符合所有一般用途的加工。
1級	合理的成本價格,精度高,保證德規DIN6499一級精度(10微米)。適合更精確的工作。提高使用工具的壽命。
0級	最高水平的精度,保證圓跳動在5微米以內,適合非常高精度、高轉速之應用。提高使用工具的壽命以及加工性能、表面質量和精度。

$\varnothing d$	L	DIN 6499 2級	DIN 6499 1級	GIN 0級
1~16	6	0.015	0.010	0.005
16~3	10	0.015	0.010	0.005
3~7	16	0.015	0.010	0.005
7~10	25	0.015	0.010	0.005
10~18	40	0.020	0.010	0.005
18~25	50	0.020	0.010	0.005
25~34	60	0.025	0.015	0.010

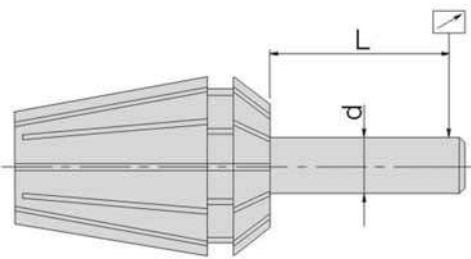

所有 GIN 筒夾:

各等級跳動情況均保證在所標示之範圍內。

跳動100%檢查。

當夾持到最小夾緊直徑時,不變形。

當跌落時,不會碎裂。

與刀杆組配性能良好,光滑的表面以及精確的幾何角度來適應夾盤和它的夾緊螺母。

從包裝帽的顏色可以很容易區分三種不同的精度等級

2級(最大跳動15~20微米)

1級(最大跳動10微米)

0級(最大跳動5微米)

ER筒夾 ER Collets

62168

ER8

筒夾 ER 8 Collets



刀柄系列
TOOLING SYSTEM

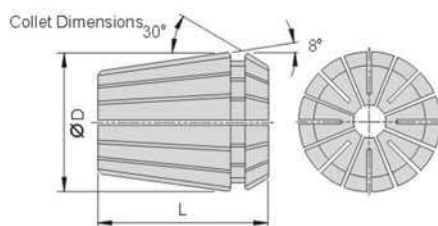

D	L	夾持範圍	夾持間格
8.5	13	1.0~5.0	0.5

ER8(2級)		
訂購編號 Order No.	型號 Model	夾持 ∅
62168-201	ER080102	1.0~0.5
62168-202	ER080152	1.5~1.0
62168-203	ER080202	2.0~1.5
62168-204	ER080252	2.5~2.0
62168-205	ER080302	3.0~2.5
62168-206	ER080352	3.5~3.0
62168-207	ER080402	4.0~3.5
62168-208	ER080452	4.5~4.0
62168-209	ER080502	5.0~4.5

ER8(1級)		
訂購編號 Order No.	型號 Model	夾持 ∅
62168-101	ER080101	1.0~0.5
62168-102	ER080151	1.5~1.0
62168-103	ER080201	2.0~1.5
62168-104	ER080251	2.5~2.0
62168-105	ER080301	3.0~2.5
62168-106	ER080351	3.5~3.0
62168-107	ER080401	4.0~3.5
62168-108	ER080451	4.5~4.0
62168-109	ER080501	5.0~4.5

62169

ER8

套裝筒夾(∅1~5mm 9個) ER 8 Collets Sets



ER8套裝筒夾(2級)		
訂購編號 Order No.	型號 Model	內容
62169-02	ER08SET2	9個ER8筒夾(2級), ∅1~5mm, 間隔增量0.5mm, 塑料盒裝。

ER8套裝筒夾(1級)		
訂購編號 Order No.	型號 Model	內容
62169-01	ER08SET1	9個ER8筒夾(1級), ∅1~5mm, 間隔增量0.5mm, 塑料盒裝。

62170 ER11 筒夾 ER 11 Collets



刀柄系列
TOOLING SYSTEM

D	L	夾持範圍	夾持間格
11.5	18	1.0~7.0	0.5

ER11(2級)		
訂購編號 Order No.	型號 Model	夾持 Ø
62170-201	ER110102	1.0~0.5
62170-202	ER110152	1.5~1.0
62170-203	ER110202	2.0~1.5
62170-204	ER110252	2.5~2.0
62170-205	ER110302	3.0~2.5
62170-206	ER110352	3.5~3.0
62170-207	ER110402	4.0~3.5
62170-208	ER110452	4.5~4.0
62170-209	ER110502	5.0~4.5
62170-210	ER110552	5.5~5.0
62170-211	ER110602	6.0~5.5
62170-212	ER110652	6.5~6.0
62170-213	ER110702	7.0~6.5

ER11(1級)		
訂購編號 Order No.	型號 Model	夾持 Ø
62170-101	ER110101	1.0~0.5
62170-102	ER110151	1.5~1.0
62170-103	ER110201	2.0~1.5
62170-104	ER110251	2.5~2.0
62170-105	ER110301	3.0~2.5
62170-106	ER110351	3.5~3.0
62170-107	ER110401	4.0~3.5
62170-108	ER110451	4.5~4.0
62170-109	ER110501	5.0~4.5
62170-110	ER110551	5.5~5.0
62170-111	ER110601	6.0~5.5
62170-112	ER110651	6.5~6.0
62170-113	ER110701	7.0~6.5

ER11(0級)(5微米)		
訂購編號 Order No.	型號 Model	夾持 Ø
62170-001	ER110100	1.0~0.5
62170-002	ER110150	1.5~1.0
62170-003	ER110200	2.0~1.5
62170-004	ER110250	2.5~2.0
62170-005	ER110300	3.0~2.5
62170-006	ER110350	3.5~3.0
62170-007	ER110400	4.0~3.5
62170-008	ER110450	4.5~4.0
62170-009	ER110500	5.0~4.5
62170-010	ER110550	5.5~5.0
62170-011	ER110600	6.0~5.5
62170-012	ER110650	6.5~6.0
62170-013	ER110700	7.0~6.5

62171 ER11 套裝筒夾(Ø1~7mm 13個) ER 11 Collets Sets



ER11套裝筒夾(2級)		
訂購編號 Order No.	型號 Model	內容
62171-02	ER11SET2	13個ER11筒夾(2級), Ø1~7mm, 間隔增量0.5mm, 塑料盒裝。

ER11套裝筒夾(1級)		
訂購編號 Order No.	型號 Model	內容
62171-01	ER11SET1	13個ER11筒夾(1級), Ø1~7mm, 間隔增量0.5mm, 塑料盒裝。

ER11套裝筒夾(0級)(5微米)		
訂購編號 Order No.	型號 Model	內容
62171-00	ER11SET0	13個ER11筒夾(0級), Ø1~7mm, 間隔增量0.5mm, 塑料盒裝。

ER筒夾 ER Collets

62172 ER16 筒夾 ER 16 Collets

刀柄系列
TOOLING SYSTEM



D	L	夾持範圍	夾持間格
17	27.5	1.0~10.0	1.0

ER16(2級)		
訂購編號 Order No.	型號 Model	夾持 ∅
62172-201	ER160102	1.0~0.5
62172-202	ER160152	1.5~1.0
62172-203	ER160202	2.0~1.0
62172-204	ER160302	3.0~2.0
62172-205	ER160402	4.0~3.0
62172-206	ER160502	5.0~4.0
62172-207	ER160602	6.0~5.0
62172-208	ER160702	7.0~6.0
62172-209	ER160802	8.0~7.0
62172-210	ER160902	9.0~8.0
62172-211	ER161002	10.0~9.0

ER16(1級)		
訂購編號 Order No.	型號 Model	夾持 ∅
62172-101	ER160101	1.0~0.5
62172-102	ER160151	1.5~1.0
62172-103	ER160201	2.0~1.0
62172-104	ER160301	3.0~2.0
62172-105	ER160401	4.0~3.0
62172-106	ER160501	5.0~4.0
62172-107	ER160601	6.0~5.0
62172-108	ER160701	7.0~6.0
62172-109	ER160801	8.0~7.0
62172-110	ER160901	9.0~8.0
62172-111	ER161001	10.0~9.0

ER16(0級)(5微米)		
訂購編號 Order No.	型號 Model	夾持 ∅
62172-001	ER160100	1.0~0.5
62172-002	ER160150	1.5~1.0
62172-003	ER160200	2.0~1.0
62172-004	ER160300	3.0~2.0
62172-005	ER160400	4.0~3.0
62172-006	ER160500	5.0~4.0
62172-007	ER160600	6.0~5.0
62172-008	ER160700	7.0~6.0
62172-009	ER160800	8.0~7.0
62172-010	ER160900	9.0~8.0
62172-011	ER161000	10.0~9.0

62173 ER16 套裝筒夾(∅1~10mm 10個) ER 16 Collets Sets



ER16套裝筒夾(2級)		
訂購編號 Order No.	型號 Model	內容
62173-02	ER16SET2	10個ER16筒夾(2級), ∅1~10mm, 間隔增量1.0mm, 塑料盒裝。

ER16套裝筒夾(1級)		
訂購編號 Order No.	型號 Model	內容
62173-01	ER16SET1	10個ER16筒夾(1級), ∅1~10mm, 間隔增量1.0mm, 塑料盒裝。

ER16套裝筒夾(0級)(5微米)		
訂購編號 Order No.	型號 Model	內容
62173-00	ER16SET0	10個ER16筒夾(0級), ∅1~10mm, 間隔增量1.0mm, 塑料盒裝。

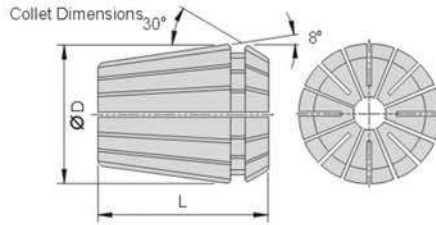
62174
ER20
筒夾 ER 20 Collets

D	L	夾持範圍	夾持間格
21	31.5	2.0~13.0	1.0

ER20(2級)		
訂購編號 Order No.	型號 Model	夾持 Ø
62174-203	ER200202	2.0~1.0
62174-204	ER200302	3.0~2.0
62174-205	ER200402	4.0~3.0
62174-206	ER200502	5.0~4.0
62174-207	ER200602	6.0~5.0
62174-208	ER200702	7.0~6.0
62174-209	ER200802	8.0~7.0
62174-210	ER200902	9.0~8.0
62174-211	ER201002	10.0~9.0
62174-212	ER201102	11.0~10.0
62174-213	ER201202	12.0~11.0
62174-214	ER201302	13.0~12.0

ER20(1級)		
訂購編號 Order No.	型號 Model	夾持 Ø
62174-103	ER200201	2.0~1.0
62174-104	ER200301	3.0~2.0
62174-105	ER200401	4.0~3.0
62174-106	ER200501	5.0~4.0
62174-107	ER200601	6.0~5.0
62174-108	ER200701	7.0~6.0
62174-109	ER200801	8.0~7.0
62174-110	ER200901	9.0~8.0
62174-111	ER201001	10.0~9.0
62174-112	ER201101	11.0~10.0
62174-113	ER201201	12.0~11.0
62174-114	ER201301	13.0~12.0

ER20(0級)(5微米)		
訂購編號 Order No.	型號 Model	夾持 Ø
62174-003	ER200200	2.0~1.0
62174-004	ER200300	3.0~2.0
62174-005	ER200400	4.0~3.0
62174-006	ER200500	5.0~4.0
62174-007	ER200600	6.0~5.0
62174-008	ER200700	7.0~6.0
62174-009	ER200800	8.0~7.0
62174-010	ER200900	9.0~8.0
62174-011	ER201000	10.0~9.0
62174-012	ER201100	11.0~10.0
62174-013	ER201200	12.0~11.0
62174-014	ER201300	13.0~12.0

62175
ER20
套裝筒夾(Ø2~13mm 12個) ER 20 Collets Sets

ER20套裝筒夾(2級)		
訂購編號 Order No.	型號 Model	內容
62175-02	ER20SET2	12個ER20筒夾(2級), Ø2~13mm, 間隔增量1.0mm, 塑料盒裝。

ER20套裝筒夾(1級)		
訂購編號 Order No.	型號 Model	內容
62175-01	ER20SET1	12個ER20筒夾(1級), Ø2~13mm, 間隔增量1.0mm, 塑料盒裝。

ER20套裝筒夾(0級)(5微米)		
訂購編號 Order No.	型號 Model	內容
62175-00	ER20SET0	12個ER20筒夾(0級), Ø2~13mm, 間隔增量1.0mm, 塑料盒裝。

ER筒夾 ER Collets

62176 ER25 筒夾 ER 25 Collets



D	L	夾持範圍	夾持間格
26	34	2.0~16.0	1.0

ER25(2級)		
訂購編號 Order No.	型號 Model	夾持 ∅
62176-203	ER250202	2.0~1.0
62176-204	ER250302	3.0~2.0
62176-205	ER250402	4.0~3.0
62176-206	ER250502	5.0~4.0
62176-207	ER250602	6.0~5.0
62176-208	ER250702	7.0~6.0
62176-209	ER250802	8.0~7.0
62176-210	ER250902	9.0~8.0
62176-211	ER251002	10.0~9.0
62176-212	ER251102	11.0~10.0
62176-213	ER251202	12.0~11.0
62176-214	ER251302	13.0~12.0
62176-215	ER251402	14.0~13.0
62176-216	ER251502	15.0~14.0
62176-217	ER251602	16.0~15.0

ER25(1級)		
訂購編號 Order No.	型號 Model	夾持 ∅
62176-103	ER250201	2.0~1.0
62176-104	ER250301	3.0~2.0
62176-105	ER250401	4.0~3.0
62176-106	ER250501	5.0~4.0
62176-107	ER250601	6.0~5.0
62176-108	ER250701	7.0~6.0
62176-109	ER250801	8.0~7.0
62176-110	ER250901	9.0~8.0
62176-111	ER251001	10.0~9.0
62176-112	ER251101	11.0~10.0
62176-113	ER251201	12.0~11.0
62176-114	ER251301	13.0~12.0
62176-115	ER251401	14.0~13.0
62176-116	ER251501	15.0~14.0
62176-117	ER251601	16.0~15.0

ER25(0級)(5微米)		
訂購編號 Order No.	型號 Model	夾持 ∅
62176-003	ER250200	2.0~1.0
62176-004	ER250300	3.0~2.0
62176-005	ER250400	4.0~3.0
62176-006	ER250500	5.0~4.0
62176-007	ER250600	6.0~5.0
62176-008	ER250700	7.0~6.0
62176-009	ER250800	8.0~7.0
62176-010	ER250900	9.0~8.0
62176-011	ER251000	10.0~9.0
62176-012	ER251100	11.0~10.0
62176-013	ER251200	12.0~11.0
62176-014	ER251300	13.0~12.0
62176-015	ER251400	14.0~13.0
62176-016	ER251500	15.0~14.0
62176-017	ER251600	16.0~15.0

62177 ER25 套裝筒夾(∅2~16mm 15個) ER 25 Collets Sets



ER25套裝筒夾(2級)		
訂購編號 Order No.	型號 Model	內容
62177-02	ER25SET2	15個ER25筒夾(2級), ∅2~16mm, 間隔增量1.0mm, 塑料盒裝。

ER25套裝筒夾(1級)		
訂購編號 Order No.	型號 Model	內容
62177-01	ER25SET1	15個ER25筒夾(1級), ∅2~16mm, 間隔增量1.0mm, 塑料盒裝。

ER25套裝筒夾(0級)(5微米)		
訂購編號 Order No.	型號 Model	內容
62177-00	ER25SET0	15個ER25筒夾(0級), ∅2~16mm, 間隔增量1.0mm, 塑料盒裝。

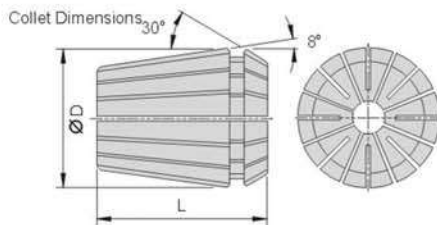
62178
ER32 筒夾 ER 32 Collets

 TOOLING SYSTEM
刀柄系列

D	L	夾持範圍	夾持間格
33	40	3.0~20.0	1.0

ER32(2級)		
訂購編號 Order No.	型號 Model	夾持 ∅
62178-202	ER320302	3.0~2.0
62178-203	ER320402	4.0~3.0
62178-204	ER320502	5.0~4.0
62178-205	ER320602	6.0~5.0
62178-206	ER320702	7.0~6.0
62178-207	ER320802	8.0~7.0
62178-208	ER320902	9.0~8.0
62178-209	ER321002	10.0~9.0
62178-210	ER321102	11.0~10.0
62178-211	ER321202	12.0~11.0
62178-212	ER321302	13.0~12.0
62178-213	ER321402	14.0~13.0
62178-214	ER321502	15.0~14.0
62178-215	ER321602	16.0~15.0
62178-216	ER321702	17.0~16.0
62178-217	ER321802	18.0~17.0
62178-218	ER321902	19.0~18.0
62178-219	ER322002	20.0~19.0

ER32(1級)		
訂購編號 Order No.	型號 Model	夾持 ∅
62178-102	ER320301	3.0~2.0
62178-103	ER320401	4.0~3.0
62178-104	ER320501	5.0~4.0
62178-105	ER320601	6.0~5.0
62178-106	ER320701	7.0~6.0
62178-107	ER320801	8.0~7.0
62178-108	ER320901	9.0~8.0
62178-109	ER321001	10.0~9.0
62178-110	ER321101	11.0~10.0
62178-111	ER321201	12.0~11.0
62178-112	ER321301	13.0~12.0
62178-113	ER321401	14.0~13.0
62178-114	ER321501	15.0~14.0
62178-115	ER321601	16.0~15.0
62178-116	ER321701	17.0~16.0
62178-117	ER321801	18.0~17.0
62178-118	ER321901	19.0~18.0
62178-119	ER322001	20.0~19.0

ER32(0級)(5微米)		
訂購編號 Order No.	型號 Model	夾持 ∅
62178-002	ER320300	3.0~2.0
62178-003	ER320400	4.0~3.0
62178-004	ER320500	5.0~4.0
62178-005	ER320600	6.0~5.0
62178-006	ER320700	7.0~6.0
62178-007	ER320800	8.0~7.0
62178-008	ER320900	9.0~8.0
62178-009	ER321000	10.0~9.0
62178-010	ER321100	11.0~10.0
62178-011	ER321200	12.0~11.0
62178-012	ER321300	13.0~12.0
62178-013	ER321400	14.0~13.0
62178-014	ER321500	15.0~14.0
62178-015	ER321600	16.0~15.0
62178-016	ER321700	17.0~16.0
62178-017	ER321800	18.0~17.0
62178-018	ER321900	19.0~18.0
62178-019	ER322000	20.0~19.0

62179
ER32 套裝筒夾(∅3~20mm 18個) ER 32 Collets Sets

ER32套裝筒夾(2級)		
訂購編號 Order No.	型號 Model	內容
62179-02	ER32SET2	18個ER32筒夾(2級), ∅3~20mm, 間隔增量1.0mm, 塑料盒裝。

ER32套裝筒夾(1級)		
訂購編號 Order No.	型號 Model	內容
62179-01	ER32SET1	18個ER32筒夾(1級), ∅3~20mm, 間隔增量1.0mm, 塑料盒裝。

ER32套裝筒夾(0級)(5微米)		
訂購編號 Order No.	型號 Model	內容
62179-00	ER32SET0	18個ER32筒夾(0級), ∅3~20mm, 間隔增量1.0mm, 塑料盒裝。

ER筒夾 ER Collets

62180

ER40

筒夾 ER 40 Collets

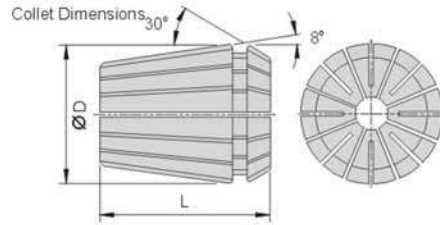

D	L	夾持範圍	夾持間格
41	46	4.0~26.0	1.0

ER40(2級)		
訂購編號 Order No.	型號 Model	夾持 Ø
62180-202	ER400402	4.0~3.0
62180-203	ER400502	5.0~4.0
62180-204	ER400602	6.0~5.0
62180-205	ER400702	7.0~6.0
62180-206	ER400802	8.0~7.0
62180-207	ER400902	9.0~8.0
62180-208	ER401002	10.0~9.0
62180-209	ER401102	11.0~10.0
62180-210	ER401202	12.0~11.0
62180-211	ER401302	13.0~12.0
62180-212	ER401402	14.0~13.0
62180-213	ER401502	15.0~14.0
62180-214	ER401602	16.0~15.0
62180-215	ER401702	17.0~16.0
62180-216	ER401802	18.0~17.0
62180-217	ER401902	19.0~18.0
62180-218	ER402002	20.0~19.0
62180-219	ER402102	21.0~20.0
62180-220	ER402202	22.0~21.0
62180-221	ER402302	23.0~22.0
62180-222	ER402402	24.0~23.0
62180-223	ER402502	25.0~24.0
62180-224	ER402602	26.0~25.0

ER40(1級)		
訂購編號 Order No.	型號 Model	夾持 Ø
62180-102	ER400401	4.0~3.0
62180-103	ER400501	5.0~4.0
62180-104	ER400601	6.0~5.0
62180-105	ER400701	7.0~6.0
62180-106	ER400801	8.0~7.0
62180-107	ER400901	9.0~8.0
62180-108	ER401001	10.0~9.0
62180-109	ER401101	11.0~10.0
62180-110	ER401201	12.0~11.0
62180-111	ER401301	13.0~12.0
62180-112	ER401401	14.0~13.0
62180-113	ER401501	15.0~14.0
62180-114	ER401601	16.0~15.0
62180-115	ER401701	17.0~16.0
62180-116	ER401801	18.0~17.0
62180-117	ER401901	19.0~18.0
62180-118	ER402001	20.0~19.0
62180-119	ER402101	21.0~20.0
62180-120	ER402201	22.0~21.0
62180-121	ER402301	23.0~22.0
62180-122	ER402401	24.0~23.0
62180-123	ER402501	25.0~24.0
62180-124	ER402601	26.0~25.0

ER40(0級)(5微米)		
訂購編號 Order No.	型號 Model	夾持 Ø
62180-002	ER400400	4.0~3.0
62180-003	ER400500	5.0~4.0
62180-004	ER400600	6.0~5.0
62180-005	ER400700	7.0~6.0
62180-006	ER400800	8.0~7.0
62180-007	ER400900	9.0~8.0
62180-008	ER401000	10.0~9.0
62180-009	ER401100	11.0~10.0
62180-010	ER401200	12.0~11.0
62180-011	ER401300	13.0~12.0
62180-012	ER401400	14.0~13.0
62180-013	ER401500	15.0~14.0
62180-014	ER401600	16.0~15.0
62180-015	ER401700	17.0~16.0
62180-016	ER401800	18.0~17.0
62180-017	ER401900	19.0~18.0
62180-018	ER402000	20.0~19.0
62180-019	ER402100	21.0~20.0
62180-020	ER402200	22.0~21.0
62180-021	ER402300	23.0~22.0
62180-022	ER402400	24.0~23.0
62180-023	ER402500	25.0~24.0
62180-024	ER402600	26.0~25.0

62181

ER40

套裝筒夾(Ø4~26mm 23個) ER 40 Collets Sets



ER40套裝筒夾(2級)		
訂購編號 Order No.	型號 Model	內容
62181-02	ER40SET2	23個ER40筒夾(2級), Ø4~26mm, 間隔增量1.0mm, 塑料盒裝。

ER40套裝筒夾(1級)		
訂購編號 Order No.	型號 Model	內容
62181-01	ER40SET1	23個ER40筒夾(1級), Ø4~26mm, 間隔增量1.0mm, 塑料盒裝。

ER40套裝筒夾(0級)(5微米)		
訂購編號 Order No.	型號 Model	內容
62181-00	ER40SET0	23個ER40筒夾(0級), Ø4~26mm, 間隔增量1.0mm, 塑料盒裝。

62182
ER50
筒夾 ER 50 Collets

D	L	夾持範圍	夾持間格
52	60	12.0~34.0	2.0

ER50(2級)

訂購編號 Order No.	型號 Model	夾持 ∅
62182-201	ER501202	12.0~10.0
62182-202	ER501402	14.0~12.0
62182-203	ER501602	16.0~14.0
62182-204	ER501802	18.0~16.0
62182-205	ER502002	20.0~18.0
62182-206	ER502202	22.0~20.0
62182-207	ER502402	24.0~22.0
62182-208	ER502502	25.0~23.0
62182-209	ER502602	26.0~24.0
62182-210	ER502802	28.0~26.0
62182-211	ER503002	30.0~28.0
62182-212	ER503202	32.0~30.0
62182-213	ER503402	34.0~32.0

62183
ER50
套裝筒夾(∅12~34mm 12個) ER 50 Collets Sets

ER50套裝筒夾(2級)

訂購編號 Order No.	型號 Model	內容
62183-02	ER50SET2	12個ER50筒夾(2級), ∅12~34mm, 間隔增量2.0mm, 塑料盒裝。

拉桿螺栓 Pull Studs

62232

PS

拉桿螺栓 Pull Studs

MAS-403



圖1

圖2

單位:mm

訂購編號 Order No.	型號 Model	圖示	$\phi D1$	$\phi D2$	$\phi D3$	$\phi D4$	L1	L2	α $\pm 15'$	G	W	最大旋緊扭矩 (Kgf-M)
62232-01	P30T-MAS1-G	1	11	7	16.5	12.5	43	23	45°	M12	13	2.0~2.5
62232-02	P30T-MAS2-G								60°			
62232-03	P30T-MAS3-G								90°			
62232-04	P40T-MAS1-G		15	10	23.0	17.0	60	35	45°	M16	19	6.0~8.0
62232-05	P40T-MAS2-G								60°			
62232-06	P40T-MAS3-G								90°			
62232-07	P50T-MAS1-G		23	17	38.0	25.0	85	45	45°	M24	30	20.0~25.0
62232-08	P50T-MAS2-G								60°			
62232-09	P50T-MAS3-G								90°			

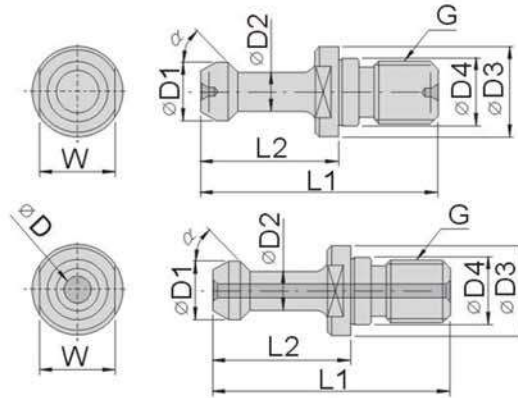
可提供無磨牙拉桿螺栓

訂購編號 Order No.	型號 Model	圖示	ϕD	$\phi D1$	$\phi D2$	$\phi D3$	$\phi D4$	L1	L2	α $\pm 15'$	G	W	最大旋緊扭矩 (Kgf-M)
62232-11	P40T-MAS1-G-H	2	4	15	10	23.0	17.0	60	35	45°	M16	19	6.0~8.0
62232-12	P40T-MAS2-G-H									60°			
62232-13	P40T-MAS3-G-H									90°			
62232-14	P50T-MAS1-G-H		6	23	17	38.0	25.0	85	45	45°	M24	30	20.0~25.0
62232-15	P50T-MAS2-G-H									60°			
62232-16	P50T-MAS3-G-H									90°			

注意:只能作軸向輕切削用。
可提供無磨牙拉桿螺栓

62234

PS

拉桿螺栓 Pull Studs

DIN69872A



圖1

圖2

單位:mm

訂購編號 Order No.	型號 Model	圖示	ϕD	$\phi D1$	$\phi D2$	$\phi D3$	$\phi D4$	L1	L2	G	W	最大旋緊扭矩 (Kgf-M)
62234-01	DIN69872A-SK30-G	1	-	13	9	17	13	44	24	M12	14	2.0~2.5
62234-02	DIN69872A-SK40-G		7.0	19	14	23	17	54	26	M16	19	6.0~8.0
62234-03	DIN69872A-SK50-G		11.5	28	21	36	25	74	34	M24	30	20.0~25.0
62234-04	DIN69872B-SK30-G	2	-	13	9	17	13	44	24	M12	14	2.0~2.5
62234-05	DIN69872B-SK40-G		7.0	19	14	23	17	54	26	M16	19	6.0~8.0
62234-06	DIN69872B-SK50-G		11.5	28	21	36	25	74	34	M24	30	20.0~25.0

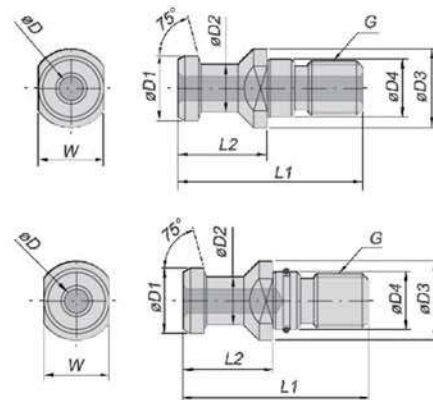
62236

PS

拉桿螺栓 Pull Studs

ISO7388/2B

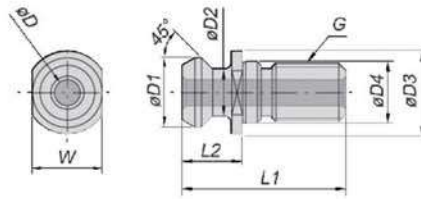

單位:mm

訂購編號 Order No.	型號 Model	ϕD	$\phi D1$	$\phi D2$	$\phi D3$	$\phi D4$	L1	L2	G	W	最大旋緊扭矩 (Kgf-M)
62236-01	ISO7388/2B-SK40-G	7.35	18.95	12.95	22.5	17	44.5	16.4	M16	19	6.0~8.0
62236-02	ISO7388/2B-SK50-G	11.50	29.1	19.6	37	25	65.5	25.4	M24	30	20.0~25.0

可提供無磨牙拉桿螺栓

62238

PS

拉桿螺栓 Pull Studs

MAZAK

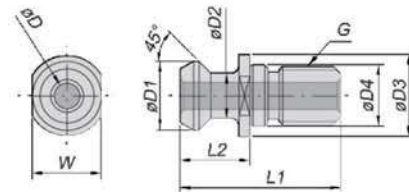

單位:mm

訂購編號 Order No.	型號 Model	ϕD	$\phi D1$	$\phi D2$	$\phi D3$	$\phi D4$	L1	L2	G	W	最大旋緊扭矩 (Kgf-M)
62238-01	MAZAK-BT40-G	7	18.8	12.45	22	17	44.1	19.1	M16	19	6.0~8.0
62238-02	MAZAK-BT50-G	10	28.95	20.83	37	25	65.2	25.2	M24	30	20.0~25.0

62240

PS

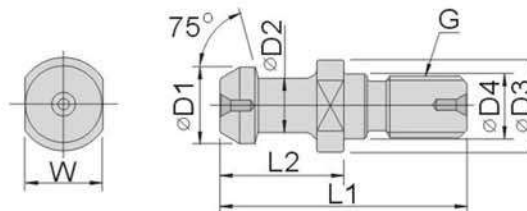
拉桿螺栓 Pull Studs

單位:mm

訂購編號 Order No.	型號 Model	$\phi D1$	$\phi D2$	$\phi D3$	$\phi D4$	L1	L2	G	W	最大旋緊扭矩 (Kgf-M)
62240	ISO-25-G	10	7	12	9	32	16	M8	10	0.9~1.2

62242

PS

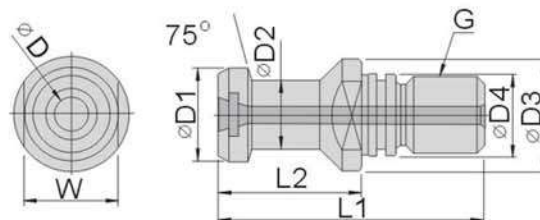
拉桿螺栓 Pull Studs

單位:mm

訂購編號 Order No.	型號 Model	ϕD	$\phi D1$	$\phi D2$	$\phi D3$	$\phi D4$	L1	L2	G	W	最大旋緊扭矩 (Kgf-M)
62242	JIS6339B-P40BH-G	7	19	14	23	17	54	29	M16	19	6.0~8.0

筒夾螺母 Collet Nut

62250~58

NH

筒夾螺母 Collet Nut

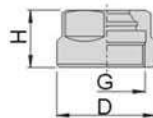

單位:mm

訂購編號 Order No.	型號 Model	規格	H	D	G	扳手編號
62250-01	NH-ER11A	ER 11-A	13	19	M14x0.75P	62260-01
62250-02	NH-ER16A	ER 16-A	18.7	28	M22x1.5P	62260-02
62250-03	NH-ER20A	ER 20-A	19	34	M25x1.5P	62260-03

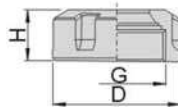

訂購編號 Order No.	型號 Model	規格	H	D	G	扳手編號
62252-01	NH-ER25B	ER 25-B	20	42	M32x1.5P	62262-01
62252-02	NH-ER32B	ER 32-B	24	50	M40x1.5P	62262-02
62252-03	NH-ER40B	ER 40-B	29	63	M50x1.5P	62262-03
62252-04	NH-ER50B	ER 50-B	35	78	M64x2.0P	62262-04

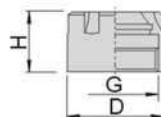

訂購編號 Order No.	型號 Model	規格	H	D	G	扳手編號
62254-01	NH-ER8M	ER 8-M	10.8	12	M10x0.75P	62264-01
62254-02	NH-ER11M	ER 11-M	12	16	M13x0.75P	62264-02
62254-03	NH-ER16M	ER 16-M	18	22	M19x1.0P	62264-03
62254-04	NH-ER20M	ER 20-M	19	28	M24x1.0P	62264-04
62254-05	NH-ER25M	ER 25-M	20	35	M30x1.0P	62264-05

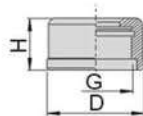

訂購編號 Order No.	型號 Model	規格	H	D	G	扳手編號
62256-01	NHR-SK6	SK6	20	31	M21.5xP1	
62256-02	NHR-SK10	SK10	16.5	20	M15xP1.0	62268-01
62256-03	NHR-SK16	SK16	30	41	M32xP1.5	62268-02

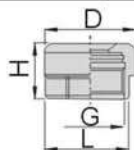

訂購編號 Order No.	型號 Model	規格	H	D	L	G	扳手編號
62258-01	NHS-SK6	SK6	-	19.5	17	-	62260-01
62258-02	NHS-SK10	SK10	17.5	29	25	M21.5xP1	62260-02
62258-03	NHS-SK16	SK16	24	41	36	M32xP1.5	-
62258-04	NHS-SK20	SK20	-	48	43	-	-
62258-05	NHS-SK25	SK25	-	50	50	-	-

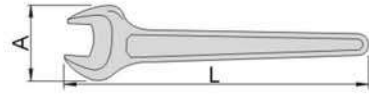
62260~68
WH
筒夾扳手 Collet Wrench

單位:mm

訂購編號 Order No.	型號 Model	規格	A	L
62260-01	WH-ER11A	ER11A	35	130
62260-02	WH-ER16A	ER16A	44	140
62260-03	WH-ER20A	ER20A	53	170

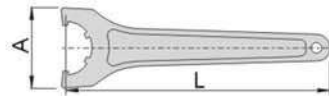

訂購編號 Order No.	型號 Model	規格	A	L
62262-01	WH-ER25B	ER25B	65	210
62262-02	WH-ER32B	ER32B	75	250
62262-03	WH-ER40B	ER40B	90	290
62262-04	WH-ER50B	ER50B	110	350



訂購編號 Order No.	型號 Model	規格	A	L
62264-01	WH-ER8M	ER8M	13	75
62264-02	WH-ER11M	ER11M	17	95
62264-03	WH-ER16M	ER16M	22.5	118
62264-04	WH-ER20M	ER20M	28	130
62264-05	WH-ER25M	ER25M	36.5	135

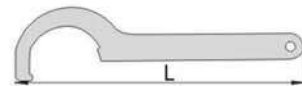

訂購編號 Order No.	型號 Model	規格	A	L
62266-01	WH-C20	C20	-	200
62266-02	WH-C25	C25	-	230
62266-03	WH-C32	C32	-	270
62266-04	WH-C42	C42	-	340

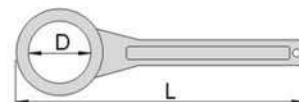

訂購編號 Order No.	型號 Model	規格	D	L
62268-01	WH-SK10	SK10/ER16	30	152.5
62268-02	WH-SK16	SK16	40	200
62268-03	WH-ER20	ER20	35	175
62268-04	WH-ER25	ER25	43	200
62268-05	WH-ER32	ER32	46	204

清潔棒 Taper Wiper

62270/75

W

BT型清潔棒 BT type Spindle Taper Wiper

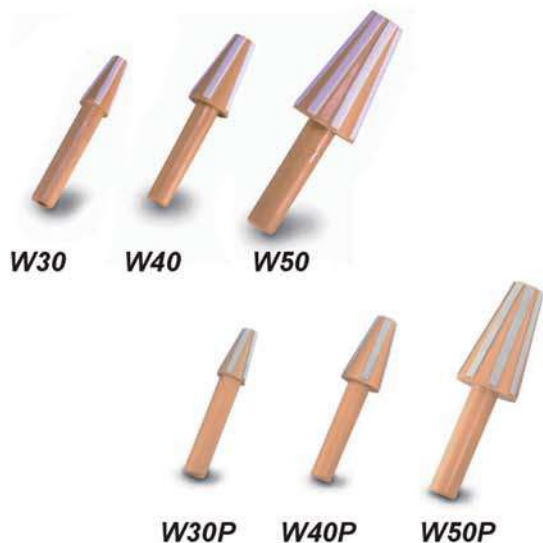

特點:

- ▶ 62270清潔棒的清潔片由不織布制成,可清理主軸內部,不傷主軸,延長主軸使用壽命。
- ▶ 62275清潔棒的清潔片由小羊皮制成,可清理主軸內部,不傷主軸,防止靜電產生,延長主軸使用壽命。

單位:mm

訂購編號 Order No.	型號 Model	BT斜度	清潔片	淨重	毛重
62270-30	W-30	#30	不織布	0.06kg	0.08kg
62270-40	W-40	#40		0.07kg	0.10kg
62270-50	W-50	#50		0.16kg	0.20kg
62275-30	W-30P	#30	羊毛皮	0.06kg	0.08kg
62275-40	W-40P	#40		0.07kg	0.10kg
62275-50	W-50P	#50		0.16kg	0.20kg

62290

W-HSK

清潔棒 Spindle Taper Wiper



特點:

- ▶ 清潔棒的清潔片由不織布制成,可清理主軸內部,不傷主軸,延長主軸使用壽命。

單位:mm

訂購編號 Order No.	型號 Model	規格	清潔片	淨重	毛重
62290-40	W-HSK40A	HSK40	不織布	0.08kg	0.10kg
62290-50	W-HSK50H	HSK50/HSK63F		0.08kg	0.12kg
62290-63	W-HSK63H	HSK63		0.10kg	0.13kg
62290-100	W-HSK100H	HSK100		0.50kg	0.70kg

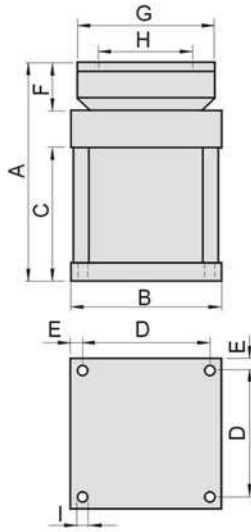
62315
LDB
鎖刀座 Tool Tightening Fixture

特點:

- ▶ 操作簡單,可以很容易的鎖定刀軸。
- ▶ 置刀架所使用之材質及外形結構設計合理,有效保護刀柄。
- ▶ 為防止刀柄碰傷,使用時輕拿輕放,用后妥善保管。
- ▶ 本體為鑄鐵材料,操作避免敲擊。

單位:mm

訂購編號 Order No.	型號 Model	規格	A	B	C	D	E	F	G	H	I	淨重	毛重
62315-50	LDB-HSK50	HSK50	139.5	100	89	84	8	25.5	77.5	50	7	2.3kg	2.5kg
62315-63	LDB-HSK63	HSK63	145.5	100	89	84	8	31.5	96.5	63	7	3.0kg	3.2kg

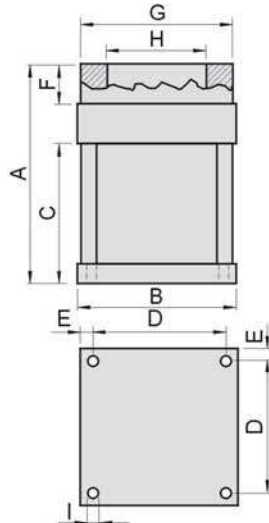
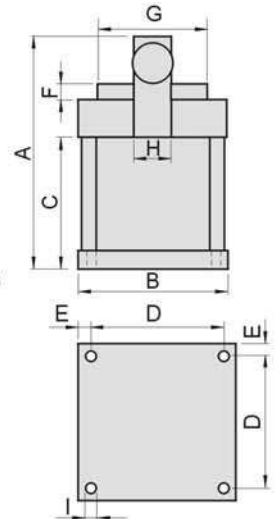
62320/25
LDI/LDAC
鎖刀座 Tool Tightening Fixture

62320

62325

單位:mm

訂購編號 Order No.	型號 Model	A	B	C	D	E	F	G	H	I	淨量	毛重
62320-01	LD-HSK32I	141	100	89	84	8	27	80	32	7	2.8kg	3.0kg
62320-02	LD-HSK40I	141	100	89	84	8	27	80	40	7	2.7kg	2.9kg
62320-03	LD-HSK50I	147	100	89	84	8	33	95	50	7	2.8kg	3.0kg
62320-04	LD-HSK63I	139	100	89	84	8	25	96	63	7	2.9kg	3.1kg
62325-01	LD-HSK63AC	157	100	89	84	8	12	76.5	25	7	2.8kg	3.0kg
62325-02	LD-HSK100AC	208	125	115	101	12	12	115	25	9	6.0kg	7.0kg

鎖刀座 Tool Tightening Fixture

62330

LDA

鎖刀座 Tool Tightening Fixture

特點:

- ▲ 操作簡單,可以很容易的鎖定刀軸。
- ▲ 置刀架所使用之材質及外形結構設計合理,有效保護刀柄。
- ▲ 為防止刀柄碰傷,使用時輕拿輕放,用后妥善保管。
- ▲ 本體為鑄鐵材料,操作避免敲擊。

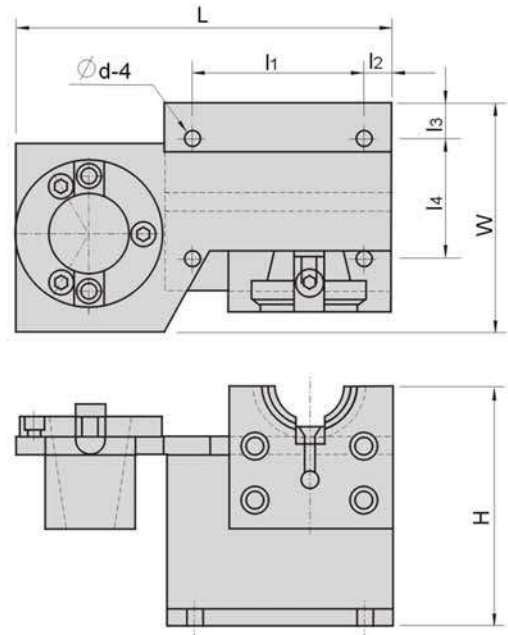

單位:mm

訂購編號 Order No.	型號 Model	L	l ₁	l ₂	l ₃	l ₄	H	W	淨量	毛重
62330-01	LD-BT30A	210	95	10	15	67	130	100	3.6kg	3.7kg
62330-02	LD-BT40A	210	95	10	15	67	130	100	3.7kg	3.9kg
62330-03	LD-BT50A	275	113	20	24	105	200	150	11.0kg	11.4kg
62330-04	LD-DIN40A	210	95	10	15	67	130	100	3.6kg	3.8kg
62330-05	LD-DIN50A	275	113	20	24	105	200	150	10.8kg	11.2kg
62330-06	LD-CAT40A	210	95	10	15	67	130	100	3.6kg	3.8kg
62330-07	LD-CAT50A	275	113	20	24	105	200	150	10.8kg	11.2kg



特點:

鎖刀座可任意替換

壓住本體右側之壓閂,可輕易的進行鎖刀座與本體之結合或拆卸。

鎖刀座可360°旋轉

壓住本體之定位柱,可輕易的讓鎖刀座做(8個45°定位)旋轉。

本體底座採用M10X40mm螺栓
固定於工作臺面或用4支M12螺栓
由工作臺面底部反鎖固定



鎖刀座本體

訂購編號 Order No.	型號 Model	重量 N.W.
62340-01	TCP-150	6kg



鎖刀座

訂購編號 Order No.	型號 Model	重量 N.W.
62340-02	TCP-BT30	2.3kg
62340-03	TCP-BT40	2.8kg
62340-04	TCP-BT50	4.8kg
62340-05	TCP-HSK-A-40	3.3kg
62340-06	TCP-HSK-A-63	2.3kg
62340-07	TCP-HSK-A-80	3.5kg
62340-08	TCP-HSK-A-100	3.8kg
62340-09	TCP-HSK-E-25	2.3kg
62340-10	TCP-HSK-E-32	2.5kg
62340-11	TCP-HSK-E-40	2.8kg
62340-12	TCP-HSK-E-50	3.0kg
62340-13	TCP-HSK-F-63	3.2kg

鑽夾頭 Drill Chuck

63040

BT/JT

斜柄鑽帽芯軸 NC Drill Chuck Adaptor-Mas BT30/40/50 Shank

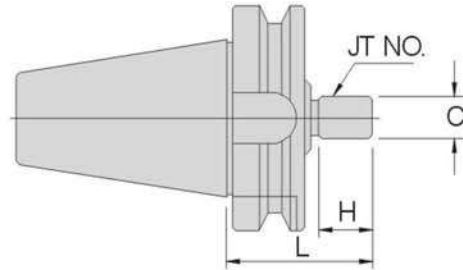

單位:mm

訂購編號 Order No.	型號 Model	Taper NO.	C	H	L	重量 N.W.
63040-01	BT30-JT6	JT6	17.17	24	45	0.44kg
63040-02	BT40-JT6	JT6	17.17	24	45	1.16kg
63040-03	BT50-JT6	JT6	17.17	24	45	3.85kg
63040-04	BT50-JT6L	JT6	17.17	24	105	4.88kg

63050

APU/JT

自鎖式鑽夾頭 Keyless Drill Chuck

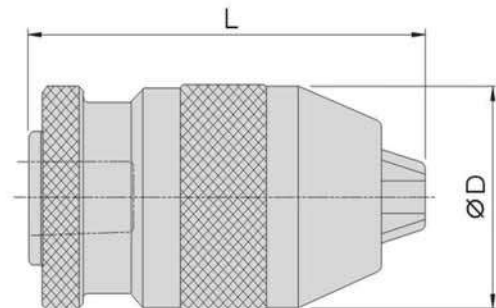

單位:mm

訂購編號 Order No.	型號 Model	Capacity	Taper	D	L		重量 N.W.
					open	closed	
63050-01	APU08-JT1	0-8	JT1	38	68	76	0.39kg
63050-02	APU10-JT2	0-10	JT2	43	80	92	0.61kg
63050-03	APU13-JT6	0-13	JT6	49	90	102	0.92kg
63050-04	APU16-JT6	3-16	JT6	55	97	110	1.20kg

63070
MDR
連柄一體式鑽夾頭(特重型系列)
Arbor Type Special Heavy Duty Model Drill Chuck

附有夾頭柄結構之設計,使得它更適於銑床及綜合切削機且有更趨於完美之表現。精密的機械工學和堅固耐用的組成確保了耐力及精度。



訂購編號 Order No.	型號 Model	規格	夾持力		錐柄組 接型式	長度			重量 N.W.
			公制	英制		A	B	D 外徑	
63070-01	MT2-8S	8S	0.3-8	1/64-5/16	MT2	142	61	37	0.4kg
63070-02	MT2-10S	10S	0.3-10	1/64-3/8	MT2	151	70	43	0.7kg
63070-03	MT3-13S	13S	0.3-13	1/64-1/2	MT3	180	81	50	1.14kg
63070-04	MT2-13S	13S	0.3-13	1/64-1/2	MT2	162	81	50	1.01kg
63070-05	MT4-13S	13S	0.3-13	1/64-1/2	MT4	206	81	50	1.49kg
63070-06	MT3-16S	16S	3-16	1/8-5/8	MT3	186	85	58	1.45kg
63070-07	MT4-16S	16S	3-16	1/8-5/8	MT4	212	85	58	1.77kg

訂購編號 Order No.	型號 Model	規格	夾持力		錐柄組 接型式	長度			重量 N.W.
			公制	英制		A	B	D 外徑	
63070-08	D12-3S	3S	0.3-3	1/64-1/8	D12	88.5	38.5	24	0.14kg
63070-09	D16-6S	6S	0.3-6.5	1/64-1/4	D16	104	54	33	0.34kg
63070-10	D20-8S	8S	0.3-8	1/64-5/16	D20	121	61	37	0.51kg
63070-11	D20-13S	13S	0.3-13	1/64-1/2	D20	141	81	50	1.03kg
63070-12	D25-13S	13S	0.3-13	1/64-1/2	D25	160	81	50	1.19kg
63070-13	D32-13S	13S	0.3-13	1/64-1/2	D32	162	81	50	1.41kg
63070-14	D20-16S	16S	3-16	1/8-5/8	D20	145	85	58	1.33kg
63070-15	D25-16S	16S	3-16	1/8-5/8	D25	165	85	58	1.48kg
63070-16	D32-16S	16S	3-16	1/8-5/8	D32	167	85	58	1.70kg

訂購編號 Order No.	型號 Model	規格	夾持力		錐柄組 接型式	長度			重量 N.W.
			公制	英制		A	B	D 外徑	
63070-17	R8-13S	13S	0.3-13	1/64-1/2	R8	182	81	50	1.26kg
63070-18	R8-16S	16S	3-16	1/8-5/8	R8	188	85	58	1.53kg

鑽夾頭同心度檢驗表

單位:mm

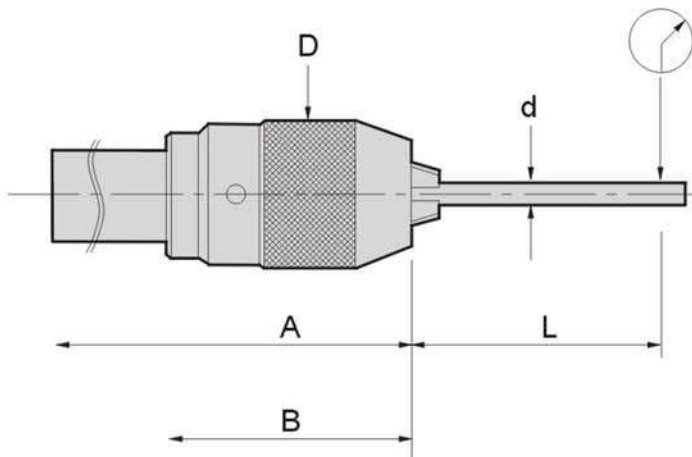

夾持力	∅d	L	最大同心度
3S	1.5	30	0.05
	3		
6S	3	35	0.05
	4		
	6		
8S	4	35	0.05
	6		
	8	50	
10S	5	35	0.05
	6		
	10	58	
13S	6	55	0.05
	10		
	13	75	
16S	6	55	0.05
	10		
	16	80	

鑽夾頭 Drill Chuck

63080

NT/CHU

直結式鑽夾頭 CNC Drill Chuck

鑽夾頭
DRILL CHUCK



特點:

ISO

- ▶ 適用於傳統銑床或其他提供NT主軸介面之工作母機作鑽孔加工。
- ▶ 比普通夾頭多3倍的夾持力。
- ▶ 鑽頭不會鬆脫或掉落。
- ▶ 比普通夾頭多2倍精準。
- ▶ 可替換式的夾頭。

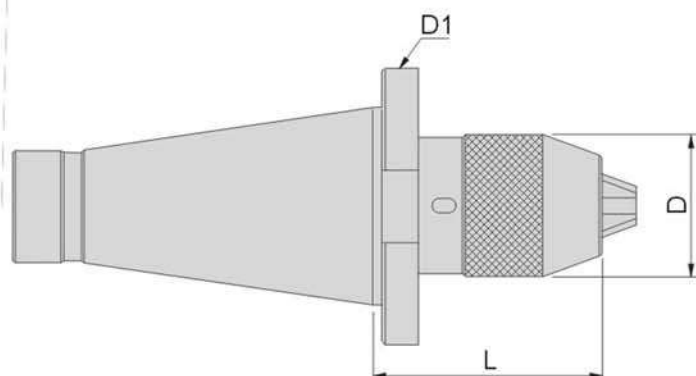

63120 HW 勾扳手 Hook Wrench

訂購編號 Order No.	型號 Model	尺寸	重量 N.W.
63120-01	HW08	8mm	0.1kg
63120-02	HW13	13mm	0.16kg
63120-03	HW16	16mm	0.25kg



單位:mm

訂購編號 Order No.	型號 Model	L	ØD	ØD1	螺紋尺寸
63080-01	NT30xCHU08-80A	80	37	49	1/2"W12
63080-02	NT30xCHU08-80B	80	37	49	M12x1.75P
63080-03	NT30xCHU08-80C	80	37	49	1/2"UNC13
63080-04	NT30xCHU13-100A	100	50	49	1/2"W12
63080-05	NT30xCHU13-100B	100	50	49	M12x1.75P
63080-06	NT30xCHU13-100C	100	50	49	1/2"UNC13
63080-07	NT40xCHU08-80A	80	37	63	5/8"W11
63080-08	NT40xCHU08-80B	80	37	63	M16x2.0P
63080-10	NT40xCHU13-95B	95	50	63	M16x2.0P
63080-12	NT40xCHU16-105B	105	57	63	M16x2.0P
63080-13	NT50xCHU13-85A	85	50	97.5	1"W8
63080-14	NT50xCHU13-85B	85	50	97.5	M24x3.0p
63080-15	NT50xCHU16-100A	100	57	97.5	1"W8
63080-16	NT50xCHU16-100B	100	57	97.5	M24x3.0P

63090
BT/CHU
直結式鑽夾頭 CNC Drill Chuck

特點:

- ▲ 適用於傳統銑床或其他提供NT主軸介面之工作母機作鑽孔加工。
- ▲ 比普通夾頭多3倍的夾持力。
- ▲ 鑽頭不會鬆脫或掉落。
- ▲ 比普通夾頭多2倍精準。
- ▲ 可替換式的夾頭。

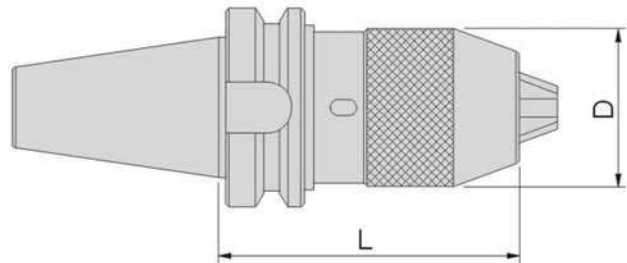
 鑽夾頭
DRILL CHUCK

63120 HW 勾扳手 Hook Wrench

訂購編號 Order No.	型號 Model	尺寸	重量 N.W.
63120-01	HW08	8mm	0.1kg
63120-02	HW13	13mm	0.16kg
63120-03	HW16	16mm	0.25kg



單位:mm

訂購編號 Order No.	型號 Model	夾持範圍	L	ØD	重量 N.W.
63090-01	BT30xCHU08-80	0-8	80	36	0.8kg
63090-02	BT30xCHU13-105	1-13	105	51	1.6kg
63090-03	BT40xCHU08-90	0-8	90	36	1.4kg
63090-04	BT40xCHU13-90	1-13	90	51	1.8kg
63090-05	BT40xCHU16-115	1-16	115	58	2.3kg
63090-06	BT50xCHU13-125	1-13	125	51	4.7kg
63090-07	BT50xCHU13-185	1-13	185	51	5.4kg
63090-08	BT50xCHU16-185	1-16	185	58	6.6kg

鑽夾頭 Drill Chuck

63120

HW

勾扳手 Hook Wrench

鑽夾頭
DRILL CHUCK

訂購編號 Order No.	型號 Model	尺寸	重量 N.W.
63120-01	HW08	8mm	0.1kg
63120-02	HW13	13mm	0.16kg
63120-03	HW16	16mm	0.25kg



一體鑽夾頭操作說明



鎖緊



松开



順時針方向



逆時針方向



63150
JIS B6339/MAS 406 BT
一體式鑽夾頭 Integrated Drill Chuck

特點:

- ▶ 設計功能--能增強鑽夾頭的堅固性及精準性，於使用綜合加工中心機的換刀系統。
- ▶ 刀柄和鑽夾頭結合為一體。即使是作重切削的加工，鑽夾頭也不會脫落。
- ▶ 即使機器主軸立即停止，刀具也不會因此脫落。
- ▶ 超過長時間的使用，此夾頭仍保持高精度。

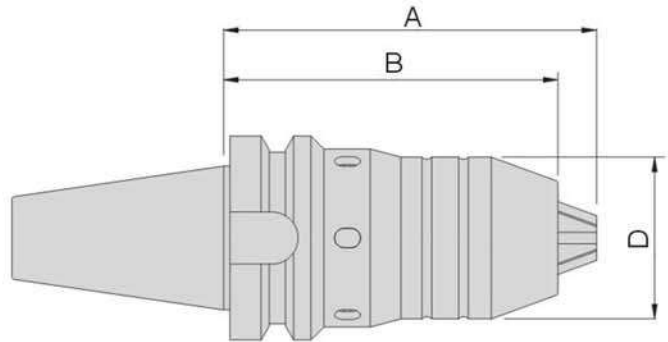
 鑽夾頭
DRILL CHUCK

扳手請參照P F93

單位:mm

訂購編號 Order No.	型號 Model	組接型式	尺寸	夾持量		規格		
				公制	英制	A 關	B 開	D 外徑
63150-01	BT30-8	BT30	8mm	0-8	0-5/16	92	83	37.5
63150-02	BT30-13	BT30	13mm	0-13	0-1/2	115	102	50
63150-03	BT40-8	BT40	8mm	0-8	0-5/16	96	87	37.5
63150-04	BT40-13	BT40	13mm	0-13	0-1/2	115	102	50
63150-05	BT40-16	BT40	16mm	3-16	1/8-5/8	121.5	108.5	57
63150-06	BT50-8	BT50	8mm	0-8	0-5/16	106	98	37.5
63150-07	BT50-13	BT50	13mm	0-13	0-1/2	126.2	115.5	50
63150-08	BT50-16	BT50	16mm	3-16	1/8-5/8	132.5	119.5	57

攻牙器 Tap Chuck

63500

BT/WFE

快換式絲攻刀桿 (伸縮緩沖加長型)

Quick Change Tapping Chucks With Length Compensation/Extra Length



特點:

- ▶ 快換式絲攻連接桿
- ▶ 緩沖可預防絲攻在攻牙時斷落

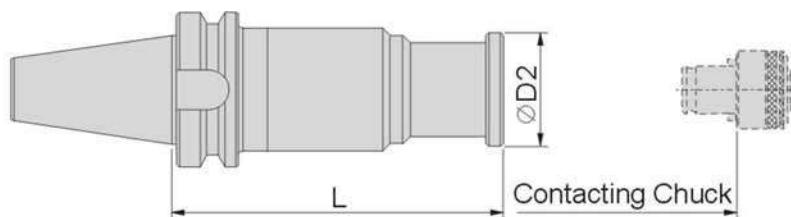

單位:mm

訂購編號 Order No.	型號 Model	攻牙能力	L	ØD2	適用筒夾
63500-01	BT40-WFE12-135	M3~M12	135	36	TC312 TC312B
63500-02	BT40-WFE12-165	M3~M12	165	36	TC312 TC312B
63500-03	BT50-WFE12-135	M3~M12	135	36	TC312 TC312B
63500-04	BT50-WFE12-165	M3~M12	165	36	TC312 TC312B
63500-05	BT50-WFE12-195	M3~M12	195	36	TC312 TC312B

※特制品可依客戶需求訂制
※絲攻筒夾需另購

63510
BT/WF
快換式絲攻刀桿 (伸縮緩沖型)
Quick Change Tapping Chucks With Length Compensation

特點:

- ▶ 快換式絲攻連接桿
- ▶ 緩沖可預防絲攻在攻牙時斷落

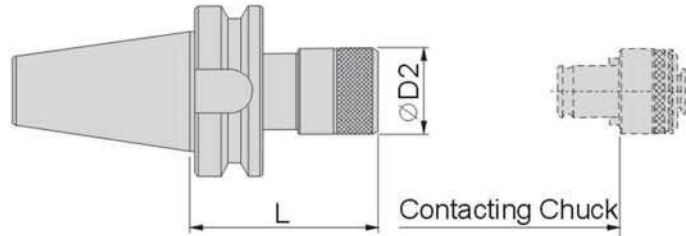

單位:mm

訂購編號 Order No.	型號 Model	攻牙能力	L	ØD2	適用筒夾
63510-01	BT30-WF12	M3~M12	70	36	TC312 TC312B
63510-02	BT40-WF12	M3~M12	70	36	TC312 TC312B
63510-03	BT50-WF12	M3~M12	85	36	TC312 TC312B
63510-04	BT30-WF20	M8~M20	95	50	TC820 TC820B
63510-05	BT40-WF20	M8~M20	95	50	TC820 TC820B
63510-06	BT50-WF20	M8~M20	105	50	TC820 TC820B
63510-07	BT40-WF33	M14~M33	160	78	TC1433 TC1433B
63510-08	BT50-WF33	M14~M33	145	78	TC1433 TC1433B

※特制品可依客户需求訂制

※絲攻筒夾需另購

63520
D/WF
快換式絲攻刀桿 (伸縮緩沖型)
Quick Change Tapping Chucks With Length Compensation

特點:

- ▶ 直柄型-筒夾專用
- ▶ 快換式絲攻連接桿
- ▶ 緩沖可預防絲攻在攻牙時斷落

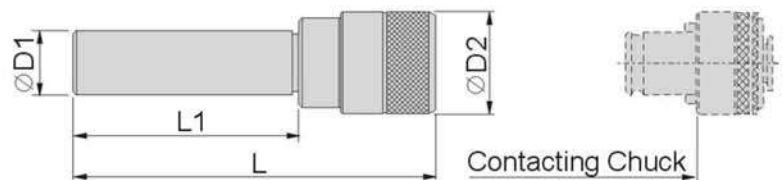

單位:mm

訂購編號 Order No.	型號 Model	攻牙能力	L	L1	ØD1	ØD2	適用筒夾
63520-01	D20-WF12	M3~M12	113	70	20	32	TC312
63520-02	D32-WF12	M3~M12		70	32	32	TC312B
63520-03	D20-WF20	M8~M20		70	20	50	TC820
63520-04	D32-WF20	M8~M20	145	70	32	50	TC820B
63520-05	D32-WF33	M14~M33	185	70	32	73	TC1433B

※特制品可依客户需求訂制

※絲攻筒夾需另購

 TAP CHUCK
攻牙器

攻牙器 Tap Chuck

63600

TC

快換式絲攻夾頭(扭力型)

Quick Change Tap Collets With Overload Clutch

特點:

▲ 扭力型絲攻設計,可預防絲攻在攻牙時斷裂。

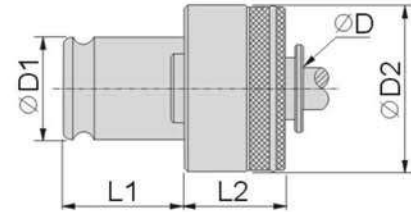

訂購編號 Order No.	TC 312 JIS Tap			絲攻尺寸		攻牙能力	L1 (mm)	L2 (mm)	ØD1 (mm)	ØD2 (mm)
				ØD 柄徑	□四方孔					
63600-01	M2			3.0	2.5	M3~M14	22	25	19	32
63600-02	M3		#5.#6	4.0	3.2					
63600-03	M4	M4.5	#8	5.0	4.0					
63600-04	M5	M5.5	#10	5.5	4.5					
63600-05	M6		UNC 1/4	6.0	4.5					
63600-06			UNC 5/16	6.1	5.0					
63600-07	M8	M7		6.2	5.0					
63600-08	M10	M9	UNC 3/8	7.0	5.5					
63600-09		M11	UNC 7/16	8.0	6.0					
63600-10	M12			8.5	6.5					
63600-11			UNC 1/2	9.0	7.0					
63600-12	M14	M15	UNC 9/16	10.5	8.0					

訂購編號 Order No.	TC 820 JIS Tap			絲攻尺寸		攻牙能力	L1 (mm)	L2 (mm)	ØD1 (mm)	ØD2 (mm)
				ØD 柄徑	□四方孔					
63600-13	M5	M5.5	#10	5.5	4.5	M8~M24	36	30.5	31	50
63600-14	M6		UNC 1/4	6.0	4.5					
63600-15			UNC 5/16	6.1	5.0					
63600-16	M8	M7		6.2	5.0					
63600-17	M10	M9	UNC 3/8	7.0	5.5					
63600-18		M11	UNC 7/16	8.0	6.0					
63600-19	M12			8.5	6.5					
63600-20			UNC 1/2	9.0	7.0					
63600-21	M14	M15	UNC 9/16	10.5	8.0					
63600-22			UNC 5/8	12.0	9.0					
63600-23	M16			12.5	10.0					
63600-24		M17		13.0	10.0					
63600-25	M18		UNC 3/4	14.0	11.0					
63600-26	M20			15.0	12.0					
63600-27	M22		UNC 7/8	17.0	13.0					
63600-28	M24	M25		19.0	15.0					

訂購編號 Order No.	TC1433 JIS Tap			絲攻尺寸		攻牙能力	L1 (mm)	L2 (mm)	ØD1 (mm)	ØD2 (mm)
				ØD 柄徑	□四方孔					
63600-29	M14	M15	UNC 9/16	10.5	8.0	M14~M36	56	45	48	72
63600-30			UNC 5/8	12.0	9.0					
63600-31	M16			12.5	10.0					
63600-32		M17		13.0	10.0					
63600-33	M18		UNC 3/4	14.0	11.0					
63600-34	M20			15.0	12.0					
63600-35	M22		UNC 7/8	17.0	13.0					
63600-36	M24	M25		19.0	15.0					
63600-37	M27	M26	UNC 1	20.0	15.0					
63600-38	M28			21.0	17.0					
63600-39			UNC 1 1/8	22.0	17.0					
63600-40	M30			23.0	17.0					
63600-41	M32		UNC 1 1/4	24.0	19.0					
63600-42	M33			25.0	19.0					
63600-43	M35	M34	UNC 1 3/8	26.0	21.0					
63600-44	M36			28.0	21.0					

※特制品可依客户需求訂制

63610
TC
快換式絲攻夾頭(扭力型DIN 371)
Quick Change Tap Collets With Overload Clutch DIN 371

 攻牙器
TAP CHUCK

特點:

▲ 扭力型絲攻設計,可預防絲攻在攻牙時斷裂。

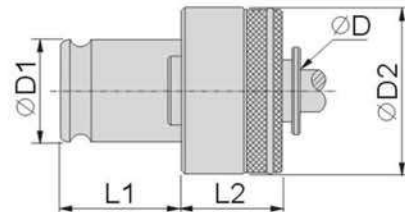

訂購編號 Order No.	TC 312 DIN371 Tap	絲攻尺寸		攻牙能力	L1 (mm)	L2 (mm)	ØD1 (mm)	ØD2 (mm)
		ØD 柄徑	□ 四方孔					
63610-01	M1~M1.8	2.5	2.1	M3~M14	22	25	19	32
63610-02	M2~2.5	2.8	2.1					
63610-03	M3	3.5	2.7					
63610-04	M3.5	4.0	3.0					
63610-05	M4	4.5	3.4					
63610-06	M4.5	6.0	4.9					
63610-07	M5	6.0	4.9					
63610-08	M6	6.0	4.9					
63610-09	M8	8.0	6.2					
63610-10	M10	10.0	8.0					

訂購編號 Order No.	TC 820 DIN371 Tap	絲攻尺寸		攻牙能力	L1 (mm)	L2 (mm)	ØD1 (mm)	ØD2 (mm)
		ØD 柄徑	□ 四方孔					
63610-11	M5	6.0	4.9	M8~M24	36	30.5	31	50
63610-12	M6	6.0	4.9					
63610-13	M8	8.0	6.2					
63610-14	M10	10.0	8.0					

※特制品可依客户需求訂制

攻牙器 Tap Chuck

63620

TC

快換式絲攻夾頭(扭力型DIN 376)

Quick Change Tap Collets With Overload Clutch DIN 376

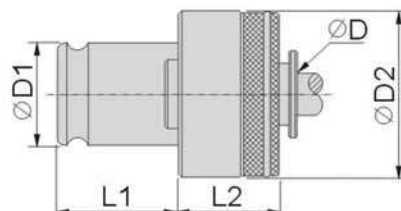

訂購編號 Order No.	TC312 DIN376 Tap	絲攻尺寸		攻牙能力	L1 (mm)	L2 (mm)	ØD1 (mm)	ØD2 (mm)
		ØD 柄徑	□四方孔					
63620-01	M3.5	2.5	2.1	M3~M14	22	25	19	32
63620-02	M4	2.8	2.1					
63620-03	M4.5	3.5	2.7					
63620-04	M5	3.5	2.7					
63620-05	M6	4.5	3.4					
63620-06	M7	5.5	4.3					
63620-07	M8	6.0	4.9					
63620-08	M10	7.0	5.5					
63620-09	M12	9.0	7.0					
63620-10	M14	11.0	9.0					
訂購編號 Order No.	TC820 DIN376 Tap	絲攻尺寸		攻牙能力	L1 (mm)	L2 (mm)	ØD1 (mm)	ØD2 (mm)
		ØD 柄徑	□四方孔					
63620-11	M8	6.0	4.9	M8~M24	36	30.5	31	50
63620-12	M10	7.0	5.5					
63620-13	M12	9.0	7.0					
63620-14	M14	11.0	9.0					
63620-15	M16	12.0	9.0					
63620-16	M18	14.0	11.0					
63620-17	M20	16.0	12.0					
63620-18	M22	18.0	14.5					
63620-19	M24	18.0	14.5					
訂購編號 Order No.	TC1433 DIN376 Tap	絲攻尺寸						
		ØD 柄徑	□四方孔					
63620-20	M14	11.0	9.0	M14~M36	56	45	48	72
63620-21	M16	12.0	9.0					
63620-22	M18	14.0	11.0					
63620-23	M20	16.0	12.0					
63620-24	M22	18.0	14.5					
63620-25	M24	18.0	14.5					
63620-26	M27	20.0	16.0					
63620-27	M30	22.0	18.0					
63620-28	M33	25.0	20.0					
63620-29	M36	28.0	22.0					

※特制品可依客户需求訂制

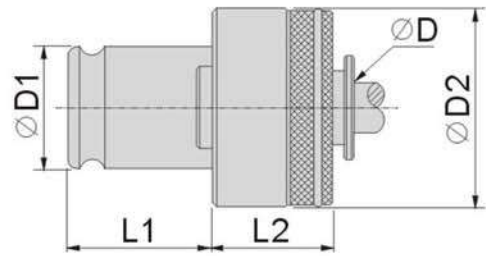
63630
TC
快換式絲攻夾頭(扭力型ISO 529)
Quick Change Tap Collets With Overload Clutch ISO 529

 攻牙器
TAP CHUCK

訂購編號 Order No.	TC312 ISO 529 Tap	絲攻尺寸		攻牙能力	L1 (mm)	L2 (mm)	ØD1 (mm)	ØD2 (mm)
		ØD 柄徑	□ 四方孔					
63630-01	M1~M2	2.5	2.0	M3~M14	22	25	19	32
63630-02	M2.2~M2.5	2.8	2.24					
63630-03	M3	3.15	2.5					
63630-04	M3.5	3.55	2.8					
63630-05	M4	4.0	3.15					
63630-06	M4.5	4.5	3.55					
63630-07	M5	5.0	4.0					
63630-08	M6	6.3	5.0					
63630-09	M7	7.1	5.6					
63630-10	M8	8.0	6.3					
63630-11	M9	9.0	7.1					
63630-12	M10	10.0	8.0					
訂購編號 Order No.	TC 820 ISO529 Tap	絲攻尺寸		攻牙能力	L1 (mm)	L2 (mm)	ØD1 (mm)	ØD2 (mm)
		ØD 柄徑	□ 四方孔					
63630-13	M6	6.3	5.0	M8~M24	36	30.5	31	50
63630-14	M7	7.1	5.6					
63630-15	M8	8.0	6.3					
63630-16	M9	9.0	7.1					
63630-17	M10	10.0	8.0					

※特制品可依客户需求訂制