

# 模組化並列式虎鉗系列

---



# MKS

# C01-C20

**MKS**

## 模組化並列式虎鉗應用實例

### Modular Clamping System Applications

用於立柱(可選搭虎鉗應用)

依立柱尺寸不同可自行選擇適合的虎鉗

Tombstone application: choose appropriate MKS model according to processing needs.

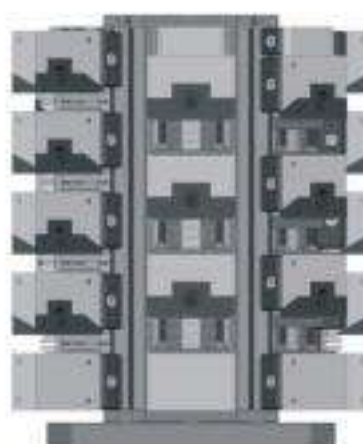
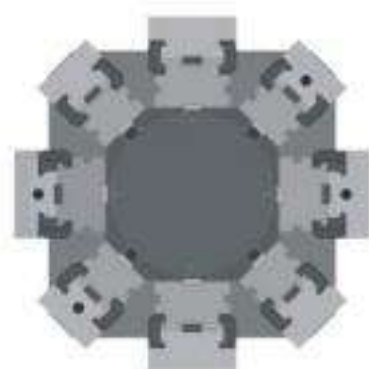

用於第四軸(可選搭虎鉗應用)

依第四軸分度盤中心高不同可自行調整虎鉗夾持的高度

4th-axis rotary table application: depending on the centre height of the index plate choosing the appropriate MKS model.

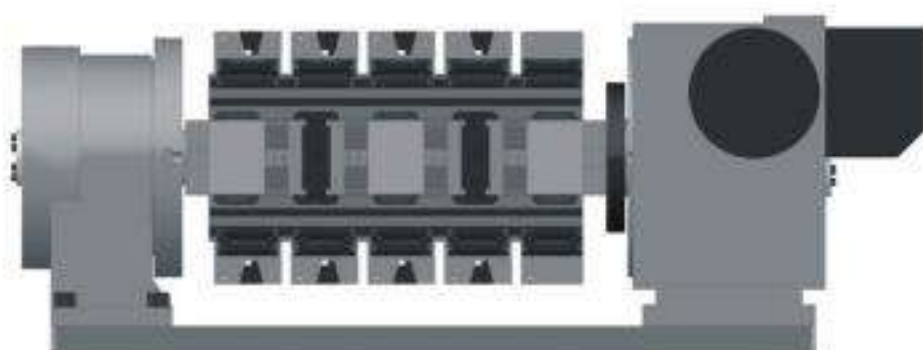

**MKS**

# 模組化並列式虎鉗應用實例

## Modular Clamping System Applications

虎鉗搭配3"三爪夾頭(運用於60寬的基座上)  
With optional 3" 3-Jaw Chuck(on 60mm wide base)



虎鉗搭配4"三爪夾頭(運用於80寬的基座上)  **C12**  
With optional 4" 3-Jaw Chuck(on 80mm wide base)



虎鉗搭配5"三爪夾頭(運用於100寬的基座上)  **C12**  
With optional 5" 3-Jaw Chuck(on 100mm wide base)

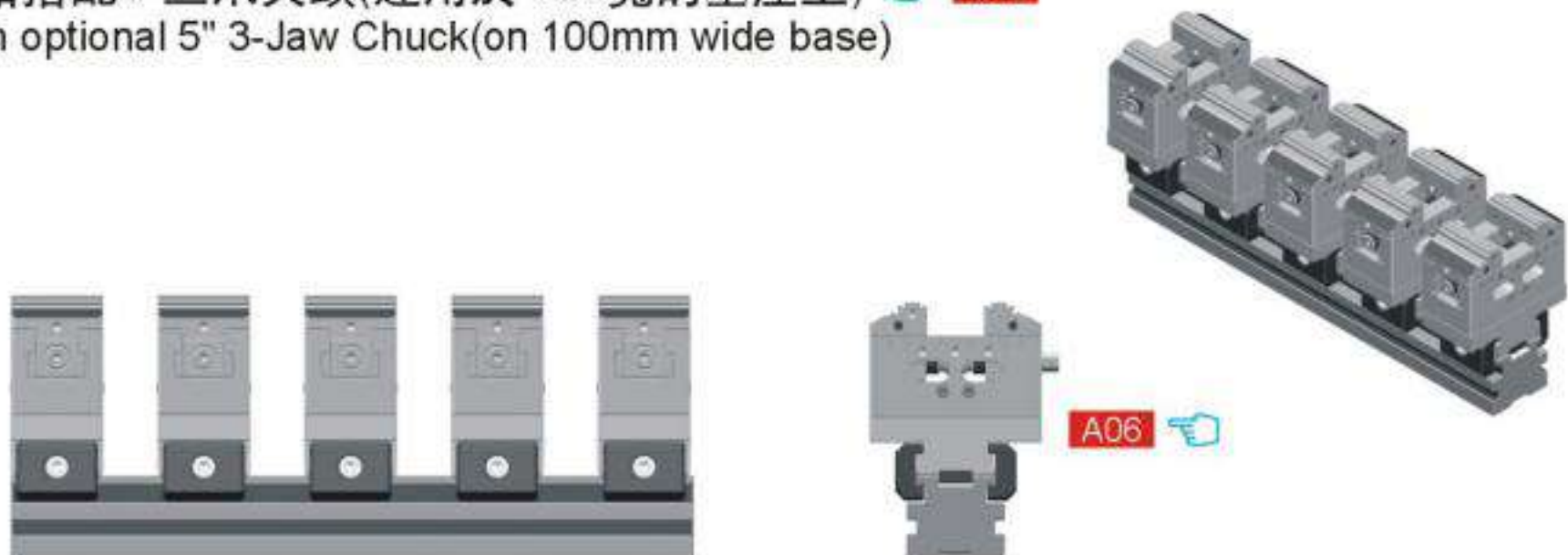

虎鉗搭配精密快速求心虎鉗(虎鉗基座透過連接板可用於60寬的基座)  **C12**  
With optional self-centering vise on flanges (on 60mm wide base)



# MKS-A / MKS-B

## 模組化並列式虎鉗應用實例 Modular Clamping System Applications

MKS-A(單向平行夾持)  
(One side lockdown)

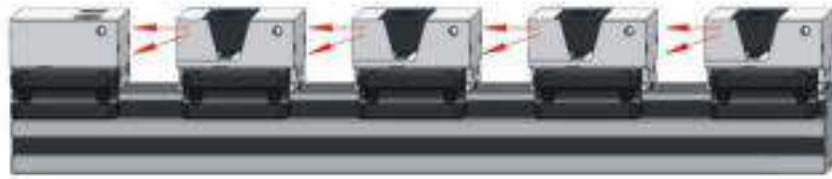

MKS-B(雙向平行夾持)  
(Dual sides lockdown)

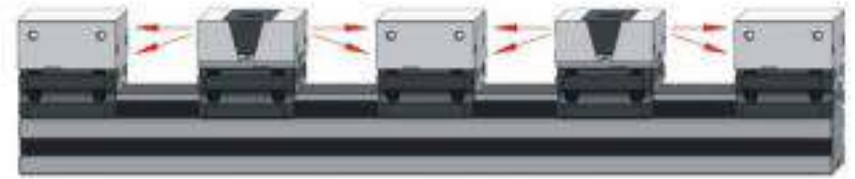

(MKS型適用於立式機床)  
(on vertical machining center applications)

詳細請參閱 Refer to Page

C05、C07

MKS-A



等距夾持 Equidistant clamping

MKS-B

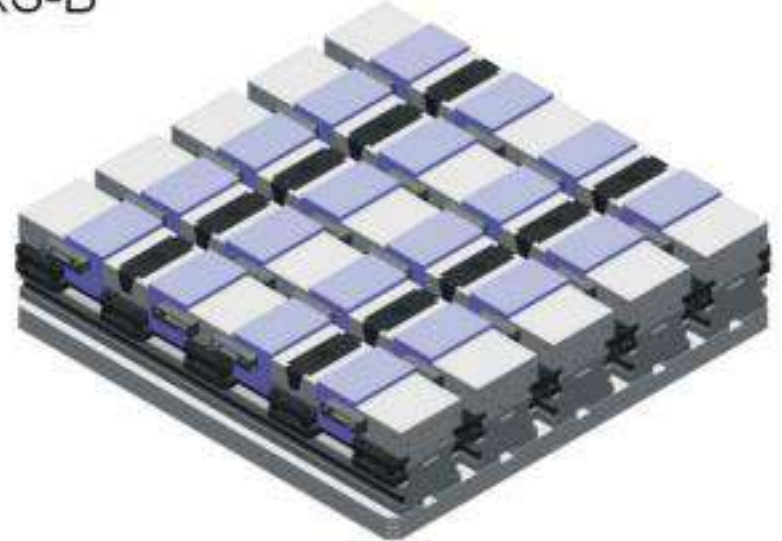

等距夾持 Equidistant clamping

MKS-A



不等距夾持 Not equidistant clamping

MKS-B

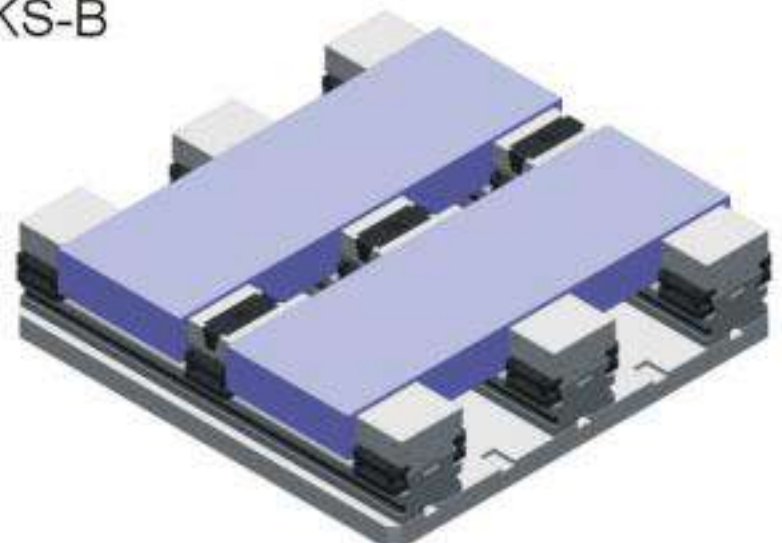

不等距夾持 Not equidistant clamping

MKS-A



搭配V型鉗口 with V clamp.

MKS-B

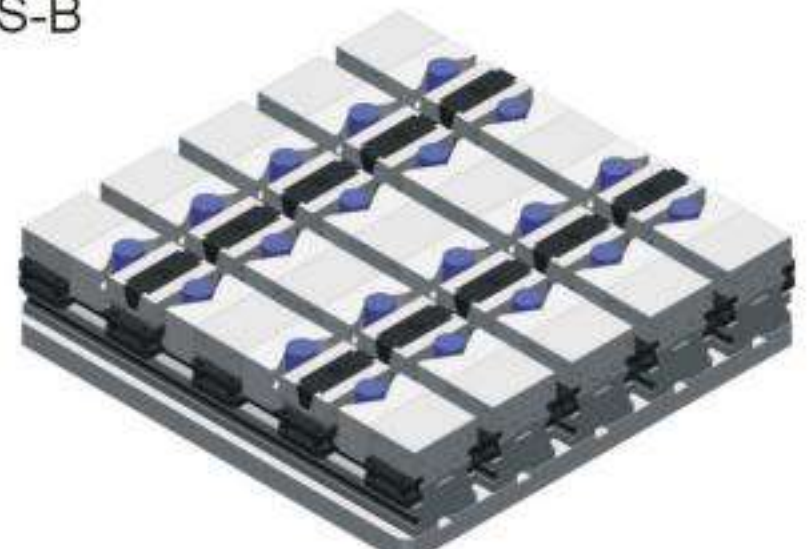

搭配V型鉗口 with V clamp.

# MKS-A / MKS-B

## 模組化並列式虎鉗應用實例

### Modular Clamping System Applications

MKS-A(單向平行夾持)  
(One side lockdown)

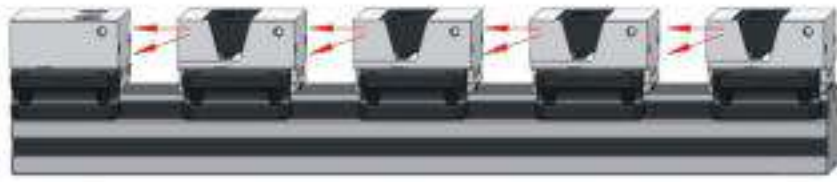

MKS-B(雙向平行夾持)  
(Dual sides lockdown)



(MKS型亦適用於卧式機床)  
on horizontal machining center applications:

詳細請參閱 Refer to Page

 C05、C07

MKS-A

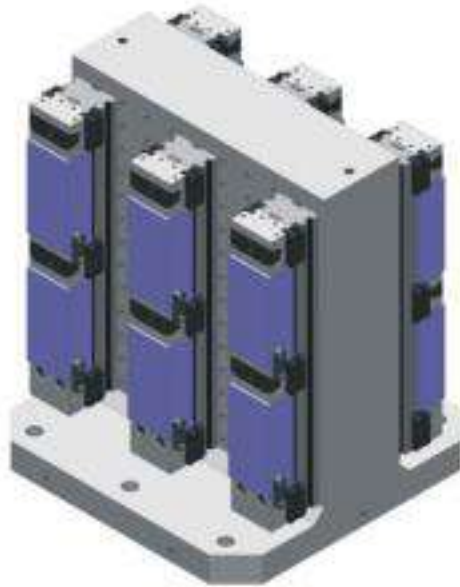

MKS-B



MKS-A

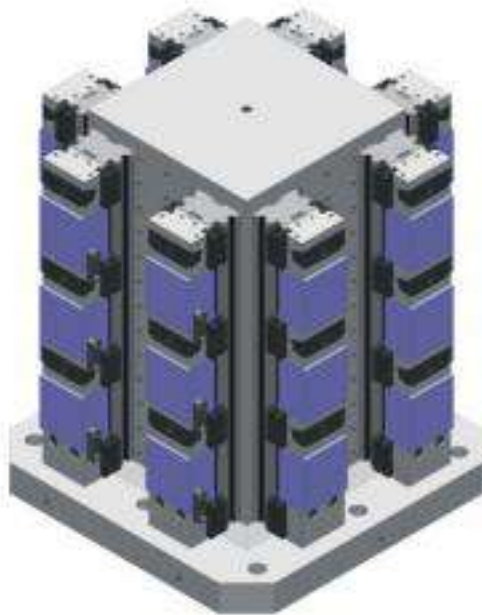

MKS-B



MKS-A

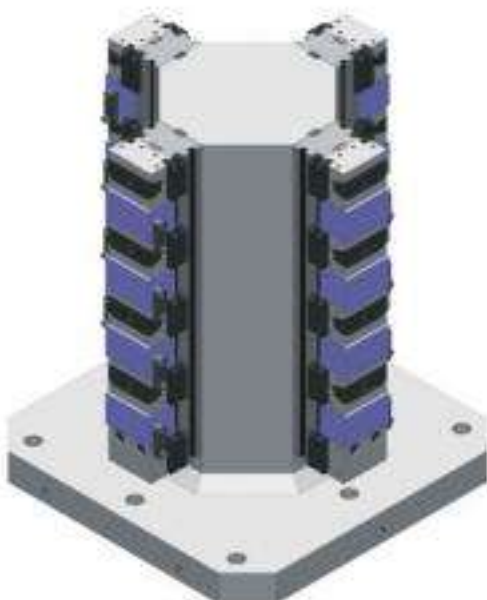

MKS-B

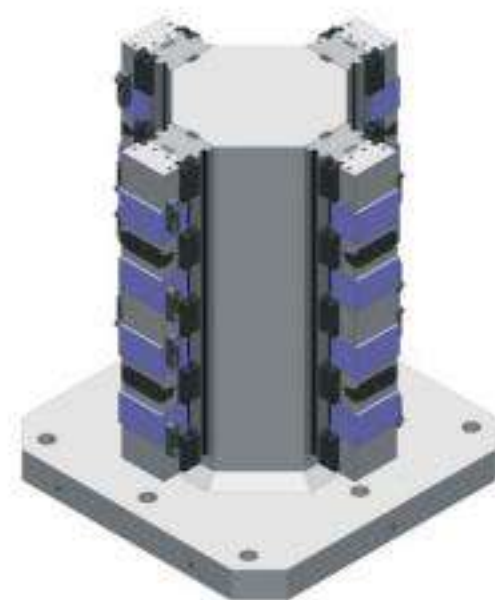

# MKS-A / MKS-B

## 模組化並列式虎鉗 Modular Clamping System

### MKS-A 單向平行夾持系列 One side lockdown

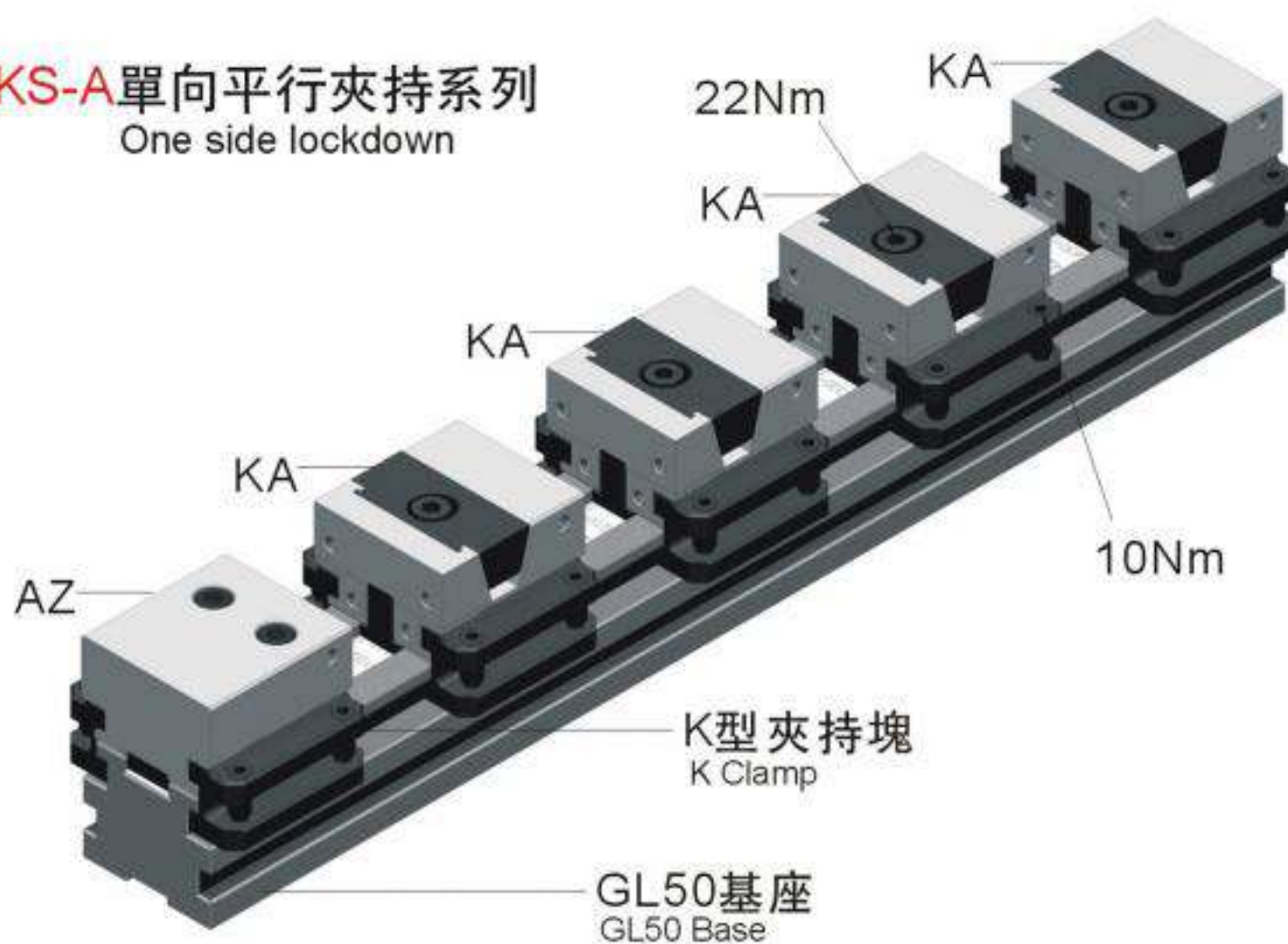

### MKS-B 雙向平行夾持系列 Dual side lockdown

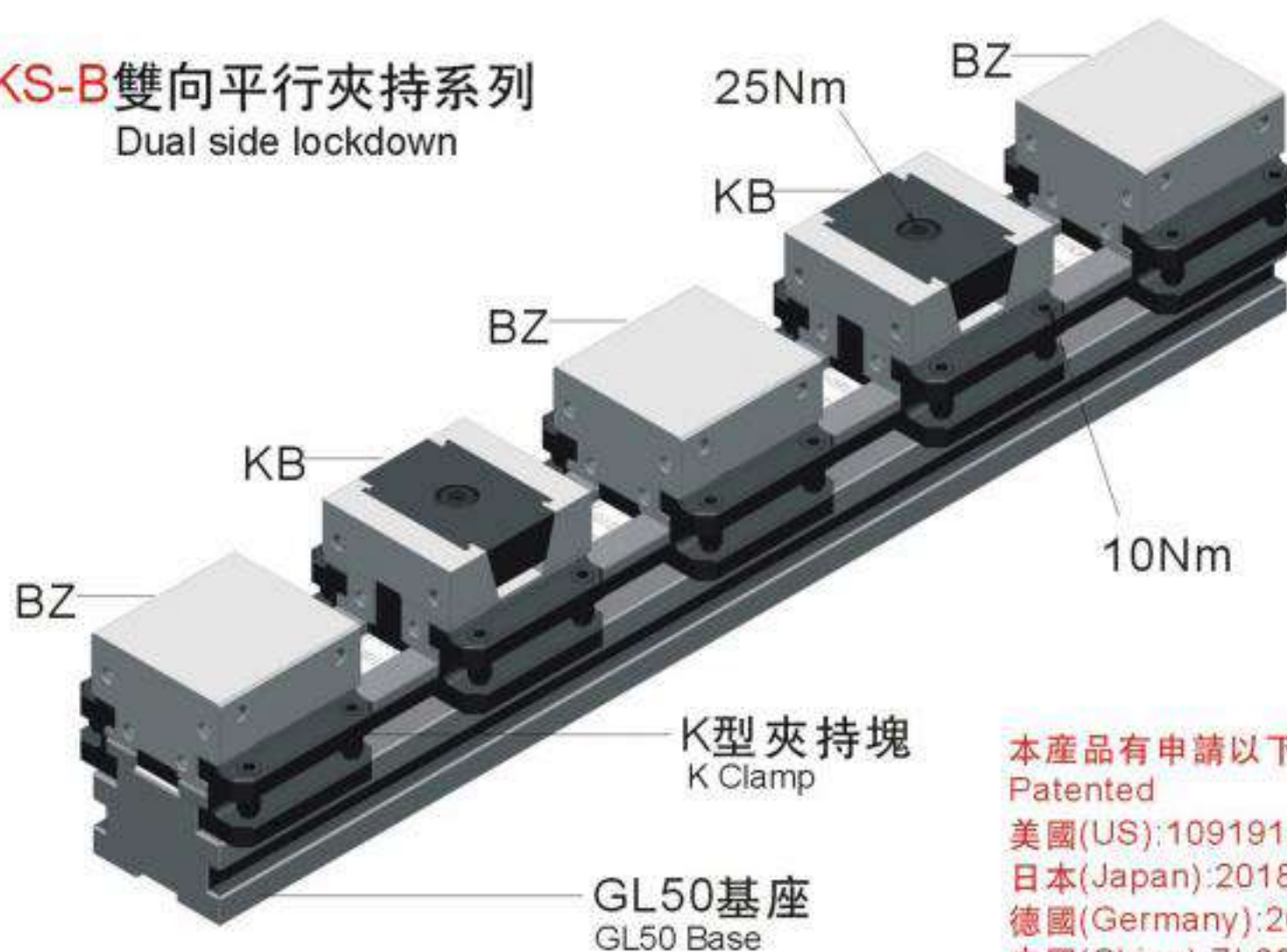

本產品有申請以下專利：  
Patented  
美國(US): 10919128  
日本(Japan): 2018-004513  
德國(Germany): 202018106562  
中國(China): ZL201821863903.2  
PAT: M572813

# MKS-A / MKS-B

## 分解示意圖 Part diagram

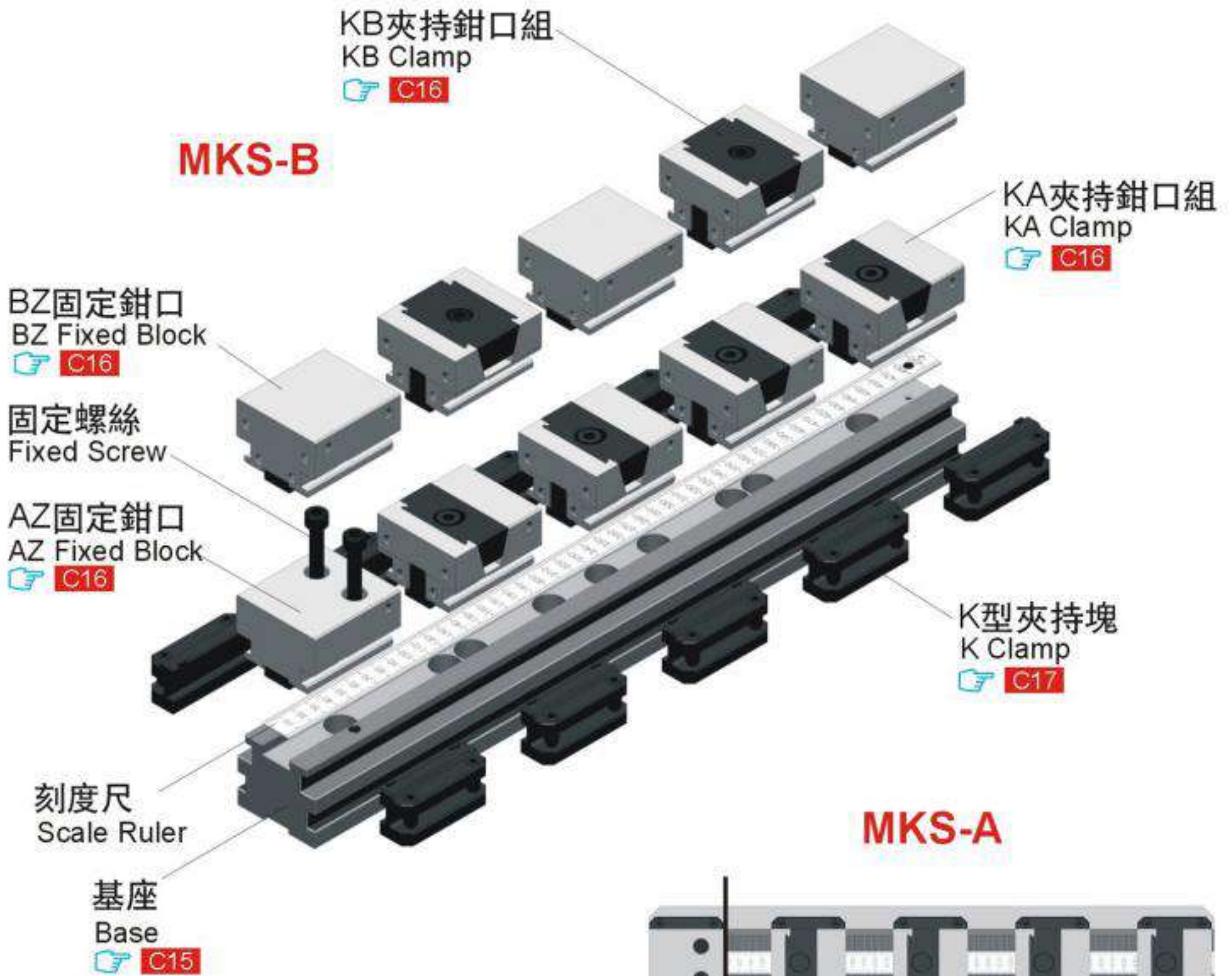

### 基本使用 Setting up

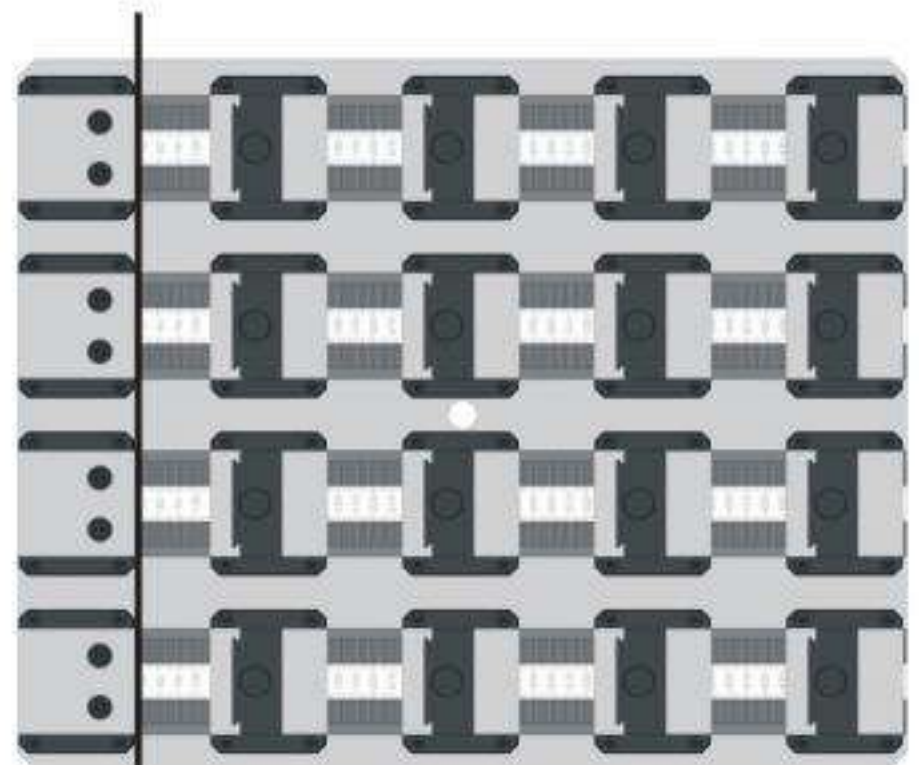

固定座鉗口於同一平面上  
Alignment parallel setup.



基座垂直於機台  
Alignment with perpendicularity setup.

# MKS-A 模組化並列式虎鉗 Modular Clamping System

MKS-A單向平行夾持系列 One side lockdown

MKS-A=GL50+AZ+KAx4

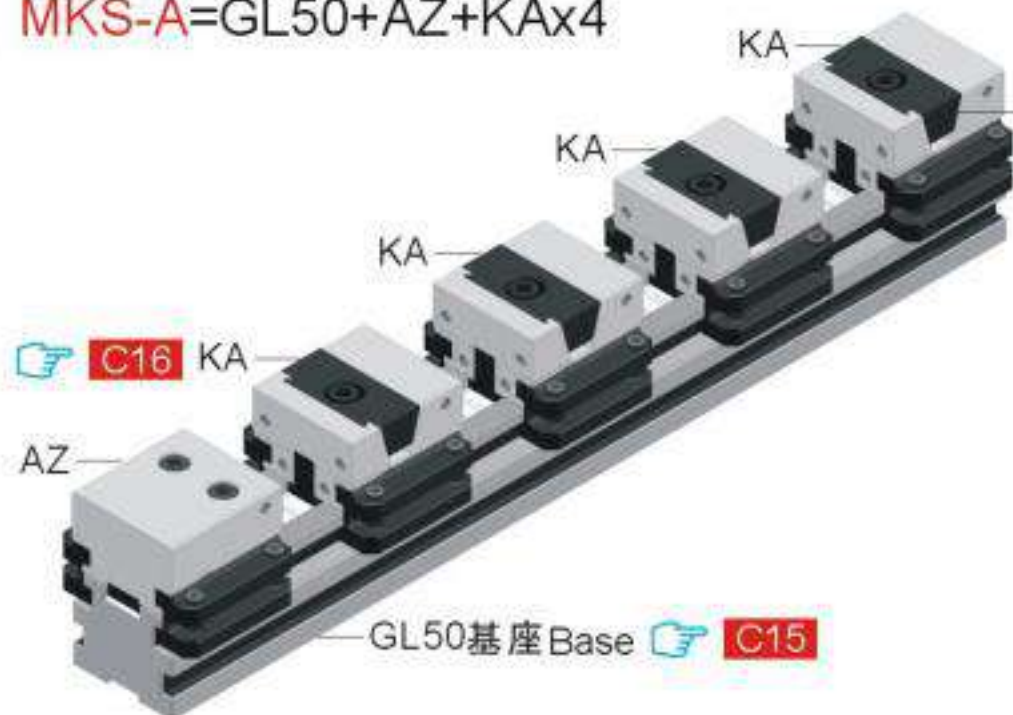

Tool steel **M** 工具鋼

**H** HRC48°~50°

**F** 2000kgf

## 特點Features:

- ▶ 推動塊做QPQ處理,耐用度高。
- ▶ 夾持鉗口組,拆裝簡單,位移方便,容易清潔。
- ▶ 夾持工件滿載時,上浮量以及垂直度精度保持在0.01/100mm內。工件夾持未滿載時上浮0.02mm。
- ▶ 多台並列運用於機床上夾持工作,可做到量加工產出。
- ▶ With (QPQ) Process on clamping block increasing wear-resistance.
- ▶ Easy operation increasing efficiency.
- ▶ When workpiece is fully clamped and contact with clamping block surface, accuracy remain within 0.01/100mm, not fully float up 0.02mm.
- ▶ Mass production by applying multiple parallel-use.

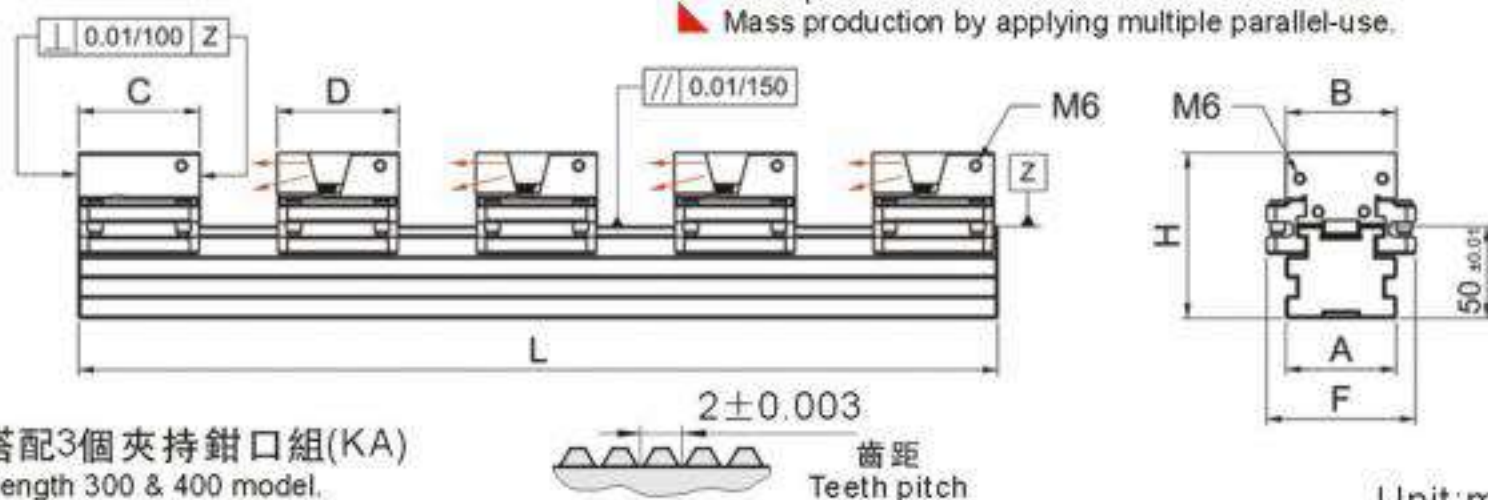

※ 基座300和400長,只搭配3個夾持鉗口組(KA)

※: Only KA x 3pcs included in length 300 & 400 model.

Unit:mm

訂購編號 Order No.	型號 Model	L	A	B	C	D	F	H	N.W.(kg)
64000A-300	MKS-A-048300	300※							10.87
64000A-400	MKS-A-048400	400※							12.77
64000A-500	MKS-A-048500	500	60	48	66	66	81	90	16.07
64000A-600	MKS-A-048600	600							17.86
64000A-700	MKS-A-048700	700							19.81
64002A-300	MKS-A-060300	300※							11.48
64002A-400	MKS-A-060400	400※							13.37
64002A-500	MKS-A-060500	500	60	60	66	66	81	90	16.83
64002A-600	MKS-A-060600	600							18.62
64002A-700	MKS-A-060700	700							20.57
64004A-400	MKS-A-080400	400※							19.33
64004A-500	MKS-A-080500	500							24.33
64004A-600	MKS-A-080600	600	80	80	66	72	99	95	26.97
64004A-700	MKS-A-080700	700							29.56
64004A-800	MKS-A-080800	800							32.19
64006A-400	MKS-A-100400	400※							24.51
64006A-500	MKS-A-100500	500							30.80
64006A-600	MKS-A-100600	600	100	100	66	72	119	95	34.23
64006A-700	MKS-A-100700	700							37.61
64006A-800	MKS-A-100800	800							41.05



# MKS-A

## 夾持示意圖 Clamping Range Demo

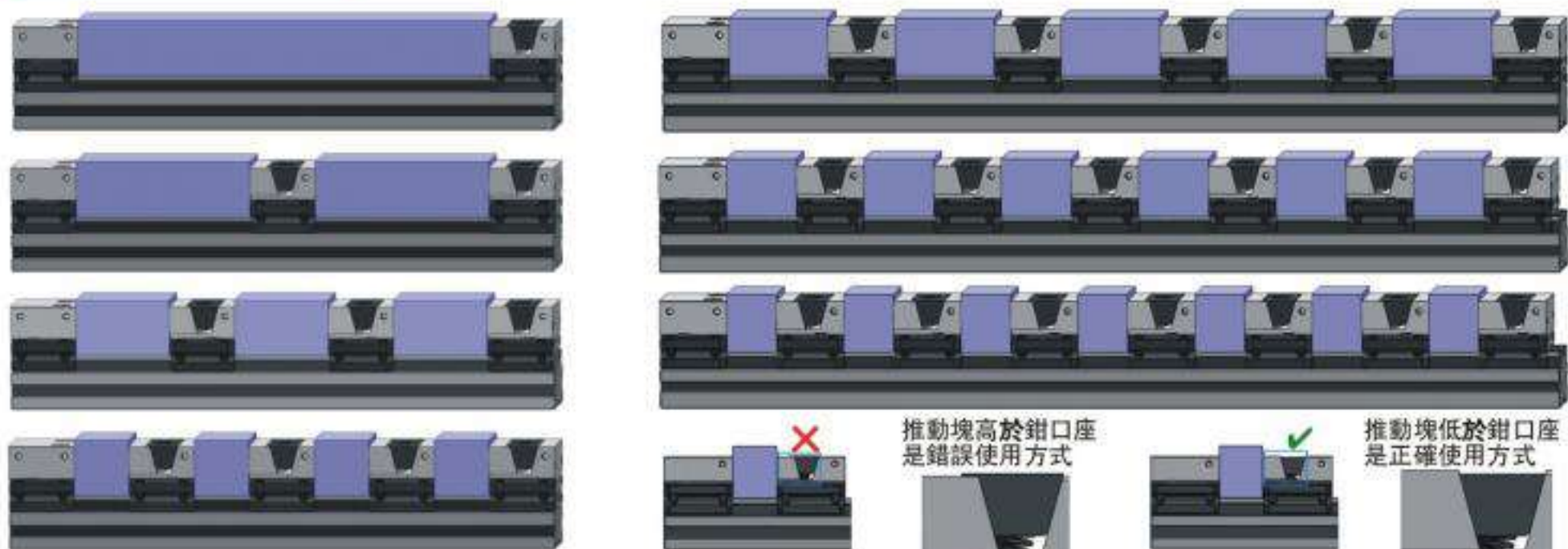

推動塊高於鉗口座  
是錯誤使用方式

推動塊低於鉗口座  
是正確使用方式

Unit:mm

型號 Model	一個工件 1 workpiece	二個工件 2 workpiece	三個工件 3 workpiece	四個工件 4 workpiece
	MKS-A-048300	168	50	12
MKS-A-048400	268	100	44	16
MKS-A-048500	368	150	78	42
MKS-A-048600	468	200	112	66
MKS-A-048700	568	250	144	92
MKS-A-060300	168	50	12	--
MKS-A-060400	268	100	44	16
MKS-A-060500	368	150	78	42
MKS-A-060600	468	200	112	66
MKS-A-060700	568	250	144	92
MKS-A-080400	268	100	44	16
MKS-A-080500	368	150	78	42
MKS-A-080600	468	200	112	66
MKS-A-080700	568	250	144	92
MKS-A-080800	668	300	178	116
MKS-A-100400	268	100	44	16
MKS-A-100500	368	150	78	42
MKS-A-100600	468	200	112	66
MKS-A-100700	568	250	144	92
MKS-A-100800	668	300	178	116
型號 Model	五個工件 5 workpiece	六個工件 6 workpiece	七個工件 7 workpiece	八個工件 8 workpiece
	MKS-A-048300	--	--	--
MKS-A-048400	--	--	--	--
MKS-A-048500	20	6	--	--
MKS-A-048600	40	22	10	--
MKS-A-048700	60	38	24	12
MKS-A-060300	--	--	--	--
MKS-A-060400	--	--	--	--
MKS-A-060500	20	6	--	--
MKS-A-060600	40	22	10	--
MKS-A-060700	60	38	24	12
MKS-A-080400	--	--	--	--
MKS-A-080500	20	6	--	--
MKS-A-080600	40	22	10	--
MKS-A-080700	60	38	24	12
MKS-A-080800	80	56	38	24
MKS-A-100400	--	--	--	--
MKS-A-100500	20	6	--	--
MKS-A-100600	40	22	10	--
MKS-A-100700	60	38	24	12
MKS-A-100800	80	56	38	24

# MKS-B 模組化並列式虎鉗 Modular Clamping System

MKS-B雙向平行夾持系列 Dual side lockdown

MKS-B=GL50+BZx3+KBx2

Tool steel **M** 工具鋼

**H** HRC48°~50°

**F** 2000kgf

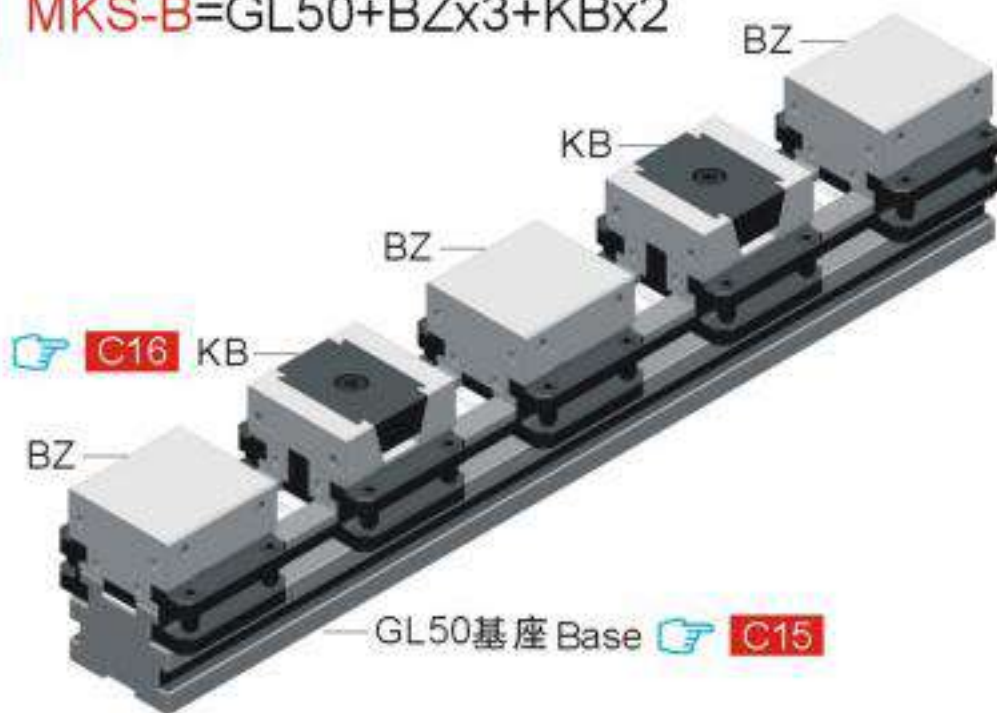

## 特點Features:

- ▶ 推動塊做QPQ處理,耐用度高。
- ▶ 夾持鉗口組,拆裝簡單,位移方便,容易清潔。
- ▶ 夾持工件滿載時,上浮量以及垂直度精度保持在0.01/100mm內。工件夾持未滿載時上浮0.02mm。
- ▶ 多台並列運用於機床上夾持工作,可做到量加工產出。
- ▶ With (QPQ) Process on clamping block increasing wear-resistance.
- ▶ Easy operation increasing efficiency.
- ▶ When workpiece is fully clamped and contact with clamping block surface, accuracy remain within 0.01/100mm, not fully float up 0.02mm.
- ▶ Mass production by applying multiple parallel-use.

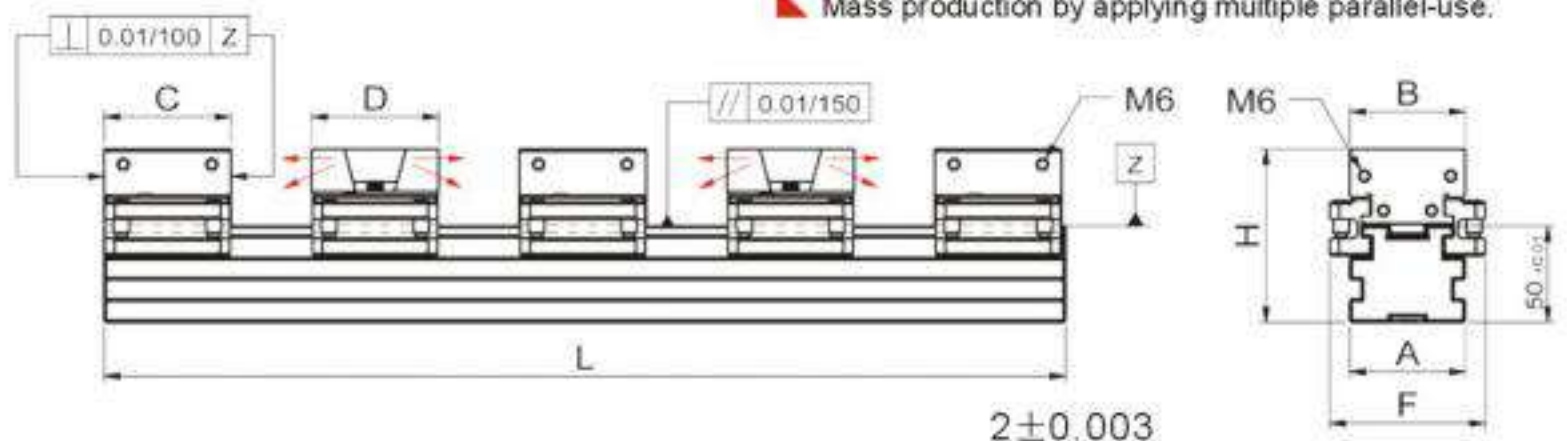

※ 基座300長, 只搭配1個夾持鉗口組(KB)以及2個固定鉗口組(BZ)

※: Only KB x 1pc and BZ x 2pcs included in length 300 MKS-B model.



Unit:mm

訂購編號 Order No.	型號 Model	L	A	B	C	D	F	H	N.W.(kg)
64008B-300	MKS-B-048300	300※	60	48	50	50	81	90	8.59
64008B-400	MKS-B-048400	400							13.58
64008B-500	MKS-B-048500	500							14.50
64008B-600	MKS-B-048600	600							16.29
64008B-700	MKS-B-048700	700							18.25
64010B-300	MKS-B-060300	300※	60	60	50	50	81	90	8.94
64010B-400	MKS-B-060400	400							14.28
64010B-500	MKS-B-060500	500							15.08
64010B-600	MKS-B-060600	600							16.87
64010B-700	MKS-B-060700	700							18.83
64012B-400	MKS-B-080400	400	80	80	60	60	99	95	21.66
64012B-500	MKS-B-080500	500							22.52
64012B-600	MKS-B-080600	600							25.16
64012B-700	MKS-B-080700	700							27.74
64012B-800	MKS-B-080800	800							30.39
64014B-400	MKS-B-100400	400	100	100	60	60	119	95	27.40
64014B-500	MKS-B-100500	500							28.62
64014B-600	MKS-B-100600	600							32.05
64014B-700	MKS-B-100700	700							35.43
64014B-800	MKS-B-100800	800							38.87

# MKS-B

## 夾持示意圖 Clamping Range Demo

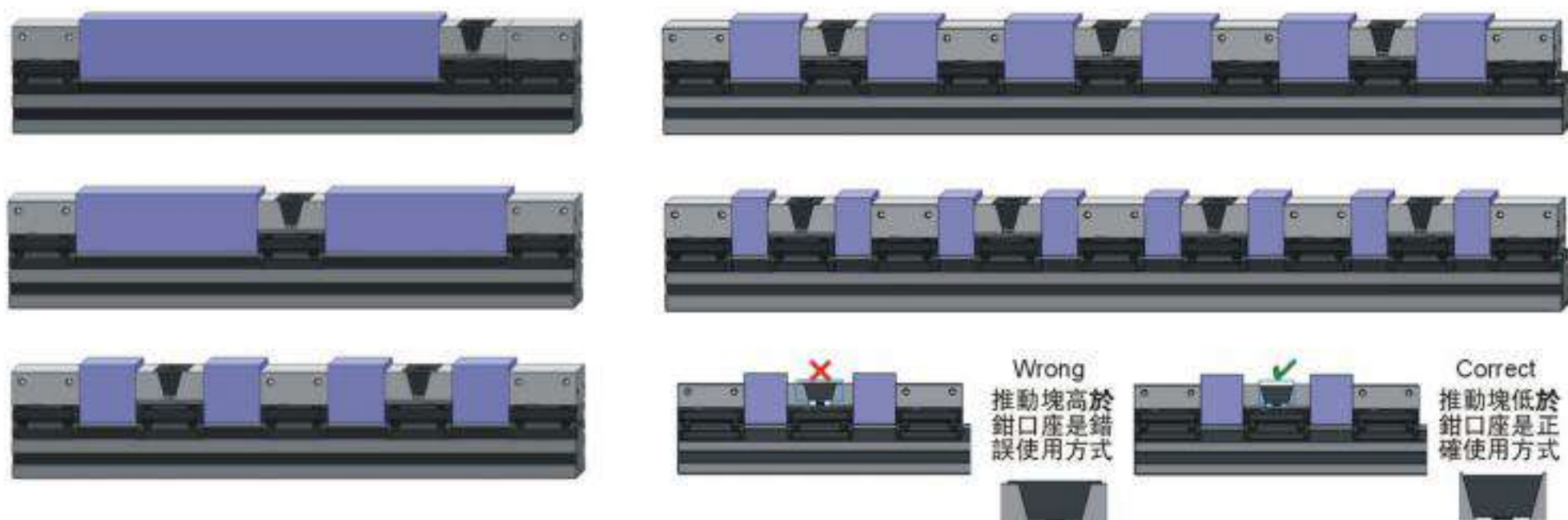

Wrong  
推動塊高於  
鉗口座是錯  
誤使用方式

Correct  
推動塊低於  
鉗口座是正  
確使用方式

Unit:mm

型號 Model	一個工件 1 workpiece	二個工件 2 workpiece	三個工件 3 workpiece	四個工件 4 workpiece
MKS-B-048300	150	75	--	--
MKS-B-048400	250	125	--	37
MKS-B-048500	350	175	--	62
MKS-B-048600	450	225	--	67
MKS-B-048700	550	275	--	92
MKS-B-060300	150	75	--	--
MKS-B-060400	250	125	--	37
MKS-B-060500	350	175	--	62
MKS-B-060600	450	225	--	67
MKS-B-060700	550	275	--	92
MKS-B-080400	220	110	--	17
MKS-B-080500	320	160	--	42
MKS-B-080600	420	210	--	67
MKS-B-080700	520	260	--	92
MKS-B-080800	620	310	--	117
MKS-B-100400	220	110	--	17
MKS-B-100500	320	160	--	42
MKS-B-100600	420	210	--	67
MKS-B-100700	520	260	--	92
MKS-B-100800	620	310	--	117
型號 Model	五個工件 5 workpiece	六個工件 6 workpiece	七個工件 7 workpiece	八個工件 8 workpiece
MKS-B-048300	--	--	--	--
MKS-B-048400	--	--	--	--
MKS-B-048500	--	24	--	12
MKS-B-048600	--	40	--	24
MKS-B-048700	--	58	--	36
MKS-B-060300	--	--	--	--
MKS-B-060400	--	--	--	--
MKS-B-060500	--	24	--	12
MKS-B-060600	--	40	--	24
MKS-B-060700	--	58	--	36
MKS-B-080400	--	--	--	--
MKS-B-080500	--	12	--	--
MKS-B-080600	--	30	--	6
MKS-B-080700	--	46	--	20
MKS-B-080800	--	62	--	32
MKS-B-100400	--	--	--	--
MKS-B-100500	--	12	--	--
MKS-B-100600	--	30	--	6
MKS-B-100700	--	46	--	20
MKS-B-100800	--	62	--	32

# MCS-C

## 模組化並列式虎鉗

### Modular Clamping System

MCS-C單口下拉夾持系列Single lockdown series

MCS-C=GL50+CZ+CC+CE

Tool steel **M** 工具鋼

**H** HRC48°~50°

**F** 2000kgf

#### 特點Features:

- ▲ 夾持鉗口組, 拆裝簡單, 位移方便, 容易清潔。
- ▲ 因夾持鉗口設計下拉推動, 夾持工件滿載時, 上浮量可維持5μ以內。
- ▲ 多台並列運用於機床上夾持工作, 可做到量加工產出。
- ▲ Operation increasing efficiency.
- ▲ Lockdown mechanism, when workpiece is fully clamped keeping lifting within in 0.005mm.
- ▲ Mass production by applying multiple parallel-use.

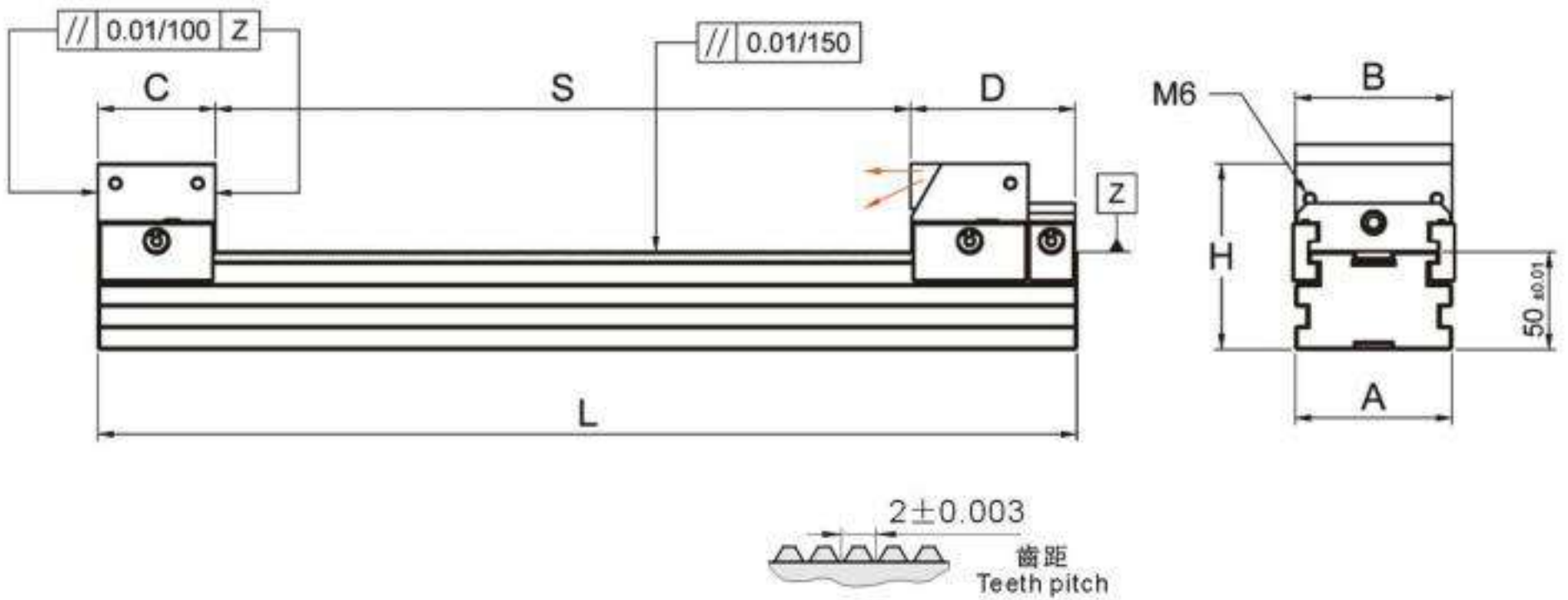
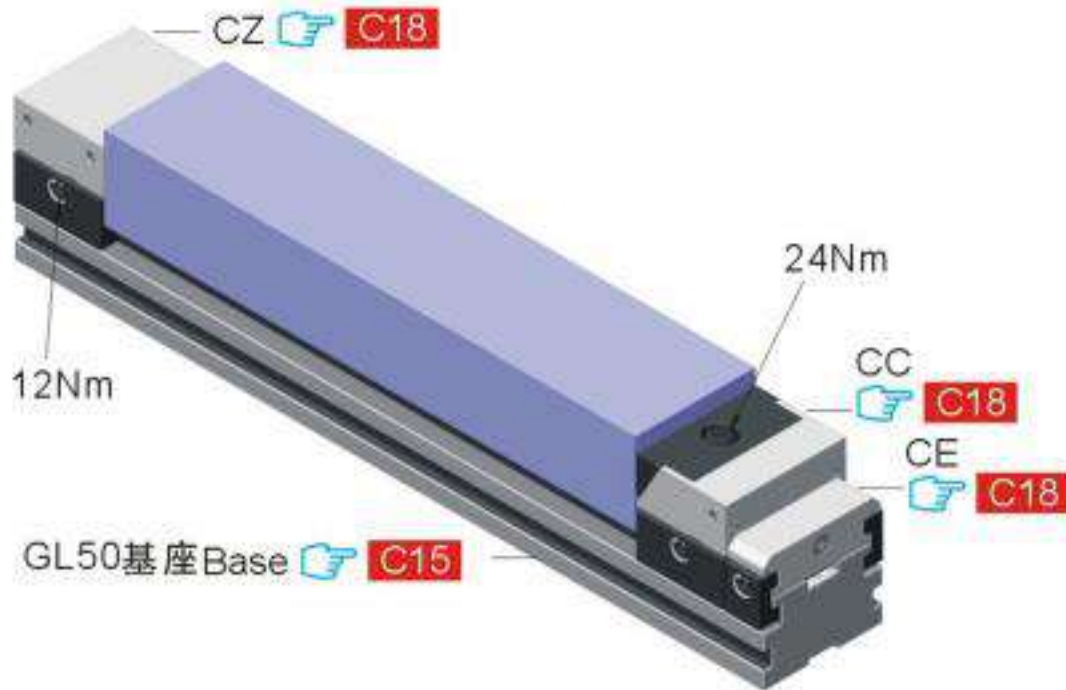

Unit:mm

訂購編號 Order No.	型號 Model	L	A	B	C	D	H	S	N.W.(kg)
64016C-400	MCS-C-080400	400	80	80	60	84	95	0~255	14.10
64016C-500	MCS-C-080500	500						0~355	16.83
64016C-600	MCS-C-080600	600						0~455	19.43
64016C-700	MCS-C-080700	700						0~555	21.96
64016C-800	MCS-C-080800	800						0~655	24.56
64018C-400	MCS-C-100400	400	100	100	60	84	95	0~255	18.23
64018C-500	MCS-C-100500	500						0~355	21.75
64018C-600	MCS-C-100600	600						0~455	23.11
64018C-700	MCS-C-100700	700						0~555	25.14
64018C-800	MCS-C-100800	800						0~655	26.48

# MCS-D 模組化並列式虎鉗

## Modular Clamping System

MCS-D雙口下拉夾持系列 Double lockdown series

MCS-D=GL50+CZ+CC+CE

Tool steel **M** 工具鋼

**H** HRC48°~50°

**F** 2000kgf

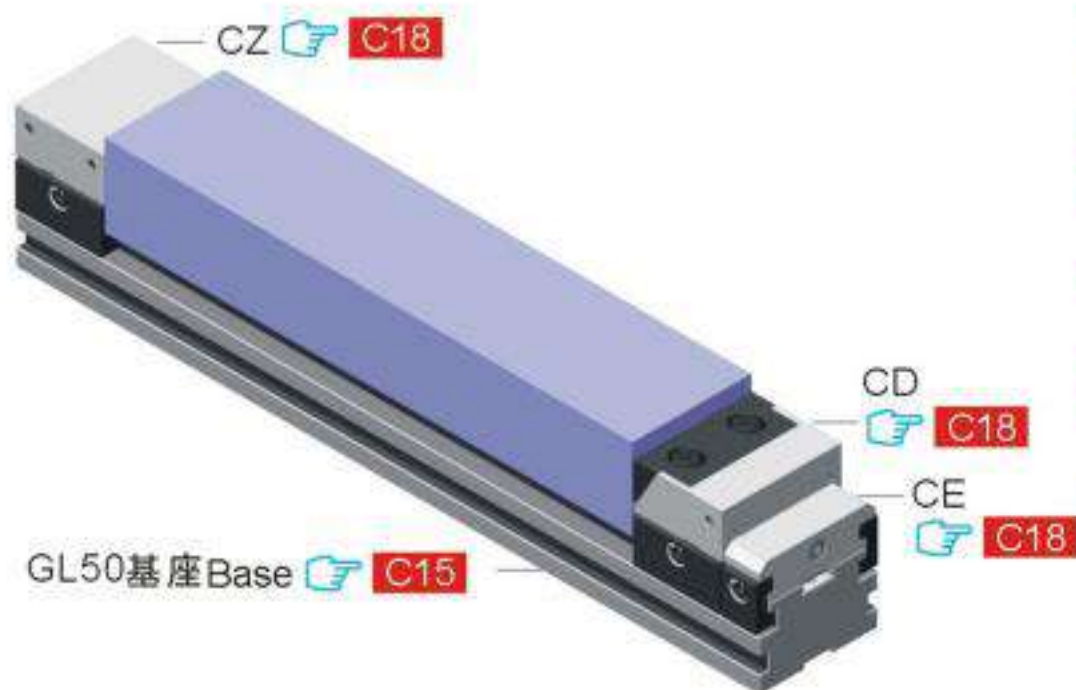

### 特點Features:

- ▲ 夾持鉗口組, 拆裝簡單, 位移方便, 容易清潔。
- ▲ 因夾持鉗口設計下拉推動, 夾持工件滿載時, 上浮量可維持5 $\mu$ 以內。
- ▲ 多台並列運用於機床上夾持工作, 可做到量加工產出。
- ▲ Operation increasing efficiency.
- ▲ Lockdown mechanism, when workpiece is fully clamped keeping lifting within in 0.005mm.
- ▲ Mass production by applying multiple parallel-use.

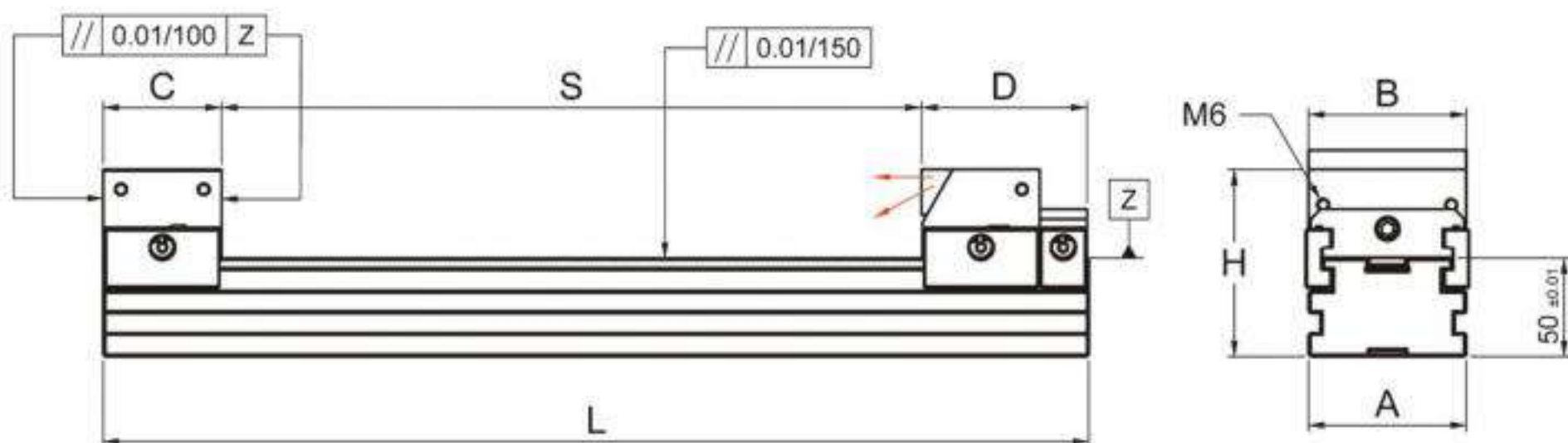

Unit:mm

訂購編號 Order No.	型號 Model	L	A	B	C	D	H	S	N.W.(kg)
64020D-400	MCS-D-080400	400	80	80	60	84	95	0~255	14.07
64020D-500	MCS-D-080500	500						0~355	16.80
64020D-600	MCS-D-080600	600						0~455	19.40
64020D-700	MCS-D-080700	700						0~555	21.93
64020D-800	MCS-D-080800	800						0~655	24.53
64022D-400	MCS-D-100400	400	100	100	60	84	95	0~255	18.20
64022D-500	MCS-D-100500	500						0~355	21.72
64022D-600	MCS-D-100600	600						0~455	23.08
64022D-700	MCS-D-100700	700						0~555	25.11
64022D-800	MCS-D-100800	800						0~655	26.45

**MKS**

# 並列式虎鉗轉接系列

## MKS Adaptor series

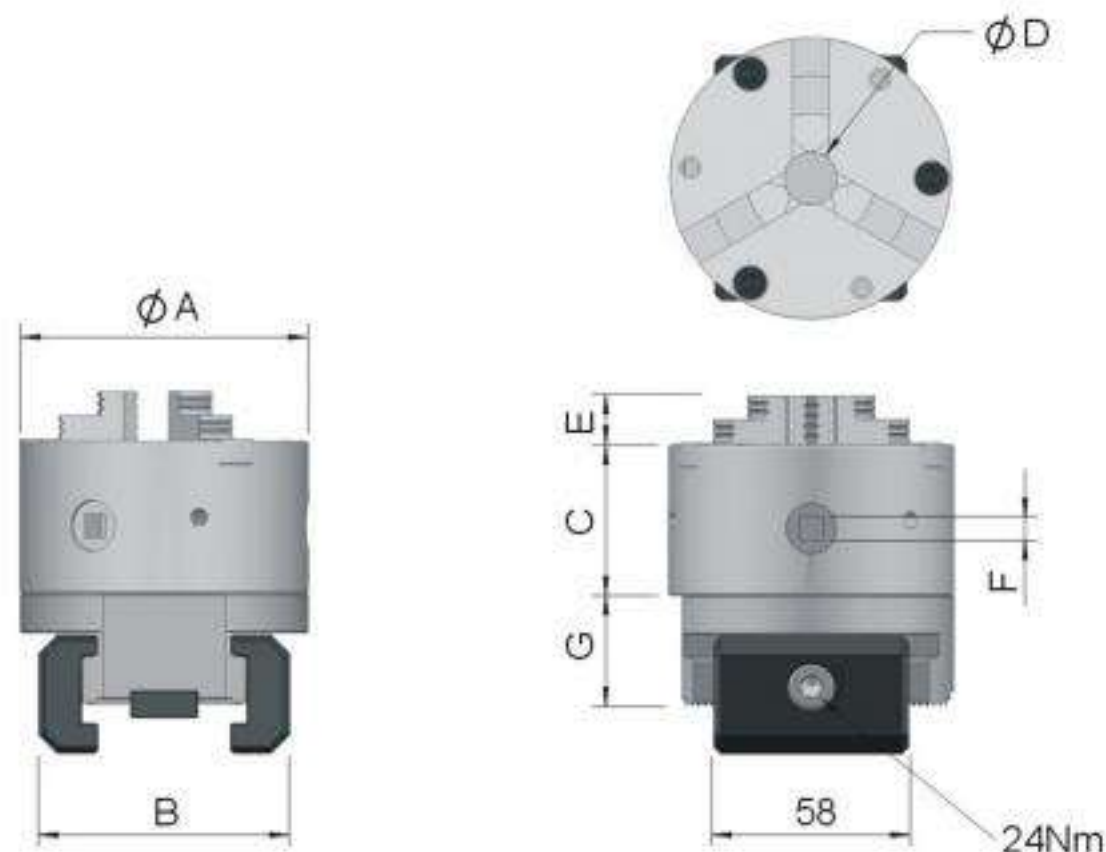

### 三爪夾頭連接座組

Jaw Chuck &amp; Adaptor for MKS

M 軸承鋼 SUJ2 H HRC45°~50°

Unit:mm

訂購編號 Order No.	型號 Model	A	B	C	D	E	F	G	N.W.(kg)
64024-060	CJ060	85	74	45	16	15	7	32.1	3.49
64024-080	CJ080	112	92	58	24	17	8	32.1	6.58
64024-100	CJ100	132	112	60	32	20	8	32.1	9.56

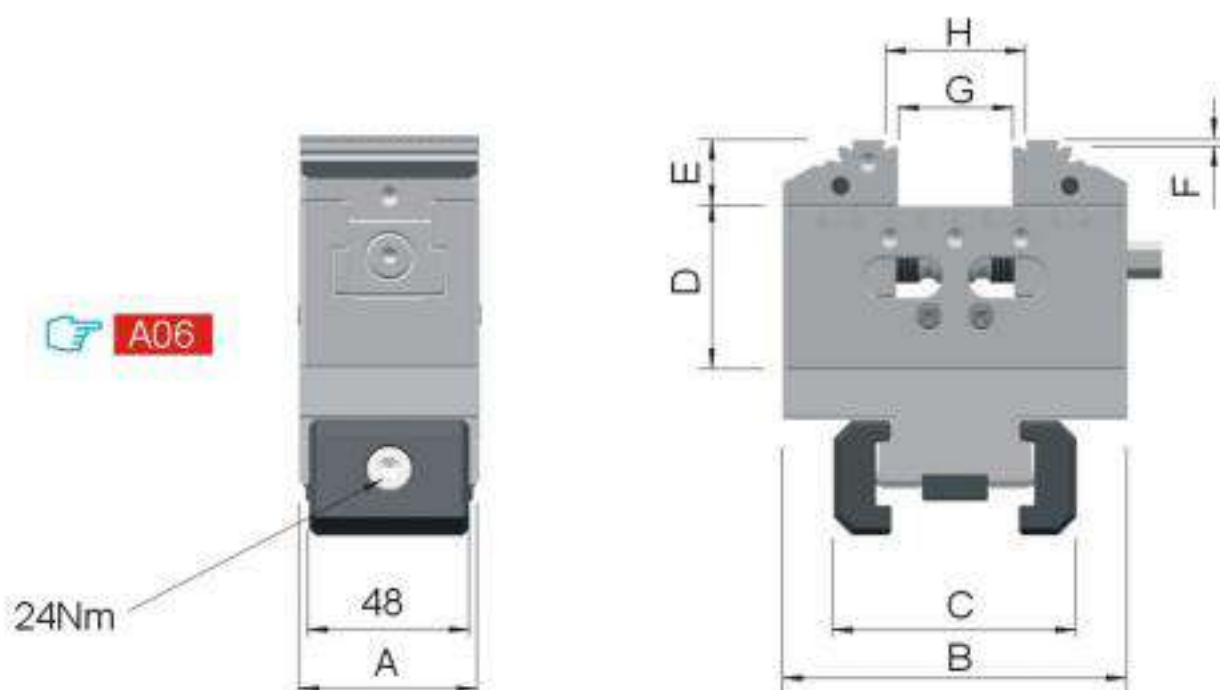

### 求心虎鉗連接座組

PQV204V Vise &amp; Adaptor for MKS

M 預硬鋼 P75

Unit:mm

訂購編號 Order No.	型號 Model	A	B	C	D	E	F	G	H	N.W.(kg)
64026-060	CP060	54	105	74	50	20	2	0~35	8~43	3.49

## 並列式虎鉗轉接座使用數量示意圖 MKS Adaptor Application

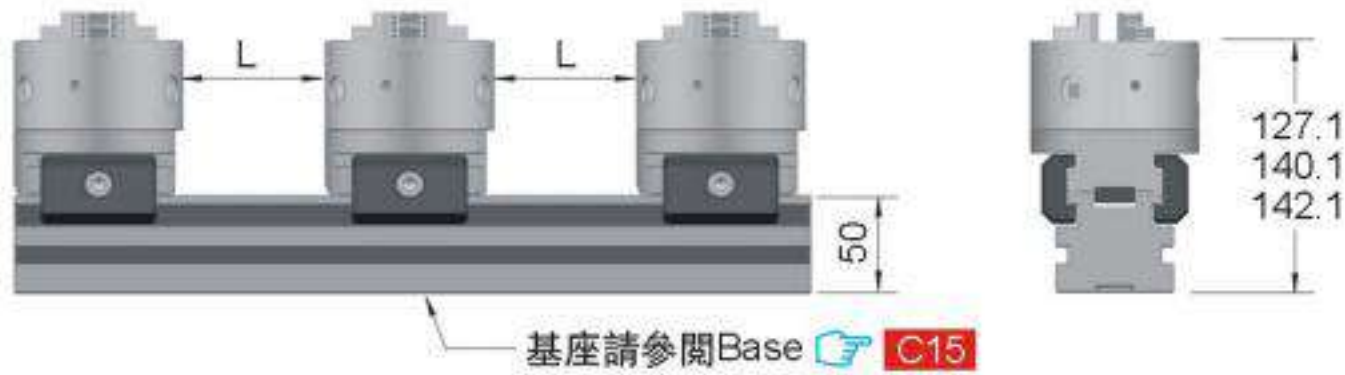

### 三爪夾頭並列使用數量與間距

Distance between qty of chuck applied.

Unit:mm

型號 Model	二個夾頭 (L) 2 chucks (L)	三個夾頭 (L) 3 chucks (L)	四個夾頭 (L) 4 chucks (L)	五個夾頭 (L) 5 chucks (L)	六個夾頭 (L) 6 chucks (L)
MKS-CJ-060300	129	21	--	--	--
MKS-CJ-060400	229	71	19	--	--
MKS-CJ-060500	329	121	53	--	--
MKS-CJ-060600	429	171	85	41	17
MKS-CJ-060700	529	221	119	65	37
MKS-CJ-080400	176	32	--	--	--
MKS-CJ-080500	276	82	16	--	--
MKS-CJ-080600	376	132	50	10	--
MKS-CJ-080700	476	182	84	34	--
MKS-CJ-080800	576	232	116	60	24
MKS-CJ-100400	136	2	--	--	--
MKS-CJ-100500	236	52	--	--	--
MKS-CJ-100600	336	102	24	--	--
MKS-CJ-100700	436	152	56	10	--
MKS-CJ-100800	536	202	90	34	--



### 求心虎鉗並列使用數量與間距

Distance between qty of self-centering vise (PQV204V) applied. ([A06](#))

Unit:mm

型號 Model	二個虎鉗 (L) 2 vises (L)	三個虎鉗 (L) 3 vises (L)	四個虎鉗 (L) 4 vises (L)	五個虎鉗 (L) 5 vises (L)	六個虎鉗 (L) 6 vises (L)	七個虎鉗 (L) 7 vises (L)	八個虎鉗 (L) 8 vises (L)	九個虎鉗 (L) 9 vises (L)
MKS-CP-060300	192	68	28	6	--	--	--	--
MKS-CP-060400	292	118	60	32	14	--	--	--
MKS-CP-060500	392	168	94	56	34	20	8	--
MKS-CP-060600	492	218	128	82	54	36	24	14
MKS-CP-060700	592	268	160	106	74	52	38	26

**MKS**

# GL50基座系列 (寬60mm)

GL50 Base series (60mm)

300mm

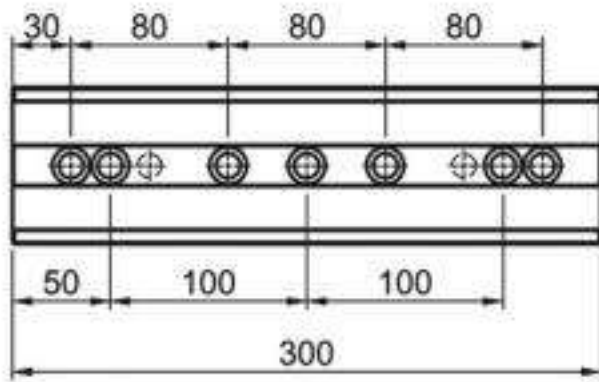

400mm

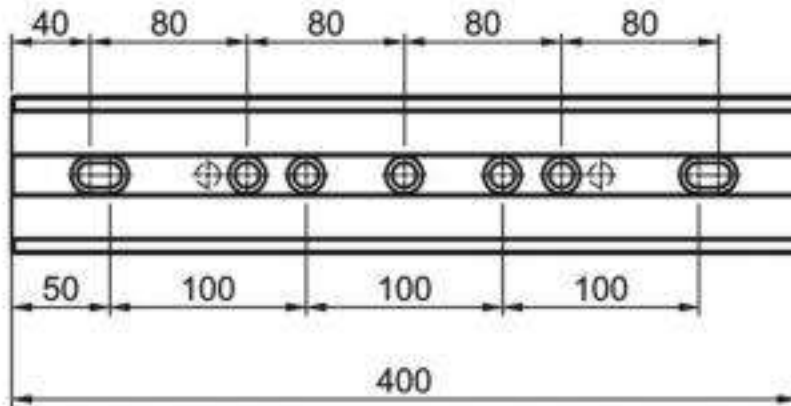

500mm

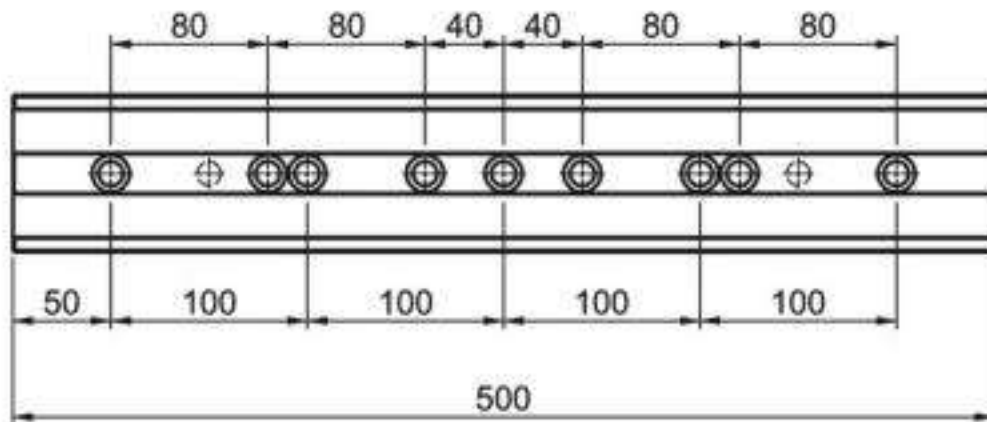

600mm

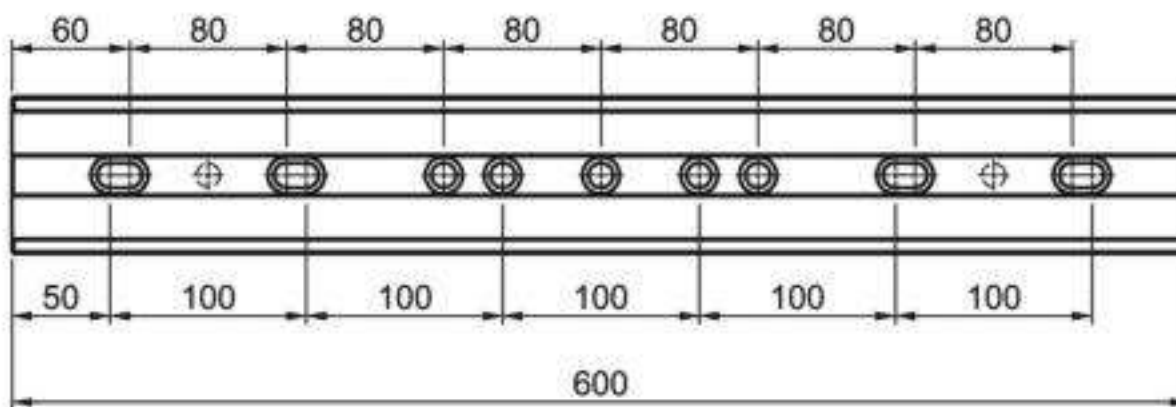

700mm

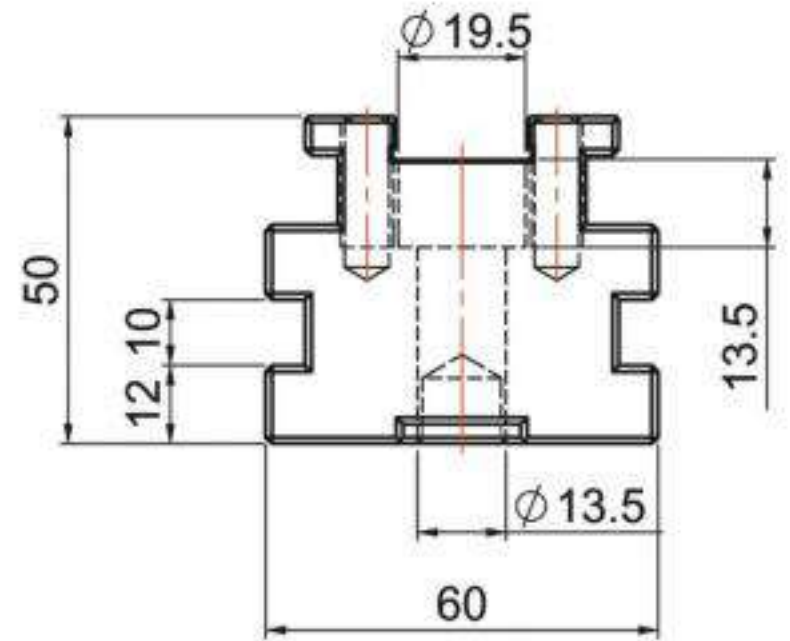
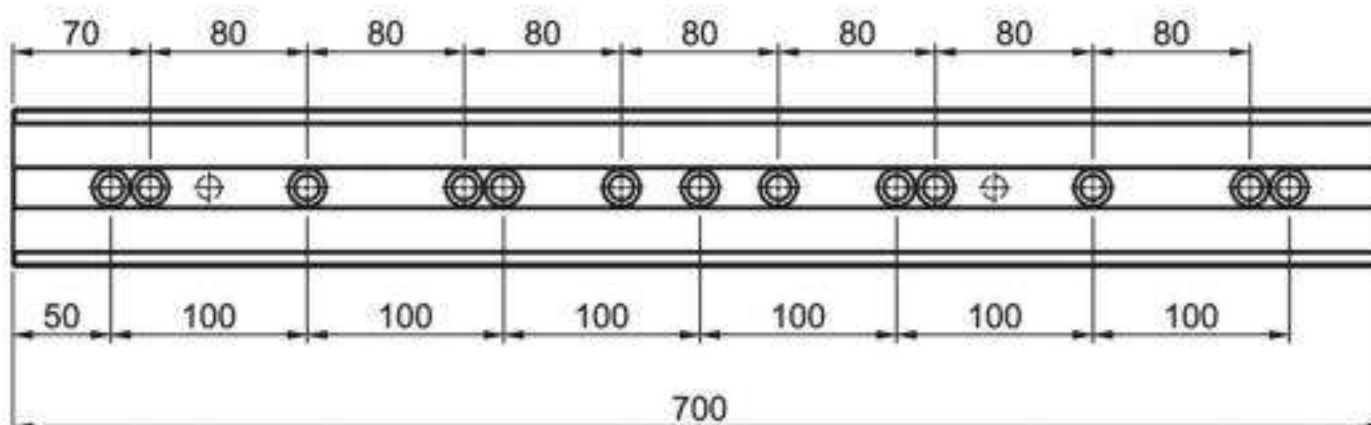

GL50-060  **C15**



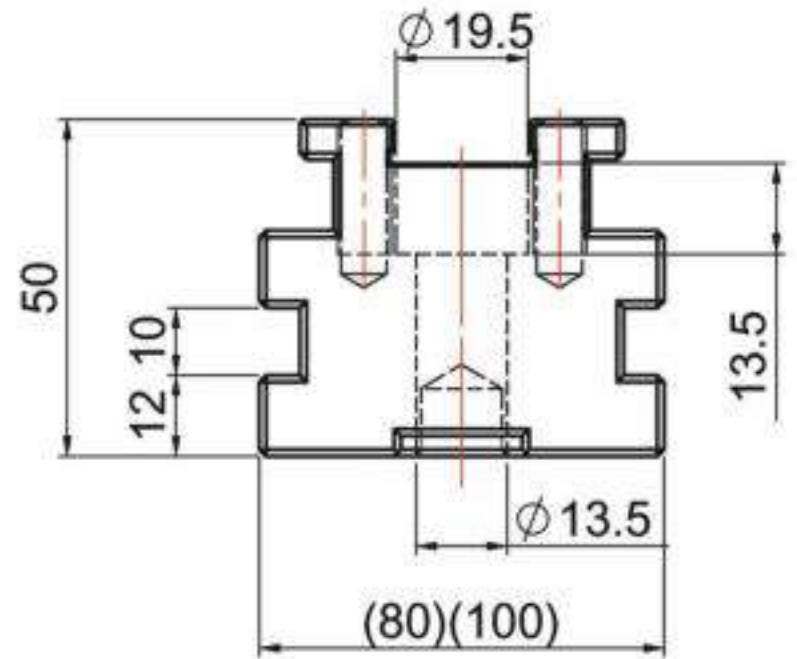
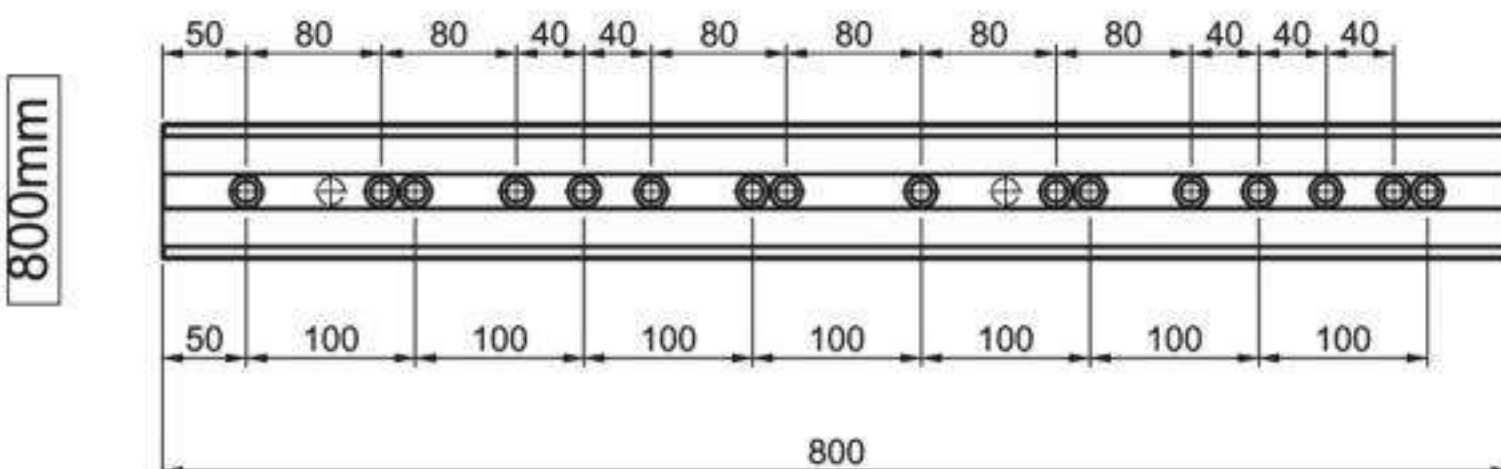
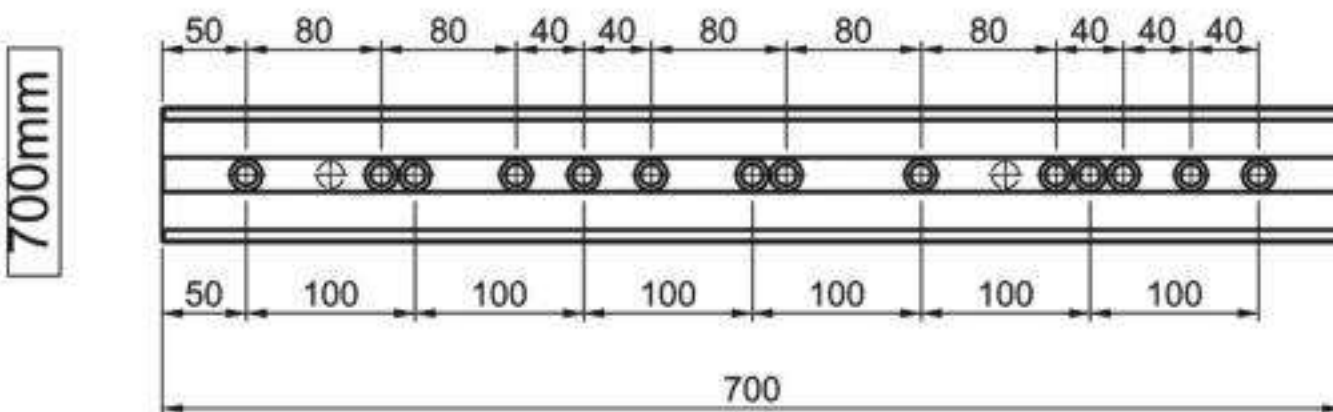
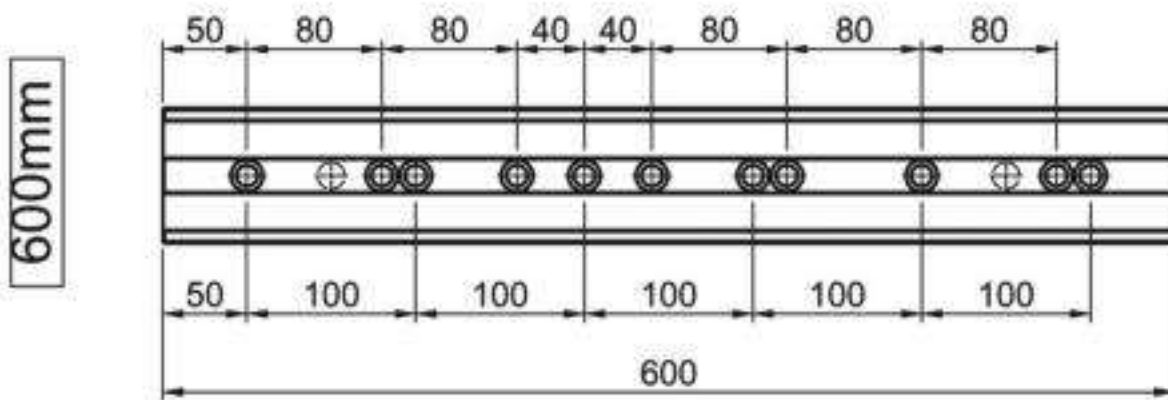
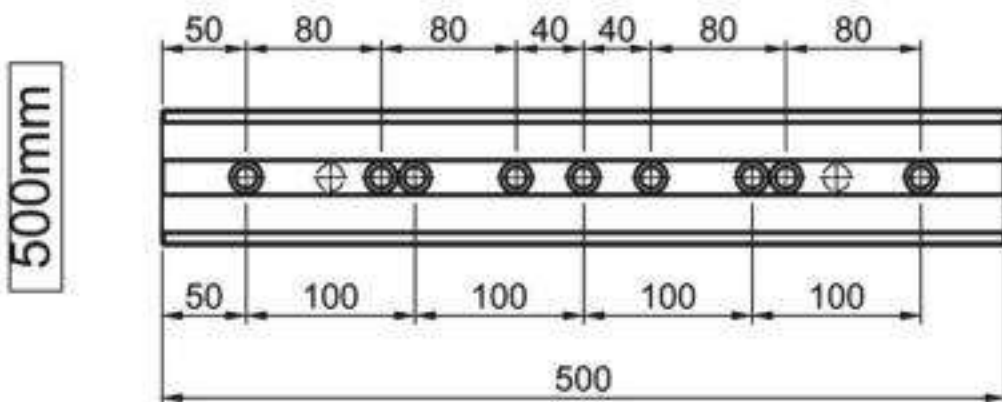
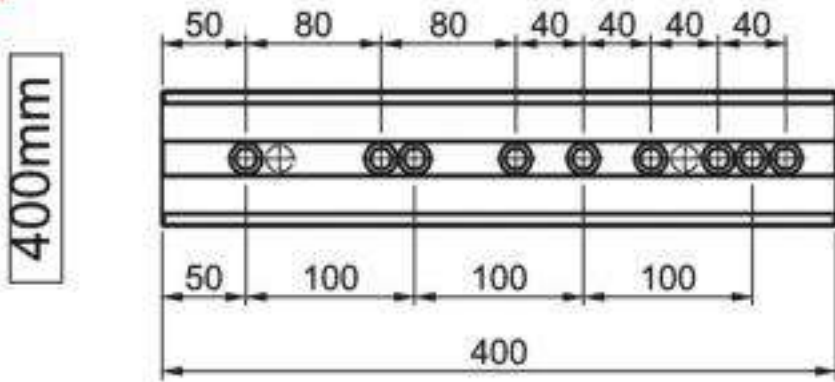

GL50-080 **C15**

GL50-100 **C15**

**MKS**

# GL50基座系列

## GL50 Base series

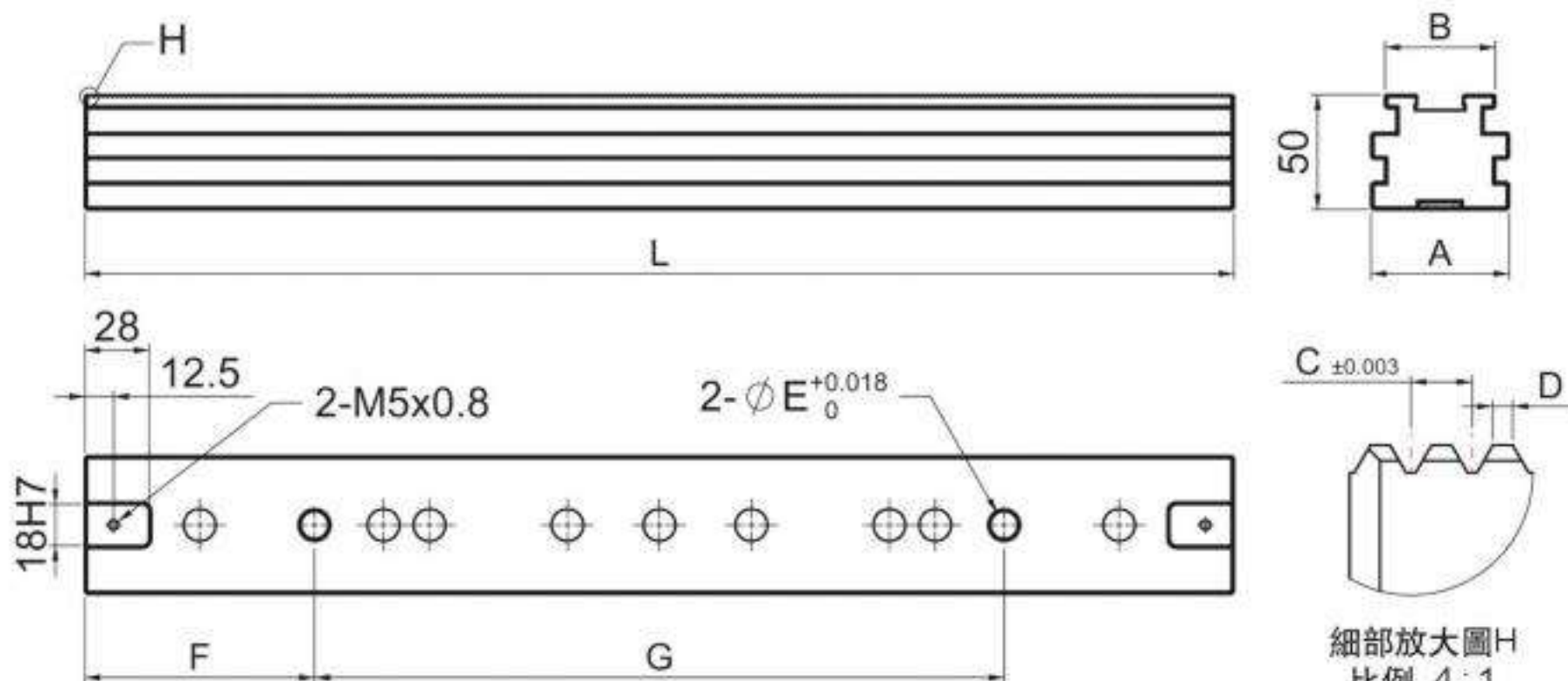

詳細尺寸規格請參閱 [C13~14](#)  
Specs refer to

細部放大圖H  
比例 4:1  
Detail H  
Scale 4:1

**M** SCM440 **H** HRC48°~50°

Unit:mm

訂購編號 Order No.	型號 Model	L	A	B	C	D	E	F	G	N.W.(kg)
64500G-300	GL50-060300	300	60	48	2	0.654	12	70	160	5.34
64500G-400	GL50-060400	400						200	7.19	
64500G-500	GL50-060500	500						300	9.13	
64500G-600	GL50-060600	600						400	10.87	
64500G-700	GL50-060700	700						400	12.77	
64502G-400	GL50-080400	400	80	66	2	0.654	16	70	240	10.21
64502G-500	GL50-080500	500						300	12.94	
64502G-600	GL50-080600	600						400	15.53	
64502G-700	GL50-080700	700						400	18.05	
64502G-800	GL50-080800	800						400	20.65	
64504G-400	GL50-100400	400	100	86	2	0.654	16	70	240	13.38
64504G-500	GL50-100500	500						300	16.91	
64504G-600	GL50-100600	600						400	20.29	
64504G-700	GL50-100700	700						400	23.66	
64504G-800	GL50-100800	800						400	27.00	

備注：整組含基座刻度板螺絲 Remark: graduation ruler and screws are included in set.

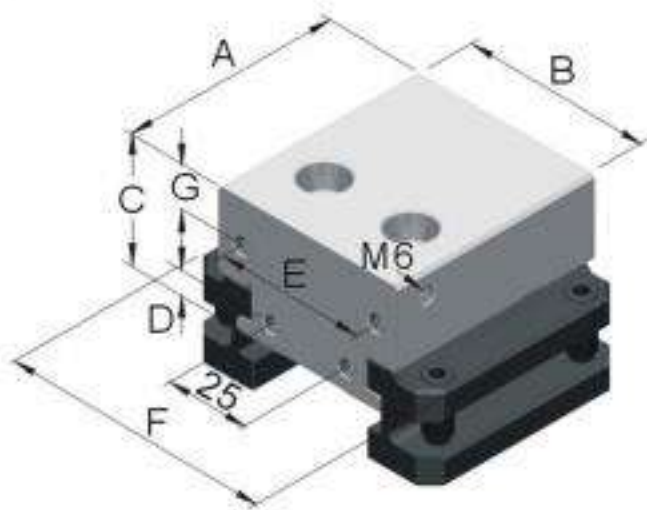

AZ固定鉗口組  
AZ Fixed block

**M** 工具鋼(Tool steel)  
**H** HRC48°~50°

Unit:mm

訂購編號 Order No.	型號 Model	A	B	C	D	E	F	G	N.W.(kg)
64028A-048	AZ048	66	48	40	8	35	81	14	1.35
64028A-060	AZ060	66	60	40	8	45	81	14	1.51
64028A-080	AZ080	66	80	45	10	65	99	18	2.09
64028A-100	AZ100	66	100	45	10	85	119	18	2.56

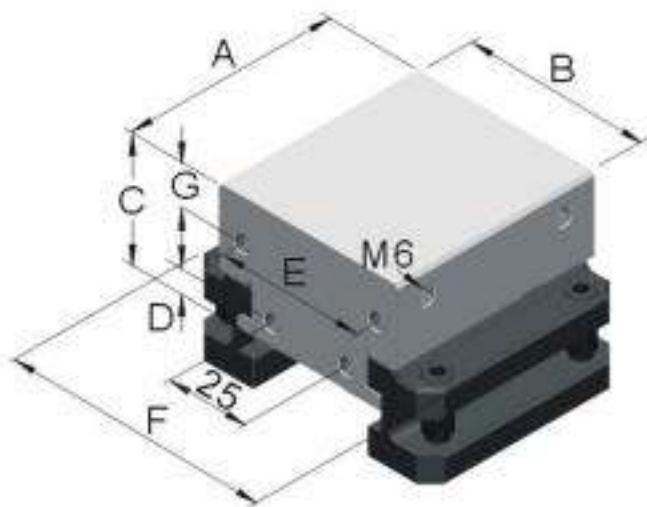

BZ固定鉗口組  
BZ Fixed block

**M** 工具鋼(Tool steel)  
**H** HRC48°~50°

Unit:mm

訂購編號 Order No.	型號 Model	A	B	C	D	E	F	G	N.W.(kg)
64030B-048	BZ048	50	48	40	8	35	81	14	1.05
64030B-060	BZ060	50	60	40	8	45	81	14	1.17
64030B-080	BZ080	60	80	45	10	65	99	18	1.90
64030B-100	BZ100	60	100	45	10	85	119	18	2.33

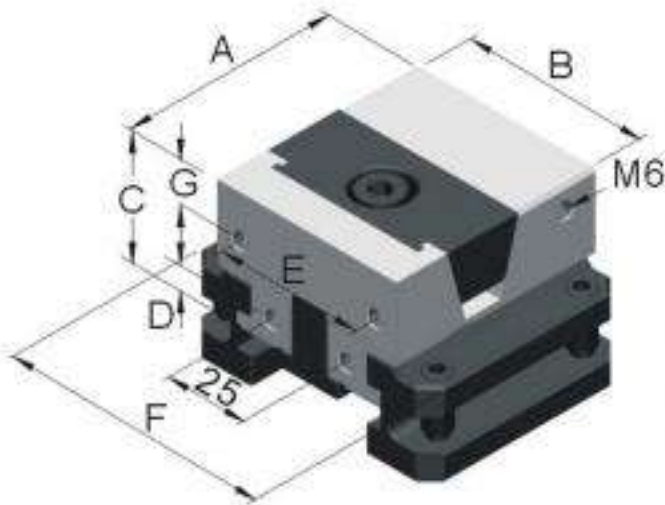

KA單向平行夾持鉗口組  
KA One-side lockdown

**M** 工具鋼(Tool steel)  
**H** HRC43°~45°

Unit:mm

訂購編號 Order No.	型號 Model	A	B	C	D	E	F	G	N.W.(kg)
64032A-048	KA048	66	48	40	8	35	81	14	1.33
64032A-060	KA060	66	60	40	8	45	81	14	1.49
64032A-080	KA080	72	80	45	10	65	99	18	2.24
64032A-100	KA100	72	100	45	10	85	119	18	2.74

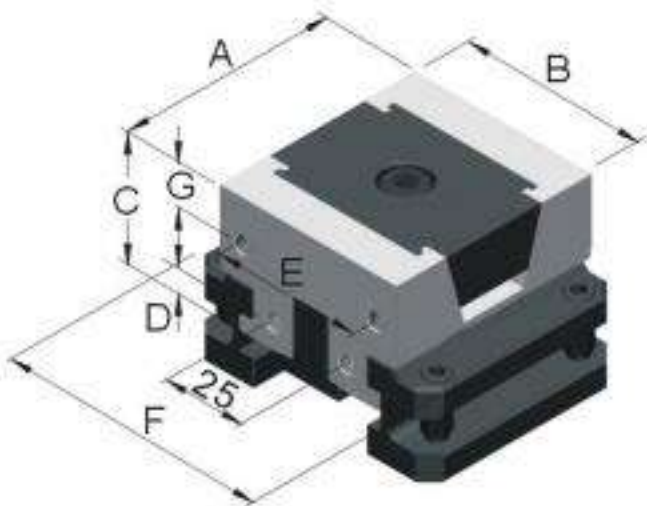

KB雙向平行夾持鉗口組  
KB Dual-side lockdown

**M** 工具鋼(Tool steel)  
**H** HRC43°~45°

Unit:mm

訂購編號 Order No.	型號 Model	A	B	C	D	E	F	G	N.W.(kg)
64034B-048	KB048	50	48	40	8	35	81	14	1.00
64034B-060	KB060	50	60	40	8	45	81	14	1.11
64034B-080	KB080	60	80	45	10	65	99	18	1.82
64034B-100	KB100	60	100	45	10	85	119	18	2.23

## 標準固定夾持件 Standard Clamps

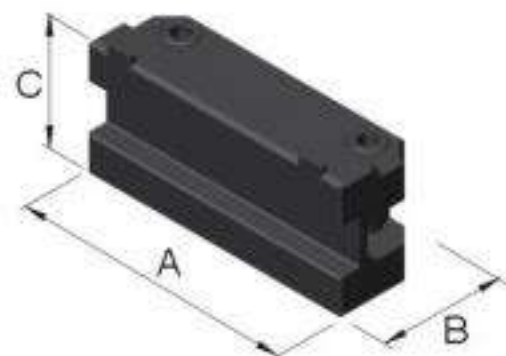

K型夾持塊  
K Clamp

**M** SNCM439  
**H** HRC30°

Unit:mm

訂購編號 Order No.	型號 Model	A	B	C	N.W.(kg)
64044A-001	KA	65	21.5	31.7	0.23
64044A-002	KB	49	21.5	31.7	0.17

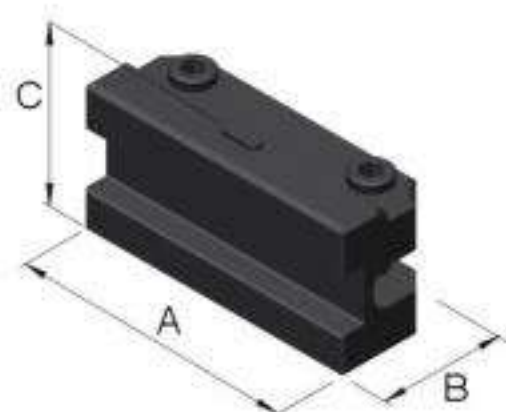

K型夾持塊  
K Clamp

**M** SNCM439  
**H** HRC30°

Unit:mm

訂購編號 Order No.	型號 Model	A	B	C	N.W.(kg)
64045K-001	KN	58	21.5	30.3	0.21

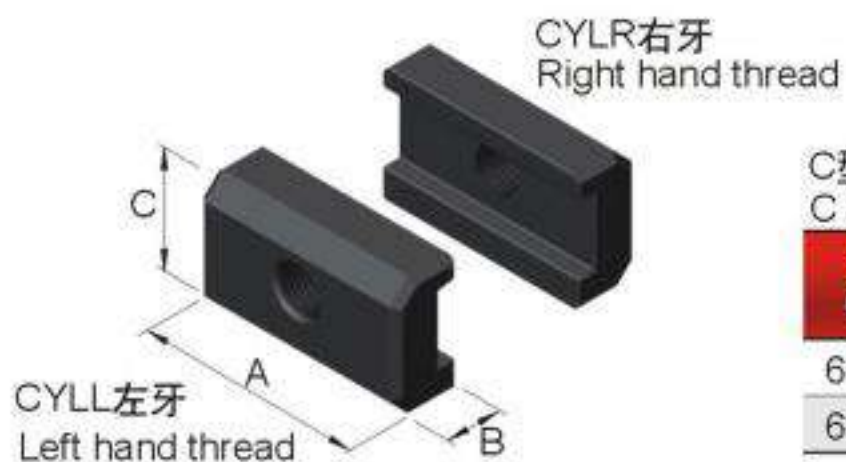

C型夾持塊  
C Clamp

**M** 工具鋼(Tool steel)  
**H** HRC28°~34°  
**S** QPQ HV950°

Unit:mm

訂購編號 Order No.	型號 Model	A	B	C	N.W.(kg)
64046C-001	CYLR	58	17.5	35	0.21
64046C-002	CYLL	58	17.5	35	0.21

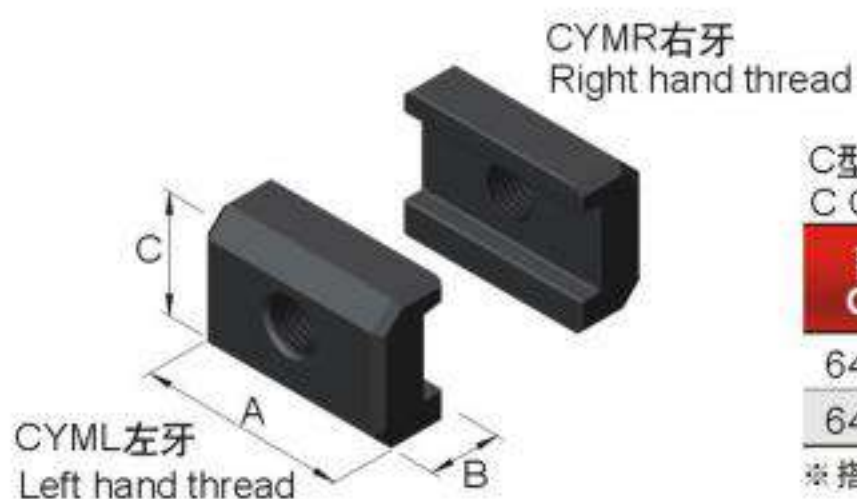

C型夾持塊  
C Clamp

**M** 工具鋼(Tool steel)  
**H** HRC28°~34°  
**S** QPQ HV950°

Unit:mm

訂購編號 Order No.	型號 Model	A	B	C	N.W.(kg)
64048C-001	CYMR	48	17.5	35	0.17
64048C-002	CYML	48	17.5	35	0.17

※ 搭配精密快速求心虎鉗使用 ※ Compatible for PQV204V use

## 標準鉗口組件與固定夾持件 Standard Clamps and Blocks

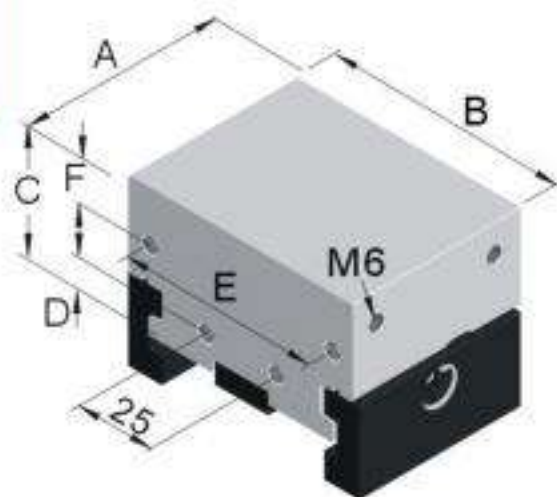

CZ固定鉗口組  
CZ Fixed block

**M** 工具鋼(Tool steel)  
**H** HRC48°~50°

Unit:mm

訂購編號 Order No.	型號 Model	A	B	C	D	E	F	N.W.(kg)
64066-080	CZ080	60	80	45	10	65	18	1.81
64066-100	CZ100	60	100	45	10	85	18	2.24

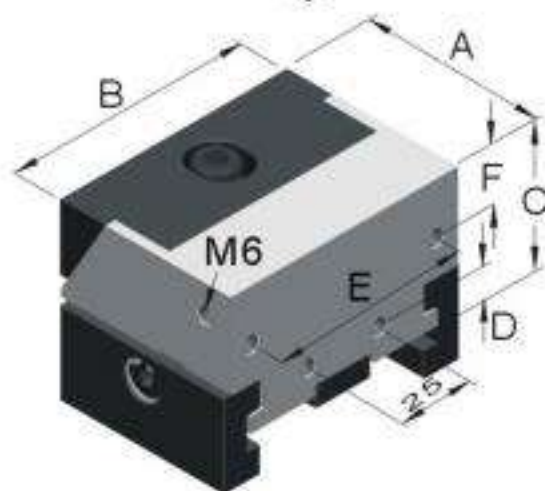

CC單口下拉夾持鉗口組  
CC One-side lockdown

**M** 工具鋼(Tool steel)  
**H** HRC48°~50°

Unit:mm

訂購編號 Order No.	型號 Model	A	B	C	D	E	F	N.W.(kg)
64072-080	CC080	60	80	45	10	65	18	1.69
64072-100	CC100	60	100	45	10	85	18	2.12

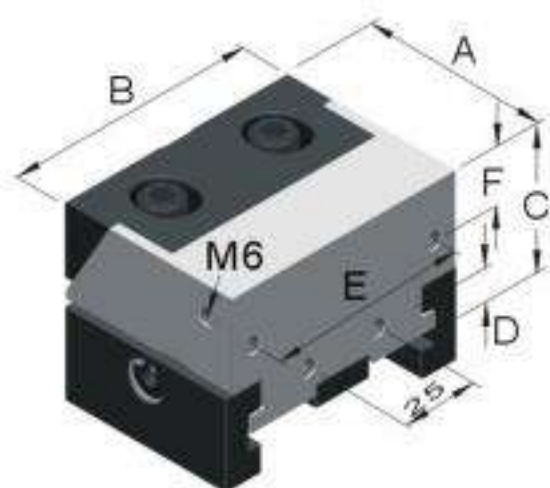

CD雙口下拉夾持鉗口組  
CD Dual-side lockdown

**M** 工具鋼(Tool steel)  
**H** HRC48°~50°

Unit:mm

訂購編號 Order No.	型號 Model	A	B	C	D	E	F	N.W.(kg)
64074-080	CD080	60	80	45	10	65	18	1.67
64074-100	CD100	60	100	45	10	85	18	2.09

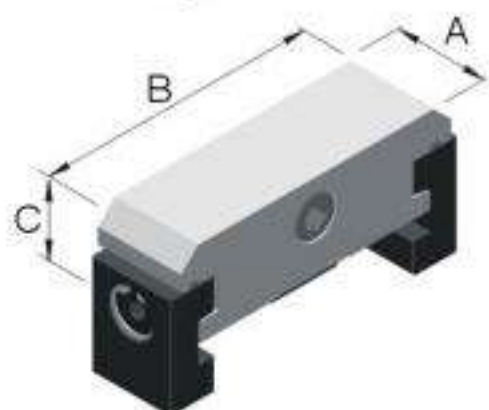

CE固定塊組  
CE Fixed block

**M** 工具鋼(Tool steel)  
**H** HRC28°~34°  
**S** QPQ HV950°

Unit:mm

訂購編號 Order No.	型號 Model	A	B	C	N.W.(kg)
64078-080	CE080	24	78	25	1.85
64078-100	CE100	24	98	25	2.27

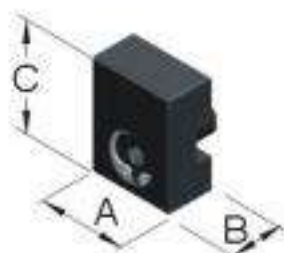

C型夾持塊  
C Clamp

**M** 工具鋼(Tool steel)  
**H** HRC28°~34°  
**S** QPQ HV950°

Unit:mm

訂購編號 Order No.	型號 Model	A	B	C	N.W.(kg)
64090-001	CS	23	13	29.5	0.05

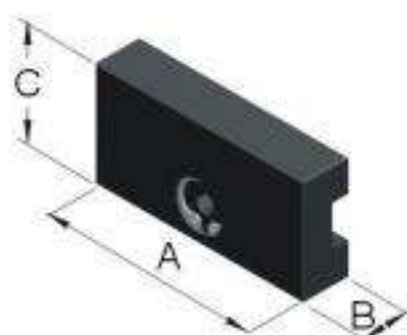

C型夾持塊  
C Clamp

**M** 工具鋼(Tool steel)  
**H** HRC28°~34°  
**S** QPQ HV950°

Unit:mm

訂購編號 Order No.	型號 Model	A	B	C	N.W.(kg)
64090-002	CM	48	13	29.5	0.11
64090-003	CL	58	13	29.5	0.21

# 並列式虎鉗特別附件 (選購品)

Accessories (Optional)



基準靠板 (M6牙)  
Datum Plate (M6 thread)

**M** 工具鋼 (Tool steel)  
**H** HRC45°

Unit: mm

訂購編號 Order No.	型號 Model	A	B	C	N.W.(kg)
64100-38	DPM048060	38	9.5	16	0.05

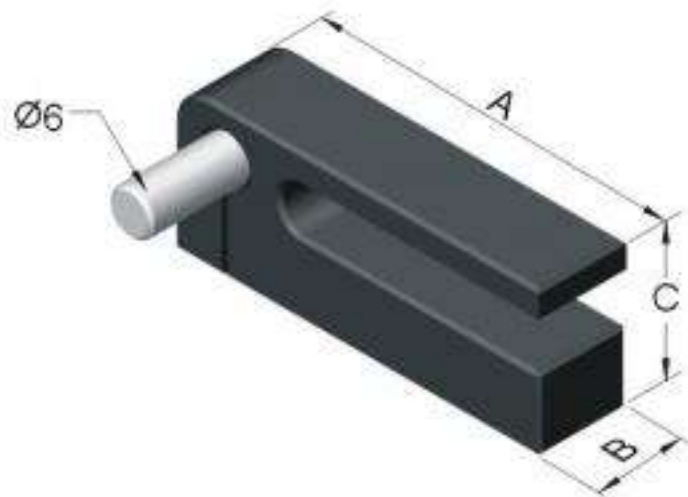

基準靠板 (孔)  
Datum Plate (Pin Hole)

**M** 工具鋼 (Tool steel)  
**H** HRC45°

Unit: mm

訂購編號 Order No.	型號 Model	A	B	C	N.W.(kg)
64110-50	DPD048060	50	12	20	0.05
64110-60	DPD080100	60	12	20	0.06

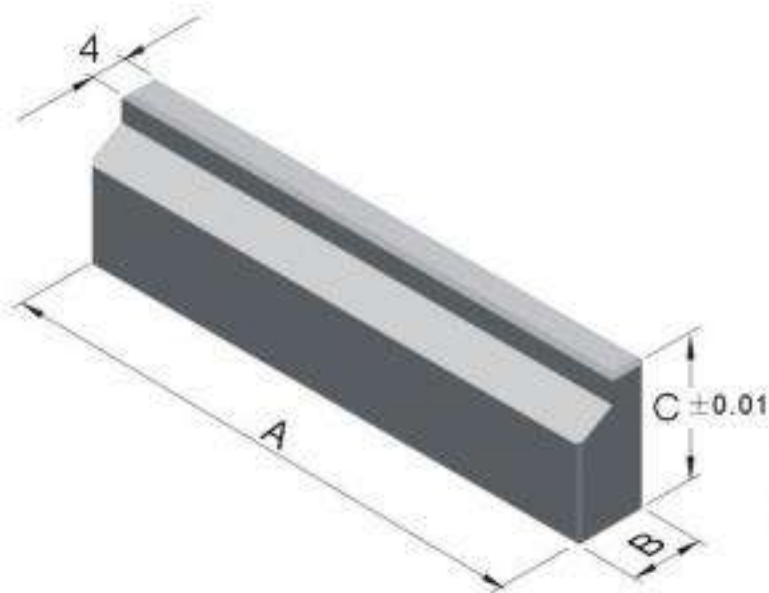

平行墊板  
Parallels

**M** 工具鋼 (Tool steel)  
**H** HRC45°

Unit: mm

訂購編號 Order No.	型號 Model	A	B	C	N.W.(kg)
64120-04835	MP04835	48	8	35	0.05
64120-04838	MP04838			38	0.07
64120-06035	MP06035	60	8	35	0.06
64120-06038	MP06038			38	0.09
64120-08040	MP08040	80	8	40	0.09
64120-08043	MP08043			43	0.12
64120-10040	MP10040	100	8	40	0.12
64120-10043	MP10043			43	0.16

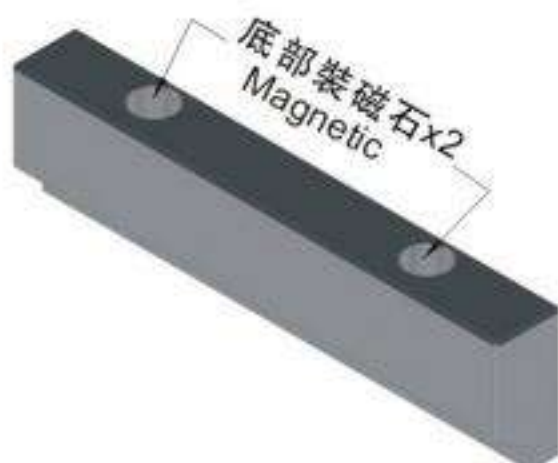

## 並列式虎鉗特別附件 (選購品) Accessories (Optional)

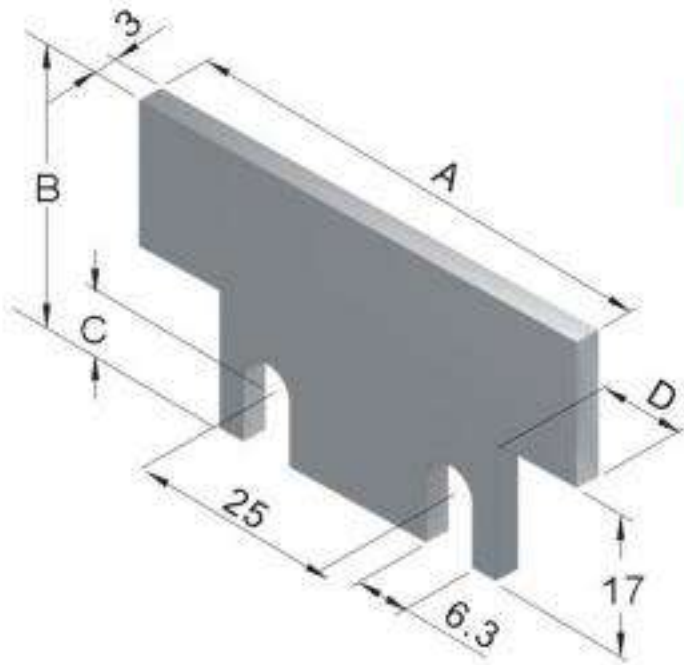

墊板  
Spacer

**M** 工具鋼 (Tool steel)  
**H** HRC45°

Unit:mm

訂購編號 Order No.	型號 Model	A	B	C	D	N.W.(kg)
64130-04835	SP04835	47.8	35	8	5	0.04
64130-04838	SP04838		38			0.05
64130-06035	SP06035	59.8	35	8	11	0.06
64130-06038	SP06038		38			0.07
64130-08040	SP08040	79.8	40	10	12	0.10
64130-08043	SP08043		43			0.10
64130-10040	SP10040	99.8	40	10	12	0.13
64130-10043	SP10043		43			0.14

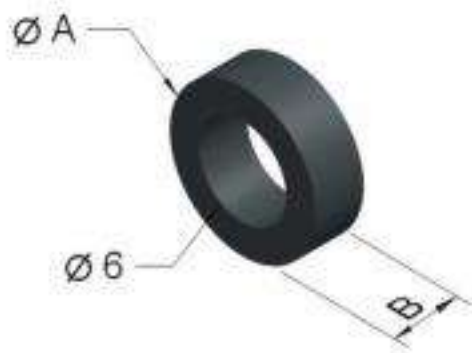

墊圈  
Spacer

**M** 工具鋼 (Tool steel)  
**H** HRC45°

Unit:mm

訂購編號 Order No.	型號 Model	A	B	C
64140-A	SPACER-A	10	3.5	用於A型, 使用2個 MKS-A, 2 pcs
64140-B	SPACER-B		2	用於B型, 使用4個 MKS-A, 4 pcs

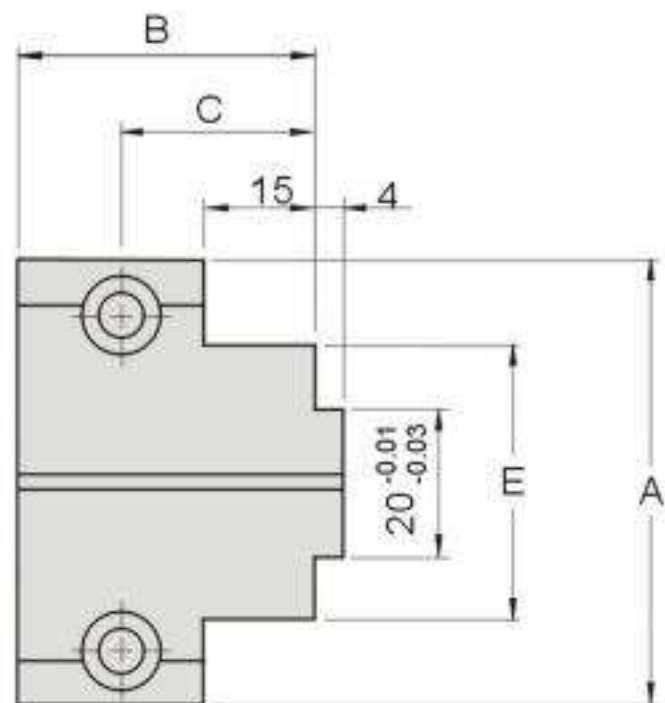
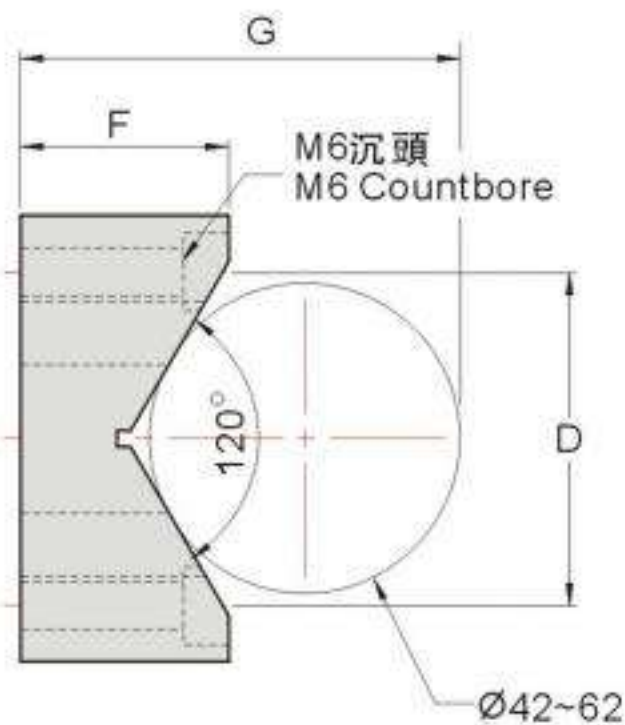

V型鉗口(A型B型用)  
V-Clamp(for MKS-A & B)

**M** 工具鋼 (Tool steel)  
**H** HRC48°~50°

Unit:mm

訂購編號 Order No.	型號 Model	A	B	C	D	E	F	G	CLAMP(MAX)	N.W.(kg)
64160-048	JAW-048	48	40	26	35	37	23	57.279	Ø70	0.28
64160-060	JAW-060	60	40	26	45	37	28	59.392	Ø90	0.42
64160-080	JAW-080	80	45	27	65	55	38	86.032	Ø125	0.86
64160-100	JAW-100	100	45	27	85	75	48	91.124	Ø160	1.36

## ■ 技術領先 品質絕佳 零配件的首選

高自製率 · 30年製造經驗 · 設備領先齊全

自1988年成立以來，精展一直致力於提高生產效率和產品質量，以滿足客戶的需求。我們的產品覆蓋面和品種不斷創新和改進，不僅保持了同樣的質量性能，而且在市場上具有競爭優勢。

精展主要生產磨床、銑床等工具機配件和模具零配件。因客戶的信賴及支持，更因應客戶的需求，我們推出了【模組化並列式虎鉗】系列產品，提供多種夾緊解決方案。領先的技術水平，先進的加工設備，優異、穩定的表現深獲客戶贊譽。

精展歷經磨練，立於行業之巔，以貼心服務客戶的設計理念。協助客戶提高生產效率，降低製造成本。精展精密，最值得信賴的零配件製造商。

[品質、信用、可靠、專業]是精展堅持貫徹的經營理念，我們懷抱貢獻產業的使命，不斷成長茁壯，用前瞻視野洞悉客戶未來需求，期許以多年的專業經驗與突破性的創新動力，提供更高效率、節能的零配件產品，協助客戶開創未來競爭力，精展總是為您想的更多。

總經理 /



### 加工設備

- CNC 臥式加工中心機 (300mm 四方工作盤 x 10座)
- CNC 臥式加工中心機 (400mm 四方工作盤 x 10座)
- CNC 臥式加工中心機 (400mm 四方工作盤 x 2座)
- CNC 臥式加工中心機 (400mm 四方工作盤 x 24座)
- CNC 五面加工中心機 (400mm 四方工作盤 x 2座)
- CNC 五面加工中心機 (300mm 四方工作盤 x 10座)
- CNC 五軸同動加工中心機 (150 x 150mm 盤 x 180座)
- CNC 立式加工中心機 (400 x 800mm 盤)
- CNC 立式加工中心機 (500 x 1000mm 盤)
- CNC 四軸車銑複合加工機
- CNC 七軸車銑複合加工機
- CNC 九軸車銑複合加工機
- 立式銑床 (2馬力)
- 立式銑床 (1.5馬力)
- CNC 自動車床
- 手動車床
- 無心磨床
- 外圓磨床
- 桌上型內外圓磨床
- CNC 平面磨床
- 手動平面磨床
- 三軸自動平面磨床
- 自動內孔磨床
- CNC 三軸外圓磨床
- CNC 五軸外圓磨床
- CNC 雙軸內孔磨床



# Memo

A sheet of memo paper with a red header at the top right containing the word "Memo" in white. Below the header, the page is filled with horizontal dashed lines for writing. The lines are evenly spaced and extend across the width of the page.



Copyright © Gin Tech Precision Co., Ltd. All Rights Reserved

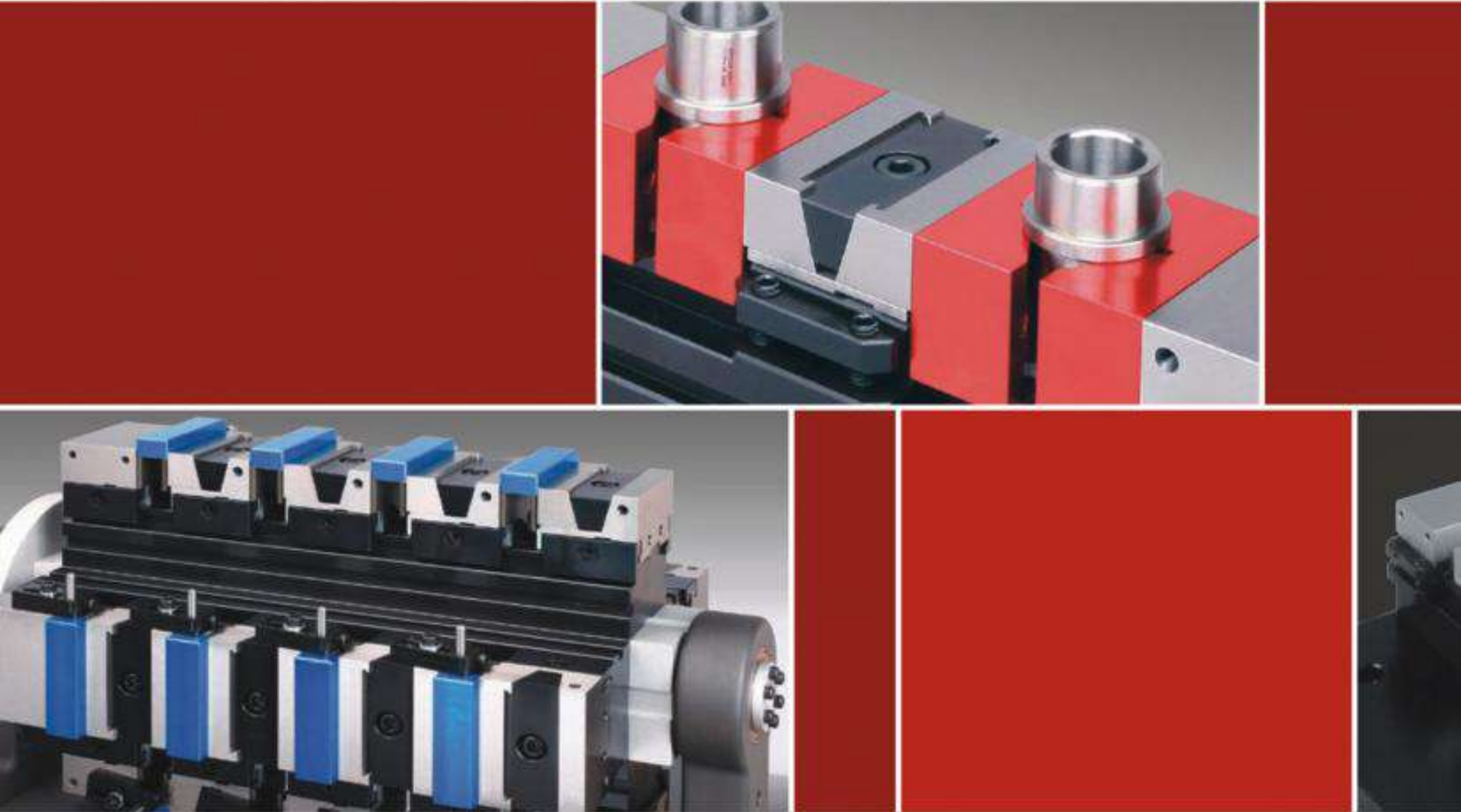

\*\*Gin Tech reserves right to amend the product content without prior notice\*\*

**精展精密科技股份有限公司(總公司)  
GIN TECH PRECISION CO., LTD.**

台灣238新北市樹林區保安街一段341巷7號  
Address: No 7, Lane 341, Sec. 1, Bau An Street, Shu lin Dist.,  
23841, New Taipei City, Taiwan  
TEL: 886-2-2681-8596 (Rep.)       Sales@ginchan.com.tw  
FAX: 886-2-2681-8516               www.gin-chan.com

**東莞美商精展機械五金有限公司  
東莞市精展機械五金有限公司  
GIN CHAN MACHINERY & HARDWARE CO., LTD.(DONGGUAN)**

廣東省東莞市大朗鎮石厦村金沙崗二路27號  
TEL : 86-769-8318-5858 (Rep.)  
FAX: 86-769-8318-5838/8313-5003  
 www.ginchan.com.cn       sales@ginchan.com.cn



Scan Now!

