

刀具系列



I01-I40

切削工具 Cutting Tools

切削工具

萬用型修整組合.....	I01~I02
無刮痕修整刀具.....	I03
迷你型陶瓷刮刀.....	I04~I05
超細致修整刮刀.....	I06



切削工具

快速鑽頭.....	I13~I26
高速粗搪刀.....	I27
定值粗搪刀.....	I28
倒角銑刀架.....	I29~I30



切削工具

直角高速銑刀架.....	I31~I33
圓刃銑刀架.....	I34
直角高速銑刀架.....	I35~I38
殼型銑刀架.....	I39~I40



INDEX

I01~06

修整工具



67000 I01



67010~14 I03



68020~24 I04



68030~34 I05



68040~46 I06

I13~28

銑床用快速鑽頭



68140 I15



68150 I17



68160 I19



68170 I21



68180 I23



68190 I24



68210 I25



68220 I26

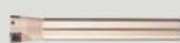

68230 I27



68240 I28

I29~40

銑床用面銑刀具



68250 I29



68280 I30



68290 I30



68300 I31

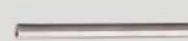

68310 I32



68320 I33



68330 I34



68340 I34



68350 I35



68370 I36

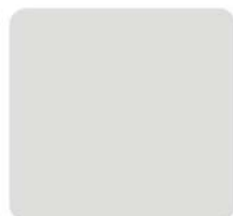

68390 I37



68400 I38



68410 I39



68420 I40

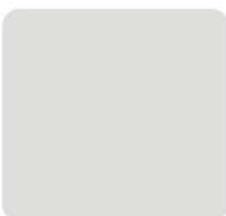
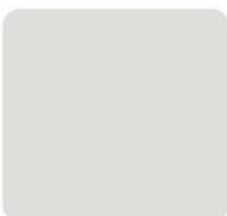
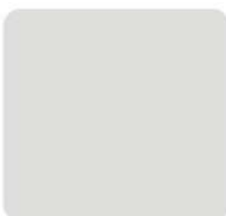
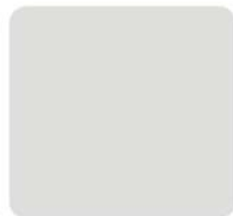

修整工具 Deburring Tool

67000

RG1000

手持萬用修整組合 NOGA MULTIBURR SET

開啓
控制桿



S10 Blade

67000-01 BS1010

適用工作物包括：鋼鐵制品、鋁制品及塑膠制品

D50 ScraperBlade

67000-02 BD5010

適用於工具及模組加工業

N2 Blade

67000-03 BN2010

適用於銅及鑄鐵工作物

Rotodrive Countersink Blade

67000-04 BC1041

回轉式單刃面取刀刃

範圍“1mm~10.4mm面取倒角90°”

每款工具均具有各自
開啓控制桿



使用範例：

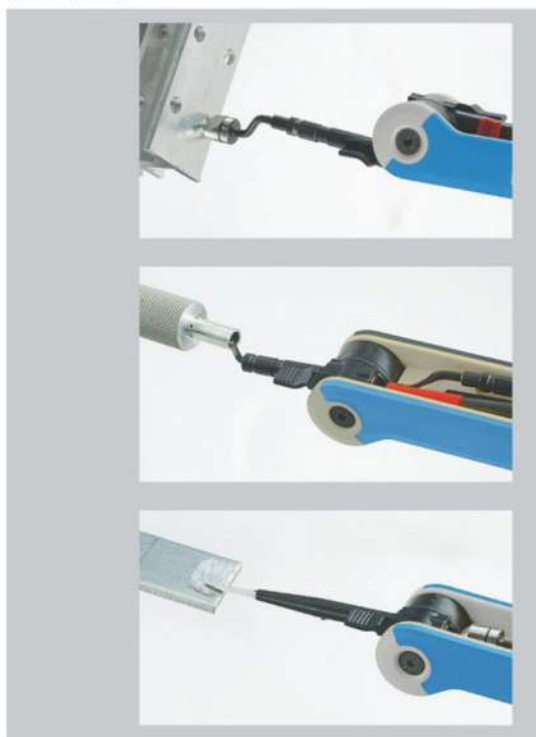

★每組均僅附有以上刀刃各1支

MULTIBURR

RG1000

手持萬用修整組合，內有多種刀刃，可運用於更廣泛更完美的修整面。

創新獨特的收納設計，工具中附有4款可折疊式刀具，可輕易收納及展開並鎖定，更增加使用的安全性，讓你隨時隨地攜帶使用。

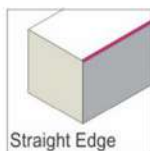

Straight Edge



Bushing Scraping

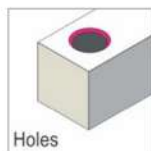

Holes

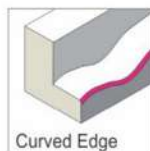

Curved Edge

去毛刺系列示意圖 Demonstration for Deburring Systems



修整工具
DRESSING TOOL

修整工具 Deburring Tool

67010

NG1910

無刮痕修整刀具 Tool With Non Scratch Blade



Non Scratch 無刮痕刀刃系列

NG1910

新款無刮痕修整刀具(刀刃附有安全護蓋設計)

在工件上去除毛邊時,有時會留下難看的刮痕,NOGA將NG-1握柄與新的無刮痕刀片結合安全護蓋,來防止摩擦,進而消除刮痕。最適用於鋼鐵、鋁和塑料的工件上作業。



包含:

67012

NG1000

NG1000 握柄

符合人體工學設計的握柄



67014

BS9110

BS9110

無刮痕HSS材質刀刃與安全護蓋(10支裝)
塑膠安全護蓋可以保護工件表面避免刮痕



67020

CR1500

迷你型陶瓷和凸面陶瓷刀刃

Mini Ceramic Handle and Convexed Blade

Ceramic Tool 陶瓷修整工具

CR1500

迷你型陶瓷和凸面陶瓷刀刃

適用於所有塑膠材質和軟性材質上,用於表面修刮與分界線上毛邊清除,刀刃可替換。



67022

CR1400

包含:

CR1400 迷你型專用握把

獨特設計的迷你型專用握把,刀刃可替換,另備有刀刃儲存的空間。



67024

CR1550

CR1550 迷你凸面陶瓷刀刃

適用於表面修刮和細小分界線上實施毛邊刮除作業。

取下刀片

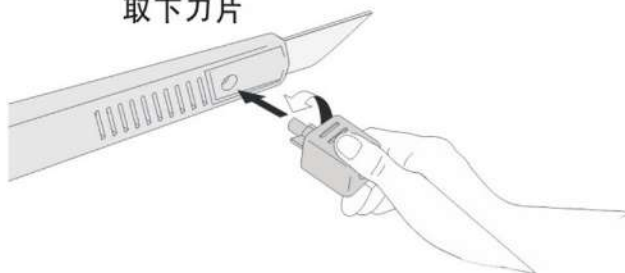

裝入刀片

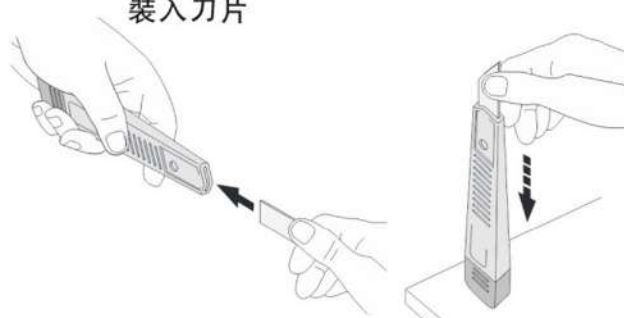

修整工具 Deburring Tool

67030

CR4100

可調式陶瓷迷你三角刮刀

Adjustable Ceramic Mini Scraper

Ceramic Tool 陶瓷修整工具

CR4100

可調式陶瓷迷你三角刮刀

陶瓷迷你三角刮刀適用於各式塑料上的表面清潔和分界線上毛邊去除,特殊刀刃安全設計。



67032

YT10004

包含:

YT10004可調式迷你刮刀握把

範圍: 2.2~4.5mm



67034

CR4500

CR4500 迷你陶瓷三角刀刃

尺寸: 4x50mm



67040

FT3000

超細致修整刮刀 NOGA Micro Deburring Set



FT3000

精緻修整工具組

內含:

FT10001

FT11001

FT12001

(以上刀刃均無法替換)



67041

FT10001

FT10001 超細致修整刮刀

舒適設計的握柄搭配專業細致作業用HSS刀刃S-150



67042

FT11001

FT11001 迷你三角刮刀

舒適設計的握柄搭配精緻三角HSS迷你刮刀D50



67043

FT12001

FT12001 迷你回轉式面取修刀

針對0~3mm小孔徑的毛邊修整搭配3.2mm回轉式面取刀刃

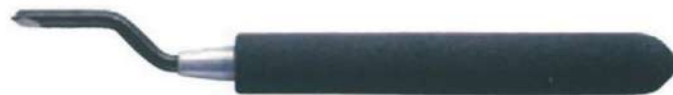

切削工具 Cutting Tool

68140

WDX-2D

捨棄式快速鑽頭(2倍長) Rapid Drill (2D)

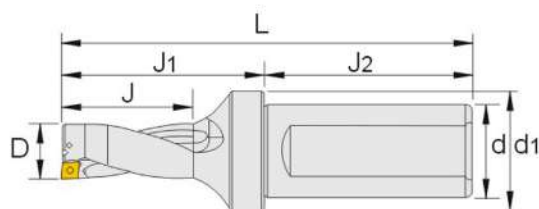

90° 單位:mm

訂購編號 Order No.	型號 Model	刃徑 D	全長 L	刃長 J	刃長1 J1	柄長 J2	柄徑 d	外徑 d1	最大 偏移量	刀片類型 Inserts	扳手 Wrench	螺絲 Screw
68140-01	WDX13 -C25-2D-26L	13	106	26	50	56	25	32	0.35	WDX042004	T6	M1.8-3.0-2.4-60
68140-02	WDX13.5-C25-2D-28L	13.5	106	27	50	56	25		0.30			
68140-03	WDX14 -C25-2D-28L	14	108	28	52	56	25		0.25			
68140-04	WDX14.5-C25-2D-30L	14.5	108	29	52	56	25		0.20			
68140-05	WDX15 -C25-2D-30L	15	110	30	54	56	25		0.15			
68140-06	WDX15.5-C25-2D-32L	15.5	110	31	54	56	25		0.40	WDX052504	T6	M2.0-5.0-2.7-60
68140-07	WDX16 -C25-2D-32L	16	112	32	56	56	25		0.40			
68140-08	WDX16.5-C25-2D-34L	16.5	112	33	56	56	25		0.35			
68140-09	WDX17 -C25-2D-34L	17	114	34	58	56	25		0.30			
68140-10	WDX17.5-C25-2D-36L	17.5	114	35	58	56	25		0.25			
68140-11	WDX18 -C25-2D-36L	18	116	36	60	56	25		0.20	WDX063006	T7	M2.2-5.5-3.4-60
68140-12	WDX18.5-C25-2D-38L	18.5	116	37	60	56	25		0.50			
68140-13	WDX19 -C25-2D-38L	19	118	38	62	56	25		0.45			
68140-14	WDX19.5-C25-2D-40L	19.5	118	39	62	56	25		0.40			
68140-15	WDX20 -C25-2D-40L	20	120	40	64	56	25		0.30			
68140-16	WDX20.5-C25-2D-42L	20.5	120	41	64	56	25	0.30	WDX073506	T8	M2.5-6.0-3.5-60	
68140-17	WDX21 -C25-2D-42L	21	122	42	66	56	25	0.20				
68140-18	WDX21.5-C25-2D-44L	21.5	122	43	66	56	25	0.15				
68140-19	WDX22 -C25-2D-44L	22	124	44	68	56	25	0.10				
68140-20	WDX22.5-C25-2D-46L	22.5	124	45	68	56	25	0.05				
68140-21	WDX23 -C25-2D-46L	23	126	46	70	56	25	0.70	38.5	WDX073506	T8	M2.5-6.0-3.5-60
68140-22	WDX23.5-C32-2D-47L	23.5	130	47	70	60	32	0.70				
68140-23	WDX24 -C32-2D-48L	24	132	48	72	60	32	0.60				
68140-24	WDX24.5-C32-2D-50L	24.5	132	49	72	60	32	0.50				
68140-25	WDX25 -C32-2D-50L	25	134	50	74	60	32	0.50				
68140-26	WDX25.5-C32-2D-52L	25.5	134	51	74	60	32	0.45				
68140-27	WDX26 -C32-2D-52L	26	141	52	81	60	32	0.40				
68140-28	WDX26.5-C32-2D-54L	26.5	141	53	81	60	32	0.35				
68140-29	WDX27 -C32-2D-54L	27	143	54	83	60	32	0.25				
68140-30	WDX27.5-C32-2D-56L	27.5	143	55	83	60	32	0.20				
68140-31	WDX28 -C32-2D-56L	28	145	56	85	60	32	0.15				
68140-32	WDX28.5-C32-2D-58L	28.5	145	57	85	60	32	0.10				

68140
WDX-2D
捨棄式快速鑽頭(2倍長) Rapid Drill (2D)

單位:mm

訂購編號 Order No.	型號 Model	刃徑 D	全長 L	刃長 J	刃長1 J1	柄長 J2	柄徑 d	外徑 d1	最大 偏移量	刀片類型 Inserts	扳手 Wrench	螺絲 Screw
68140-33	WDX29 -C32-2D-58L	29	147	58	87	60	32	39	1.00	WDXT094008	T15	M3.5-8.0-5.3-60
68140-34	WDX29.5-C32-2D-60L	29.5	147	59	87	60	32		0.95			
68140-35	WDX30 -C32-2D-60L	30	149	60	89	60	32	0.90				
68140-36	WDX31 -C32-2D-62L	31	151	62	91	60	32	0.80				
68140-37	WDX32 -C32-2D-64L	32	153	64	93	60	32	0.70				
68140-38	WDX33 -C32-2D-66L	33	155	66	95	60	32	0.55				
68140-39	WDX34 -C32-2D-68L	34	157	68	97	60	32	0.45				
68140-40	WDX35 -C32-2D-70L	35	159	70	99	60	32	0.35				
68140-41	WDX36 -C32-2D-72L	36	161	72	101	60	32	0.20				
68140-42	WDX37 -C32-2D-74L	37	163	74	103	60	32	1.00				
68140-43	WDX38 -C32-2D-76L	38	165	76	105	60	32	1.00	WDXT125012	T20	M5.0-11.0-7.0-60	
68140-44	WDX39 -C32-2D-78L	39	167	78	107	60	32	0.90				
68140-45	WDX40 -C40-2D-80L	40	179	80	109	70	40	0.80				
68140-46	WDX41 -C40-2D-82L	41	181	82	111	70	40	0.70				
68140-47	WDX42 -C40-2D-84L	42	183	84	113	70	40	0.60				
68140-48	WDX43 -C40-2D-86L	43	185	86	115	70	40	0.50				
68140-49	WDX44 -C40-2D-88L	44	187	88	117	70	40	0.50				
68140-50	WDX45 -C40-2D-90L	45	189	90	119	70	40	0.40				
68140-51	WDX46 -C40-2D-92L	46	197	92	127	70	40	1.50				
68140-52	WDX47 -C40-2D-94L	47	199	94	129	70	40	1.40				
68140-53	WDX48 -C40-2D-96L	48	201	96	131	70	40	1.30	WDXT156012	T25	M6.0-15.0-9.0-60	
68140-54	WDX49 -C40-2D-98L	49	203	98	133	70	40	1.20				
68140-55	WDX50 -C40-2D-100L	50	205	100	135	70	40	1.10				
68140-56	WDX51 -C40-2D-102L	51	207	102	137	70	40	1.00				
68140-57	WDX52 -C40-2D-104L	52	209	104	139	70	40	0.90				
68140-58	WDX53 -C40-2D-106L	53	211	106	141	70	40	0.80				
68140-59	WDX54 -C40-2D-108L	54	213	108	143	70	40	0.60				
68140-60	WDX55 -C40-2D-110L	55	215	110	145	70	40	0.50				
68140-61	WDX56 -C40-2D-112L	56	220	112	150	70	40	2.00				
68140-62	WDX57 -C40-2D-114L	57	222	114	152	70	40	1.80				WDXT186012
68140-63	WDX58 -C40-2D-116L	58	224	116	154	70	40	1.70				
68140-64	WDX59 -C40-2D-118L	59	226	118	156	70	40	1.60				
68140-65	WDX60 -C40-2D-120L	60	228	120	158	70	40	1.50				
68140-66	WDX61 -C40-2D-122L	61	230	122	160	70	40	1.40				
68140-67	WDX62 -C40-2D-124L	62	232	124	162	70	40	1.30				
68140-68	WDX63 -C40-2D-126L	63	234	126	164	70	40	1.20				
68140-69	WDX64 -C40-2D-128L	64	236	128	166	70	40	1.00				
68140-70	WDX65 -C40-2D-130L	65	238	130	168	70	40	0.90				
68140-71	WDX66 -C40-2D-132L	66	240	132	170	70	40	0.70				
68140-72	WDX67 -C40-2D-134L	67	242	134	172	70	40	0.60				
68140-73	WDX68 -C40-2D-136L	68	244	136	174	70	40	0.50				



 切削工具
CUTTING TOOL

切削工具 Cutting Tool

68150

WDX-3D

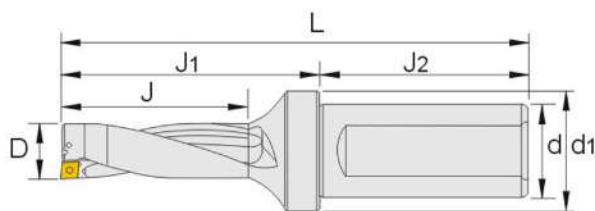
捨棄式快速鑽頭(3倍長) Rapid Drill (3D)



90° 單位:mm

訂購編號 Order No.	型號 Model	刃徑 D	全長 L	刃長 J	刃長1 J1	刃長2 J2	柄長 柄徑 d	外徑 d1	最大 偏移量	刀片類型 Inserts	扳手 Wrench	螺絲 Screw
68150-01	WDX13 -C25-3D-39L	13	119	39	63	56	25		0.35	WDXTO42004	T6	M1.8-3.0-2.4-60
68150-02	WDX13.5-C25-3D-40.5L	13.5	119	40.5	63	56	25		0.30			
68150-03	WDX14 -C25-3D-42L	14	122	42	66	56	25		0.25			
68150-04	WDX14.5-C25-3D-43.5L	14.5	122	43.5	66	56	25		0.20			
68150-05	WDX15 -C25-3D-45L	15	125	45	69	56	25		0.15			
68150-06	WDX15.5-C25-3D-46.5L	15.5	125	46.5	69	56	25		0.40	WDXTO52504	T6	M2.0-5.0-2.7-60
68150-07	WDX16 -C25-3D-48L	16	128	48	72	56	25		0.40			
68150-08	WDX16.5-C25-3D-49.5L	16.5	128	49.5	72	56	25		0.35			
68150-09	WDX17 -C25-3D-51L	17	131	51	75	56	25		0.30			
68150-10	WDX17.5-C25-3D-52.5L	17.5	131	52.5	75	56	25		0.25			
68150-11	WDX18 -C25-3D-54L	18	134	54	78	56	25	32	0.20	WDXTO63006	T7	M2.2-5.5-3.4-60
68150-12	WDX18.5-C25-3D-55.5L	18.5	134	55.5	78	56	25		0.50			
68150-13	WDX19 -C25-3D-57L	19	137	57	81	56	25		0.45			
68150-14	WDX19.5-C25-3D-58.5L	19.5	137	58.5	81	56	25		0.40			
68150-15	WDX20 -C25-3D-60L	20	140	60	84	56	25		0.30			
68150-16	WDX20.5-C25-3D-61.5L	20.5	140	61.5	84	56	25		0.30	WDXTO73506	T8	M2.5-6.0-3.5-60
68150-17	WDX21 -C25-3D-63L	21	143	63	87	56	25		0.20			
68150-18	WDX21.5-C25-3D-64.5L	21.5	143	64.5	87	56	25		0.15			
68150-19	WDX22 -C25-3D-66L	22	146	66	90	56	25		0.10			
68150-20	WDX22.5-C25-3D-67.5L	22.5	146	67.5	90	56	25		0.05			
68150-21	WDX23 -C25-3D-69L	23	149	69	93	56	25		0.70	WDXTO73506	T8	M2.5-6.0-3.5-60
68150-22	WDX23.5-C32-3D-70.5L	23.5	149	70.5	93	60	32	38.5	0.70			
68150-23	WDX24 -C32-3D-72L	24	156	72	96	60	32		0.60			
68150-24	WDX24.5-C32-3D-73.5L	24.5	156	73.5	96	60	32		0.50			
68150-25	WDX25 -C32-3D-75L	25	159	75	99	60	32		0.50			
68150-26	WDX25.5-C32-3D-76.5L	25.5	159	76.5	99	60	32		0.45			
68150-27	WDX26 -C32-3D-78L	26	167	78	107	60	32		0.40			
68150-28	WDX26.5-C32-3D-79.5L	26.5	167	79.5	107	60	32		0.35			
68150-29	WDX27 -C32-3D-81L	27	170	81	110	60	32		0.25			
68150-30	WDX27.5-C32-3D-82.5L	27.5	170	82.5	110	60	32		0.20			
68150-31	WDX28 -C32-3D-84L	28	173	84	113	60	32		0.15			
68150-32	WDX28.5-C32-3D-85.5L	28.5	173	85.5	113	60	32		0.10			

切削工具
CUTTING TOOL

68150
WDX-3D
捨棄式快速鑽頭(3倍長) Rapid Drill (3D)

單位:mm

訂購編號 Order No.	型號 Model	刃徑 D	全長 L	刃長 J	刃長1 J1	柄長 J2	柄徑 d	外徑 d1	最大 偏移量	刀片類型 Inserts	扳手 Wrench	螺絲 Screw			
68150-33	WDX29 -C32-3D-87L	29	176	87	116	60	32	38.5	1.00	WDXT094008	T15	M3.5-8.0-5.3-60			
68150-34	WDX29.5-C32-3D-88.5L	29.5	176	88.5	119	60	32		0.95						
68150-35	WDX30 -C32-3D-90L	30	179	90	119	60	32		0.90						
68150-36	WDX31 -C32-3D-93L	31	182	93	122	60	32		0.80						
68150-37	WDX32 -C32-3D-96L	32	185	96	125	60	32		0.70						
68150-38	WDX33 -C32-3D-99L	33	188	99	128	60	32		0.55						
68150-39	WDX34 -C32-3D-102L	34	191	102	131	60	32		0.45						
68150-40	WDX35 -C32-3D-105L	35	194	105	134	60	32		0.35						
68150-41	WDX36 -C32-3D-108L	36	197	108	137	60	32		0.20						
68150-42	WDX37 -C32-3D-111L	37	200	111	140	60	32		1.00						
68150-43	WDX38 -C32-3D-114L	38	203	114	143	60	32	1.00							
68150-44	WDX39 -C32-3D-117L	39	206	117	146	60	32	0.90							
68150-45	WDX40 -C40-3D-120L	40	219	120	149	70	40	48	0.80	WDXT125012	T20	M5.0-11.0-7.0-60			
68150-46	WDX41 -C40-3D-123L	41	222	123	152	70	40		0.70						
68150-47	WDX42 -C40-3D-126L	42	225	126	155	70	40		0.60						
68150-48	WDX43 -C40-3D-129L	43	228	129	158	70	40		0.50						
68150-49	WDX44 -C40-3D-132L	44	231	132	161	70	40		0.50						
68150-50	WDX45 -C40-3D-135L	45	234	135	164	70	40		0.40						
68150-51	WDX46 -C40-3D-138L	46	243	138	173	70	40		1.50						
68150-52	WDX47 -C40-3D-141L	47	246	141	176	70	40		1.40						
68150-53	WDX48 -C40-3D-144L	48	249	144	179	70	40		1.30						
68150-54	WDX49 -C40-3D-147L	49	252	147	182	70	40		1.20						
68150-55	WDX50 -C40-3D-150L	50	255	150	185	70	40	54	1.10	WDXT156012	T25	M6.0-15.0-9.0-60			
68150-56	WDX51 -C40-3D-153L	51	258	153	188	70	40		1.00						
68150-57	WDX52 -C40-3D-156L	52	261	156	191	70	40		0.90						
68150-58	WDX53 -C40-3D-159L	53	264	159	194	70	40		0.80						
68150-59	WDX54 -C40-3D-162L	54	267	162	197	70	40		0.60						
68150-60	WDX55 -C40-3D-165L	55	270	165	200	70	40		0.50						
68150-61	WDX56 -C40-3D-168L	56	276	168	206	70	40		2.00						
68150-62	WDX57 -C40-3D-171L	57	279	171	209	70	40		55				1.80		
68150-63	WDX58 -C40-3D-174L	58	282	174	212	70	40		56				1.70		
68150-64	WDX59 -C40-3D-177L	59	285	177	215	70	40		57				1.60		
68150-65	WDX60 -C40-3D-180L	60	288	180	218	70	40	58	1.50						
68150-66	WDX61 -C40-3D-183L	61	291	183	221	70	40	59	1.40						
68150-67	WDX62 -C40-3D-186L	62	294	186	224	70	40	60	1.30	WDXT186012	T25	M6.0-15.0-9.0-60			
68150-68	WDX63 -C40-3D-189L	63	297	189	227	70	40	61	1.20						
68150-69	WDX64 -C40-3D-192L	64	300	192	230	70	40	62	1.00						
68150-70	WDX65 -C40-3D-195L	65	303	195	233	70	40	63	0.90						
68150-71	WDX66 -C40-3D-198L	66	306	198	236	70	40	64	0.70						
68150-72	WDX67 -C40-3D-201L	67	309	201	239	70	40	65	0.60						
68150-73	WDX68 -C40-3D-204L	68	312	204	242	70	40	65	0.50						
68150-74	WDX14.5-C25-3D-43.5L	14.5	122	43.5	66	56	25	32	0.20				WDXT042004	T6	M1.8-3.0-2.4-60
68150-75	WDX24.5-C32-3D-73.5L	24.5	156	73.5	96	60	32	38.5	0.50				WDXT073506	T8	M2.5-6.0-3.5-60

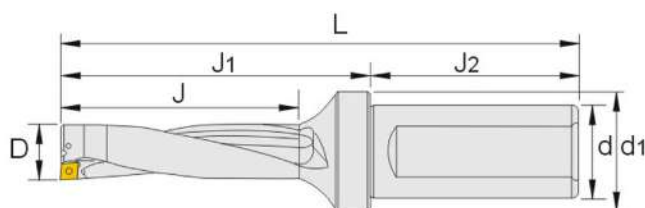
68160**WDX-4D****捨棄式快速鑽頭(4倍長) Rapid Drill (4D)**

90° 單位:mm

訂購編號 Order No.	型號 Model	刃徑 D	全長 L	刃長 J	刃長1 J1	柄長 J2	柄徑 d	外徑 d1	最大 偏移量	刀片類型 Inserts	扳手 Wrench	螺絲 Screw
68160-01	WDX13 -C25-4D-52L	13	132	52	76	56	25		0.35	WDX13	T6	M1.6-2.7-2.4-60
68160-02	WDX13.5-C25-4D-56L	13.5	132	54	76	56	25		0.30			
68160-03	WDX14 -C25-4D-56L	14	136	56	80	56	25		0.25			
68160-04	WDX14.5-C25-4D-60L	14.5	136	58	80	56	25		0.20			
68160-05	WDX15 -C25-4D-60L	15	140	60	84	56	25		0.15			
68160-06	WDX15.5-C25-4D-64L	15.5	140	62	84	56	25		0.40	WDX15.5	T6	M2.0-5.0-2.7-60
68160-07	WDX16 -C25-4D-64L	16	144	64	88	56	25		0.40			
68160-08	WDX16.5-C25-4D-68L	16.5	144	66	88	56	25		0.35			
68160-09	WDX17 -C25-4D-68L	17	148	68	92	56	25		0.30			
68160-10	WDX17.5-C25-4D-72L	17.5	148	70	92	56	25		0.25			
68160-11	WDX18 -C25-4D-72L	18	152	72	96	56	25		0.20	WDX18	T7	M2.2-5.5-3.4-60
68160-12	WDX18.5-C25-4D-76L	18.5	152	74	96	56	25	32	0.50			
68160-13	WDX19 -C25-4D-76L	19	156	76	100	56	25		0.45			
68160-14	WDX19.5-C25-4D-80L	19.5	156	78	100	56	25		0.40			
68160-15	WDX20 -C25-4D-80L	20	160	80	104	56	25		0.30			
68160-16	WDX20.5-C25-4D-84L	20.5	160	82	104	56	25		0.30	WDX20.5	T8	M2.5-6.0-3.5-60
68160-17	WDX21 -C25-4D-84L	21	164	84	108	56	25		0.20			
68160-18	WDX21.5-C25-4D-88L	21.5	164	86	108	56	25		0.15			
68160-19	WDX22 -C25-4D-88L	22	168	88	112	56	25		0.10			
68160-20	WDX22.5-C25-4D-92L	22.5	168	90	112	56	25		0.05			
68160-21	WDX23 -C25-4D-92L	23	172	92	116	56	25		0.70	WDX23	T8	M2.5-6.0-3.5-60
68160-22	WDX23.5-C32-4D-96L	23.5	176	94	116	60	32		0.70			
68160-23	WDX24 -C32-4D-96L	24	180	96	120	60	32		0.60			
68160-24	WDX24.5-C32-4D-100L	24.5	180	98	120	60	32		0.50			
68160-25	WDX25 -C32-4D-100L	25	184	100	124	60	32		0.50			
68160-26	WDX25.5-C32-4D-104L	25.5	184	102	124	60	32	38.5	0.45			
68160-27	WDX26 -C32-4D-104L	26	193	104	133	60	32		0.40			
68160-28	WDX26.5-C32-4D-108L	26.5	193	106	133	60	32		0.35			
68160-29	WDX27 -C32-4D-108L	27	197	108	137	60	32		0.25			
68160-30	WDX27.5-C32-4D-112L	27.5	197	110	137	60	32		0.20			
68160-31	WDX28 -C32-4D-112L	28	201	112	141	60	32		0.15			
68160-32	WDX28.5-C32-4D-116L	28.5	201	114	141	60	32		0.10			

切削工具
CUTTING TOOL

68160
WDX-4D
捨棄式快速鑽頭(4倍長) Rapid Drill (4D)

單位:mm

訂購編號 Order No.	型號 Model	刃徑 D	全長 L	刃長 J	刃長1 J1	柄長 J2	柄徑 d	外徑 d1	最大 偏移量	刀片類型 Inserts	扳手 Wrench	螺絲 Screw	
68160-33	WDX29 -C32-4D-116L	29	205	116	145	60	32	38.5	1.00	WDXT094008	T15	M3.5-8.0-5.3-60	
68160-34	WDX29.5-C32-4D-120L	29.5	205	118	149	60	32		0.95				
68160-35	WDX30 -C32-4D-120L	30	209	120	149	60	32		0.90				
68160-36	WDX31 -C32-4D-124L	31	213	124	153	60	32		0.80				
68160-37	WDX32 -C32-4D-128L	32	217	128	157	60	32		0.70				
68160-38	WDX33 -C32-4D-132L	33	221	132	161	60	32		0.55				
68160-39	WDX34 -C32-4D-136L	34	225	136	165	60	32		0.45				
68160-40	WDX35 -C32-4D-140L	35	229	140	169	60	32		0.35				
68160-41	WDX36 -C32-4D-144L	36	233	144	173	60	32		0.20				
68160-42	WDX37 -C32-4D-148L	37	237	148	177	60	32		1.00				
68160-43	WDX38 -C32-4D-152L	38	241	152	181	60	32	1.00					
68160-44	WDX39 -C32-4D-156L	39	245	156	185	60	32	0.90					
68160-45	WDX40 -C40-4D-160L	40	259	160	189	70	40	48	0.80	WDXT125012	T20	M5.0-11.0-7.0-60	
68160-46	WDX41 -C40-4D-164L	41	263	164	193	70	40		0.70				
68160-47	WDX42 -C40-4D-168L	42	267	168	197	70	40		0.60				
68160-48	WDX43 -C40-4D-172L	43	271	172	201	70	40		0.50				
68160-49	WDX44 -C40-4D-176L	44	275	176	205	70	40		0.50				
68160-50	WDX45 -C40-4D-180L	45	279	180	209	70	40		0.40				
68160-51	WDX46 -C40-4D-184L	46	289	184	219	70	40		1.50				
68160-52	WDX47 -C40-4D-188L	47	293	188	223	70	40		1.40				
68160-53	WDX48 -C40-4D-192L	48	297	192	227	70	40		1.30				
68160-54	WDX49 -C40-4D-196L	49	301	196	231	70	40		1.20				
68160-55	WDX50 -C40-4D-200L	50	305	200	235	70	40	54	1.10	WDXT156012	T25	M6.0-15.0-9.0-60	
68160-56	WDX51 -C40-4D-204L	51	309	204	239	70	40		1.00				
68160-57	WDX52 -C40-4D-208L	52	313	208	243	70	40		0.90				
68160-58	WDX53 -C40-4D-212L	53	317	212	247	70	40		0.80				
68160-59	WDX54 -C40-4D-216L	54	321	216	251	70	40		0.60				
68160-60	WDX55 -C40-4D-220L	55	325	220	255	70	40		0.50				
68160-61	WDX56 -C40-4D-224L	56	332	224	262	70	40		2.00				
68160-62	WDX57 -C40-4D-228L	57	336	228	266	70	40		55				1.80
68160-63	WDX58 -C40-4D-232L	58	340	232	270	70	40		56				1.70
68160-64	WDX59 -C40-4D-236L	59	344	236	274	70	40		57				1.60
68160-65	WDX60 -C40-4D-240L	60	348	240	278	70	40	58	1.50				
68160-66	WDX61 -C40-4D-244L	61	352	244	282	70	40	59	1.40				
68160-67	WDX62 -C40-4D-248L	62	356	248	288	70	40	60	1.30	WDXT186012	T25	M6.0-15.0-9.0-60	
68160-68	WDX63 -C40-4D-252L	63	360	252	290	70	40	61	1.20				
68160-69	WDX64 -C40-4D-256L	64	364	256	294	70	40	62	1.00				
68160-70	WDX65 -C40-4D-260L	65	368	260	298	70	40	63	0.90				
68160-71	WDX66 -C40-4D-264L	66	372	264	302	70	40	64	0.70				
68160-72	WDX67 -C40-4D-268L	67	376	268	306	70	40	65	0.60				
68160-73	WDX68 -C40-4D-272L	68	380	272	310	70	40	66	0.50				



 切削工具
CUTTING TOOL

切削工具 Cutting Tool

68170

WDX-5D

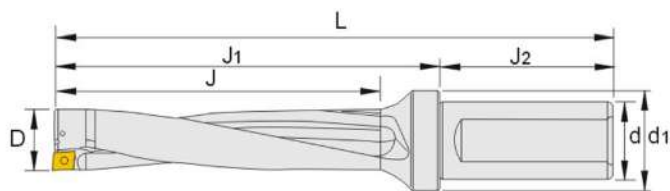
捨棄式快速鑽頭(5倍長) Rapid Drill (5D)



90° 單位:mm

訂購編號 Order No.	型號 Model	刃徑 D	全長 L	刃長 J	刃長1 J1	刃長2 J2	柄徑 d	外徑 d1	最大 偏移量	刀片類型 Inserts	扳手 Wrench	螺絲 Screw
68170-01	WDX17 -C25-5D-85L	17	159	85	109	56	25	32	0.30	WDX052504	T6	M2.0-5.0-2.7-60
68170-02	WDX17.5-C25-5D-90L	17.5	159	87.5	109	56	25		0.25			
68170-03	WDX18 -C25-5D-90L	18	164	90	114	56	25		0.20			
68170-04	WDX18.5-C25-5D-95L	18.5	170	92.5	114	56	25		0.50			
68170-05	WDX19 -C25-5D-95L	19	175	95	119	56	25		0.45			
68170-06	WDX19.5-C25-5D-100L	19.5	175	97.5	119	56	25		0.40			
68170-07	WDX20 -C25-5D-100L	20	180	100	124	56	25		0.30	WDX063006	T7	M2.2-5.5-3.4-60
68170-08	WDX20.5-C25-5D-105L	20.5	180	102.5	124	56	25		0.30			
68170-09	WDX21 -C25-5D-105L	21	185	105	129	56	25		0.20			
68170-10	WDX21.5-C25-5D-110L	21.5	185	107.5	129	56	25		0.15			
68170-11	WDX22 -C25-5D-110L	22	190	110	134	56	25		0.10			
68170-12	WDX22.5-C25-5D-115L	22.5	190	112.5	134	56	25		0.05			
68170-13	WDX23 -C25-5D-115L	23	195	115	139	56	25	0.70	WDX073506	T8	M2.5-6.0-3.5-60	
68170-14	WDX23.5-C32-5D-120L	23.5	195	117.5	135	60	32	0.70				
68170-15	WDX24 -C32-5D-120L	24	204	120	144	60	32	0.60				
68170-16	WDX24.5-C32-5D-125L	24.5	204	122.5	144	60	32	0.50				
68170-17	WDX25 -C32-5D-125L	25	209	125	149	60	32	0.50				
68170-18	WDX25.5-C32-5D-130L	25.5	209	127.5	149	60	32	0.45				
68170-19	WDX26 -C32-5D-130L	26	219	130	159	60	32	0.40				
68170-20	WDX26.5-C32-5D-135L	26.5	219	132.5	159	60	32	0.35				
68170-21	WDX27 -C32-5D-135L	27	224	135	164	60	32	0.25				
68170-22	WDX27.5-C32-5D-140L	27.5	224	137.5	164	60	32	0.20				
68170-23	WDX28 -C32-5D-140L	28	229	140	169	60	32	0.15				
68170-24	WDX28.5-C32-5D-145L	28.5	229	142.5	169	60	32	0.10				38.5
68170-25	WDX29 -C32-5D-145L	29	234	145	174	60	32	1.00				
68170-26	WDX29.5-C32-5D-150L	29.5	234	147.5	174	60	32	0.95				
68170-27	WDX30 -C32-5D-150L	30	239	150	179	60	32	0.90				
68170-28	WDX31 -C32-5D-155L	31	244	155	184	60	32	0.80				
68170-29	WDX32 -C32-5D-160L	32	249	160	189	60	32	0.70				
68170-30	WDX33 -C32-5D-165L	33	254	165	194	60	32	0.55				
68170-31	WDX34 -C32-5D-170L	34	259	170	199	60	32	0.45				
68170-32	WDX35 -C32-5D-175L	35	264	175	204	60	32	0.35				
68170-33	WDX36 -C32-5D-180L	36	269	180	209	60	32	0.20				

切削工具
CUTTING TOOL

68170
WDX-5D
捨棄式快速鑽頭(5倍長) Rapid Drill (5D)

單位:mm

訂購編號 Order No.	型號 Model	刃徑 D	全長 L	刃長 J	刃長1 J1	柄長 J2	柄徑 d	外徑 d1	最大 偏移量	刀片類型 Inserts	扳手 Wrench	螺絲 Screw			
68170-34	WDX37 -C32-5D-185L	37	274	185	214	60	32	38.5	1.00	WDXT125012	T20	M5-11-7.0-60			
68170-35	WDX38 -C32-5D-190L	38	279	190	219	60	32		1.00						
68170-36	WDX39 -C32-5D-195L	39	284	195	224	60	32		0.90						
68170-37	WDX40 -C40-5D-200L	40	299	200	229	70	40	48	0.80						
68170-38	WDX41 -C40-5D-205L	41	304	205	234	70	40		0.70						
68170-39	WDX42 -C40-5D-210L	42	309	210	239	70	40		0.60						
68170-40	WDX43 -C40-5D-215L	43	314	215	244	70	40		0.50						
68170-41	WDX44 -C40-5D-220L	44	319	220	249	70	40		0.50						
68170-42	WDX45 -C40-5D-225L	45	324	225	254	70	40		0.40						
68170-43	WDX46 -C40-5D-230L	46	335	230	265	70	40		1.50						
68170-44	WDX47 -C40-5D-235L	47	340	235	270	70	40		1.40						
68170-45	WDX48 -C40-5D-240L	48	345	240	275	70	40		1.30						
68170-46	WDX49 -C40-5D-245L	49	350	245	280	70	40		1.20						
68170-47	WDX50 -C40-5D-250L	50	355	250	285	70	40	54	1.10				WDXT156012	T25	M6-15-9.0-60
68170-48	WDX51 -C40-5D-255L	51	360	255	290	70	40		1.00						
68170-49	WDX52 -C40-5D-260L	52	365	260	295	70	40		0.90						
68170-50	WDX53 -C40-5D-265L	53	370	265	300	70	40		0.80						
68170-51	WDX54 -C40-5D-270L	54	375	270	305	70	40		0.60						
68170-52	WDX55 -C40-5D-275L	55	380	275	310	70	40		0.50						

 切削工具
CUTTING TOOL

切削工具 Cutting Tool

WDX快速鑽頭切削數據

加工材質	HB	HR.C	推薦刀片	切削速度 (Vc)m/min	進給量(f)mm/rev				
					∅13.0~∅18.0	∅18.5~∅29.0	∅29.5~∅36.0	∅37.0~∅55.0	
P	鋼,碳素鋼 SS400	125	(14)	G型ACP300	100-150-200	0.05-0.07-0.10	0.05-0.07-0.10	0.05-0.08-0.11	0.05-0.08-0.12
	鋼,碳素鋼 S15C	125	24	L型ACP300	130-170-220	0.04-0.07-0.10	0.04-0.07-0.10	0.04-0.08-0.11	0.05-0.09-0.12
	鋼,碳素鋼 S45C	190	27	G型ACP300	100-150-200	0.08-0.12-0.20	0.08-0.12-0.20	0.08-0.13-0.22	0.09-0.14-0.24
	鋼,碳素鋼 S45C淬火	250	31	G型ACP300	80-120-160	0.06-0.10-0.15	0.06-0.10-0.15	0.06-0.11-0.16	0.07-0.12-0.18
	鋼,碳素鋼 S75C	270		G型ACP300	100-130-160	0.08-0.12-0.18	0.08-0.12-0.18	0.08-0.13-0.19	0.09-0.14-0.22
	鋼,碳素鋼 S75C淬火	300		G型ACP300	70-100-140	0.06-0.10-0.14	0.06-0.10-0.14	0.06-0.11-0.15	0.07-0.12-0.17
	低合金鋼 SCM,SNCM	180		L型ACP300	100-140-180	0.05-0.07-0.12	0.05-0.07-0.12	0.05-0.08-0.13	0.06-0.08-0.15
	SCM,SNCM淬火	275	28	G型ACP300	80-120-160	0.06-0.10-0.14	0.06-0.10-0.14	0.06-0.11-0.15	0.07-0.12-0.17
	SCM,SNCM淬火	300	31	G型ACP300	75-110-140	0.06-0.10-0.14	0.06-0.10-0.14	0.06-0.11-0.15	0.07-0.12-0.17
	SCM,SNCM淬火	350	37	G型ACP300	60-85-110	0.06-0.10-0.14	0.06-0.10-0.14	0.06-0.11-0.15	0.07-0.12-0.17
高合金鋼 SKD,SKT,SKH	200	(14)	G型ACP300	100-130-160	0.08-0.12-0.20	0.08-0.12-0.20	0.08-0.13-0.22	0.09-0.14-0.24	
SKD,SKT,SKH淬火	325	34	G型ACP300	80-100-120	0.06-0.10-0.15	0.06-0.10-0.15	0.06-0.11-0.16	0.07-0.12-0.18	
M	不銹鋼SUS403(馬氏體/鐵素體)	200	(14)	G型ACP300	100-140-180	0.06-0.10-0.15	0.06-0.10-0.15	0.06-0.11-0.16	0.07-0.12-0.18
	不銹鋼SUS403(馬氏體/淬火)	240	22	G型ACP300	90-120-150	0.06-0.10-0.15	0.06-0.10-0.15	0.06-0.11-0.16	0.07-0.12-0.18
	不銹鋼SUS304,SUS316(奧氏體)	180		G型ACP300	100-140-180	0.06-0.10-0.15	0.06-0.10-0.15	0.06-0.11-0.16	0.07-0.12-0.18
K	鑄鐵			H型ACK300	120-160-200	0.09-0.18-0.27	0.10-0.20-0.30	0.11-0.22-0.32	0.12-0.24-0.36
	球墨鑄鐵			H型ACK300	90-120-150	0.09-0.18-0.27	0.10-0.20-0.30	0.11-0.22-0.32	0.12-0.24-0.36
S	難削材(耐熱合金,超合金,Ti合金etc.)	200	(14)	G型ACP300	25-50-70	0.06-0.10-0.15	0.06-0.10-0.15	0.06-0.11-0.16	0.07-0.12-0.18
N	鋁合金			G型DL1500	200-260-320	0.06-0.11-0.17	0.06-0.11-0.17	0.06-0.12-0.18	0.07-0.13-0.20
	銅合金			G型DL1500	180-230-280	0.06-0.11-0.17	0.06-0.11-0.17	0.06-0.12-0.18	0.07-0.13-0.20

- 1.主軸轉數(S)=(1000x切削速度(Vc))/(πX刀具外徑) 工作臺進給量(F)=主軸轉速(S)X刀具刃數(T)進給量(f)。
- 2.本表系以刀具外徑之三倍長為參考值,實際切削數據需考量機臺條件做相關調整。
- 3.4倍長以上進給量減15%。
- 4.無中心出水進給量減10%。

68180

HWAS

偏心套筒 Eccentric Sleeve

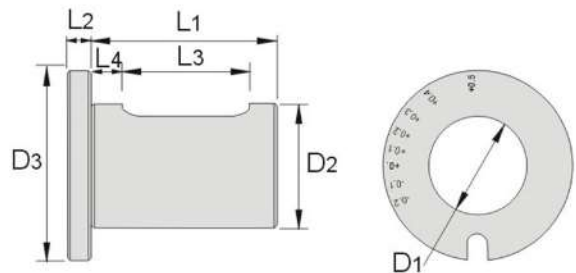

訂購編號 Order No.	型號 Model	D1	D2	D3	L1	L2	L3	L4	扳手
68180-01	HWAS2532	25	32	42	60	7	46	6	+0.3~-0.3
68180-02	HWAS3240	32	40	55	70	7	57	6	+0.3~-0.3

- 1.偏心套筒之刻度僅供參考,調整后,請測量實際加工直徑進行調整。
- 2.請使用側固刀杆,一般筒夾、套筒或彈簧夾頭刀杆不可使用。
- 3.此調整範圍表示的是以直徑調整範圍。

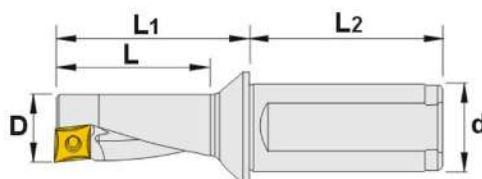

68190
HCAP
車削快速鑽頭 Turning Fast Drill

HCAP車削快速鑽頭-2.25D

單位:mm

訂購編號 Order No.	型號 Model	刀徑 D	柄徑 d	刃長 L	刀長1 L1	刀長2 L2	刀片類型 Inserts	扳手 Wrench
68190-01	HCAP-08R-C12-2.25D-18L	8	12	18	24	42	XCM(N)T 0401	T6
68190-02	HCAP-10R-C12-2.25D-22.5L	10	12	22.5	29	42	XCM(N)T 0502	T6
68190-03	HCAP-12R-C16-2.25D-27L	12	16	27	35	45	XCM(N)T 0602	T7
68190-04	HCAP-14R-C16-2.25D-31.5L	14	16	31.5	40	45	XCM(N)T 0703	T8
68190-05	HCAP-16R-C20-2.25D-36L	16	20	36	45	50	XCM(N)T 0803	T9
68190-06	HCAP-20R-C25-2.25D-45L	20	25	45	56	56	XCM(N)T 10T3	T15

HCAP車削快速鑽頭-3D

單位:mm

訂購編號 Order No.	型號 Model	刀徑 D	柄徑 d	刃長 L	刀長1 L1	刀長2 L2	刀片類型 Inserts	扳手 Wrench
68200-01	HCAP-08R-C12-3D-24L	8	12	24	30	42	XCM(N)T 0401	T6
68200-02	HCAP-10R-C12-3D-30L	10	12	30	36.5	42	XCM(N)T 0502	T6
68200-03	HCAP-12R-C16-3D-36L	12	16	36	44	45	XCM(N)T 0602	T7
68200-04	HCAP-14R-C16-3D-42L	14	16	42	50.5	45	XCM(N)T 0703	T8
68200-05	HCAP-16R-C20-3D-48L	16	20	48	57	50	XCM(N)T 0803	T9
68200-06	HCAP-20R-C25-3D-60L	20	25	60	51	56	XCM(N)T 10T3	T15

1. 單一刀具, 即可車削內外徑、鑽孔, 減少刀具更換, 提升加工效率。
2. 螺旋狀以及大派屑槽, 大大增加排屑效果。

HCAP切削數據表

單位:mm

被切削材	硬度	鑽孔轉速	車削轉速
P	低碳鋼	~150	130~240
	碳素鋼	150~250	90~160
	低合金鋼	~180	120~210
	中合金鋼	200~250	70~140
	高合金鋼	250~350	50~100
M	不銹鋼(馬氏體)	200	110~180
	不銹鋼(奧氏體)	200	90~160
K	灰鑄鐵	180~220	110~180
	球墨鑄鐵	200~240	90~160
N	鋁合金	60~130	100~500
	銅合金	90~100	100~400

刀片	加工方式	每刃切深	每刃進給
XCMT040104	車削	0.6(0.2~1.8)	0.05(0.02~0.15)
	鑽孔	-	0.06(0.02~0.09)
XCMT050204	車削	0.8(0.2~2.2)	0.08(0.03~0.18)
	鑽孔	-	0.06(0.02~0.11)
XCMT060204	車削	1.0(0.3~2.5)	0.08(0.03~0.20)
	鑽孔	-	0.08(0.03~0.12)
XCMT070304	車削	1.2(0.4~2.8)	0.12(0.05~0.22)
	鑽孔	-	0.08(0.03~0.13)
XCMT080304	車削	1.5(0.4~3.2)	0.12(0.06~0.25)
	鑽孔	-	0.08(0.03~0.13)
XCMT10T304	車削	1.8(0.5~3.5)	0.12(0.06~0.30)
	鑽孔	-	0.08(0.03~0.13)



 切削工具
CUTTING TOOL

切削工具 Cutting Tool

68210

HD-3D

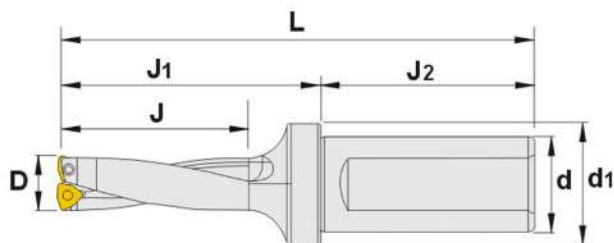
捨棄式快速鑽頭(3倍長) Rapid Drill (3D)



單位:mm

訂購編號 Order No.	型號 Model	刃徑 D	全長 L	刀長 J	刀長1 J1	刀長2 J2	柄徑 d	外徑 d1	刀片類型 Inserts	扳手 Wrench	螺絲 Screw
68210-01	HD15-C25-3D-45L	15	118	45	62	56	25	32	WC□□0302	T8	M2.5-6.0-3.5-60
68210-02	HD16-C25-3D-48L	16	121	48	65	56	25				
68210-03	HD17-C25-3D-51L	17	124	51	68	56	25				
68210-04	HD18-C25-3D-54L	18	127	54	71	56	25				
68210-05	HD19-C25-3D-57L	19	130	57	74	56	25				
68210-06	HD20-C25-3D-60L	20	133	60	77	56	25		WC□□0402	T8	M2.5-6.0-3.5-60
68210-07	HD21-C25-3D-63L	21	136	63	80	56	25				
68210-08	HD22-C25-3D-66L	22	139	66	83	56	25				
68210-09	HD23-C25-3D-69L	23	142	69	86	56	25				
68210-10	HD24-C32-3D-72L	24	146	72	86	60	32				
68210-11	HD25-C32-3D-75L	25	150	75	90	60	32				
68210-12	HD26-C32-3D-78L	26	154	78	94	60	32				
68210-13	HD27-C32-3D-81L	27	158	81	98	60	32				
68210-14	HD28-C32-3D-84L	28	162	84	102	60	32				
68210-15	HD29-C32-3D-87L	29	166	87	106	60	32				
68210-16	HD30-C32-3D-90L	30	170	90	110	60	32				
68210-17	HD31-C32-3D-93L	31	174	93	114	60	32				
68210-18	HD32-C32-3D-96L	32	178	96	118	60	32				
68210-19	HD33-C32-3D-99L	33	182	99	122	60	32	WC□□06T3	T15	M3.5-8.0-5.3-60	
68210-20	HD34-C32-3D-102L	34	186	102	126	60	32				
68210-21	HD35-C32-3D-105L	35	190	105	130	60	32				
68210-22	HD36-C32-3D-108L	36	194	108	134	60	32				
68210-23	HD37-C32-3D-111L	37	198	111	138	60	32				
68210-24	HD38-C32-3D-114L	38	202	114	142	60	32				
68210-25	HD39-C32-3D-117L	39	206	117	146	60	32				
68210-26	HD40-C40-3D-120L	40	216	120	146	70	40				
68210-27	HD41-C40-3D-123L	41	220	123	150	70	40				

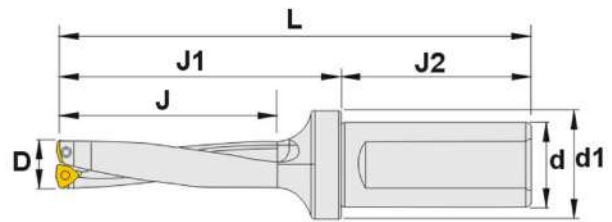

切削工具
CUTTING TOOL

68220
HD-4D
捨棄式快速鑽頭(4倍長) Rapid Drill (4D)

單位:mm

訂購編號 Order No.	型號 Model	刃徑 D	全長 L	刃長 J	刃長1 J1	柄長 J2	柄徑 d	外徑 d1	刀片類型 Inserts	扳手 Wrench	螺絲 Screw				
68220-01	HD15-C25-4D-60L	15	140	60	83	56	25	32	WC□□0302	T8	M2.5-6.0-3.5-60				
68220-02	HD16-C25-4D-64L	16	144	64	87	56	25								
68220-03	HD17-C25-4D-68L	17	148	68	91	56	25								
68220-04	HD18-C25-4D-72L	18	152	72	95	56	25								
68220-05	HD19-C25-4D-76L	19	156	76	99	56	25								
68220-06	HD20-C25-4D-80L	20	160	80	103	56	25								
68220-07	HD21-C25-4D-84L	21	164	84	107	56	25								
68220-08	HD22-C25-4D-88L	22	168	88	111	56	25								
68220-09	HD23-C25-4D-92L	23	172	92	115	56	25								
68220-10	HD24-C32-4D-96L	24	185	96	119	60	32								
68220-11	HD25-C32-4D-100L	25	189	100	123	60	32	38.5	WC□□0402	T8	M2.5-6.0-3.5-60				
68220-12	HD26-C32-4D-104L	26	193	104	127	60	32								
68220-13	HD27-C32-4D-108L	27	197	108	131	60	32								
68220-14	HD28-C32-4D-112L	28	201	112	135	60	32								
68220-15	HD29-C32-4D-116L	29	205	116	139	60	32								
68220-16	HD30-C32-4D-120L	30	209	120	143	60	32								
68220-17	HD31-C32-4D-124L	31	213	124	147	60	32								
68220-18	HD32-C32-4D-128L	32	217	128	151	60	32								
68220-19	HD33-C32-4D-132L	33	221	132	155	60	32								
68220-20	HD34-C32-4D-136L	34	225	136	159	60	32								
68220-21	HD35-C32-4D-140L	35	229	140	163	60	32	38.5	WC□□0503	T9	M3.5-8.0-4.4-60				
68220-22	HD36-C32-4D-144L	36	233	144	167	60	32								
68220-23	HD37-C32-4D-148L	37	237	148	171	60	32								
68220-24	HD38-C32-4D-152L	38	241	152	175	60	32								
68220-25	HD39-C32-4D-156L	39	245	156	185	60	32								
68220-26	HD40-C40-4D-160L	40	260	160	190	70	40								
68220-27	HD41-C40-4D-164L	41	264	164	194	70	40								
												48.5	WC□□06T3	T15	M3.5-8.0-5.3-60



 切削工具
CUTTING TOOL

切削工具 Cutting Tool

68230

SRB

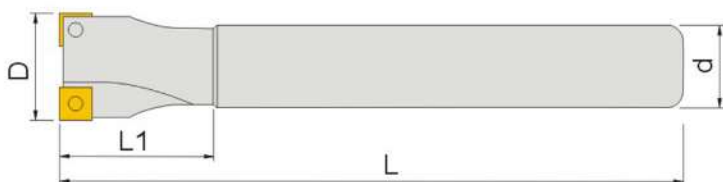
高速粗搪刀 High Speed Rough Boring Cutter



切削範例:

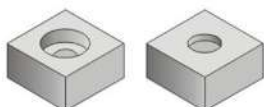

單位:mm

訂購編號 Order No.	型號 Model	D	d	L1	L	T	刀片類型 Inserts	螺絲 Screw	扳手 Wrench
68230-1210	SRB 1210R-2T	11.8	10	20	100	2	SPMG 050204	TS2003	TK06
68230-1312	SRB 1312R-2T	12.8	12	20	100				
68230-1412	SRB 1412R-2T	13.8	12	25	100				
68230-1512	SRB 1512R-2T	14.8	12	25	100				
68230-1612	SRB 1612R-2T	15.8	12	30	100		SPMG 060204	TS2205	TK06
68230-1816	SRB 1816R-2T	17.7	16	30	130				
68230-2016	SRB 2016R-2T	19.7	16	30	130				
68230-2216	SRB 2216R-2T	21.7	16	30	130				
68230-2420	SRB 2420R-2T	23.7	20	30	150		SPMG 090408	TS3504	TK15
68230-2520	SRB 2520R-2T	24.7	20	30	150				
68230-2620	SRB 2620R-2T	25.7	20	30	150				
68230-2720	SRB 2720R-2T	26.7	20	30	150				
68230-2820	SRB 2820R-2T	27.7	20	30	150		SPMG 110408	TS4006	TK15
68230-3025	SRB 3025R-2T	29.7	25	40	200				
68230-3225	SRB 3225R-2T	31.7	25	40	200				
68230-3525	SRB 3525R-2T	34.7	25	40	200				
68230-3625	SRB 3625R-2T	35.7	25	40	200		SPMG 110408	TS4006	TK15
68230-4025	SRB 4025R-2T	39.7	25	40	200				
68230-4232	SRB 4232R-2T	41.7	32	45	200				
68230-4532	SRB 4532R-2T	44.7	32	45	200				
68230-4832	SRB 4832R-2T	47.7	32	45	200	SPMG 110408	TS4006	TK15	
68230-5032	SRB 5032R-2T	49.7	32	45	200				

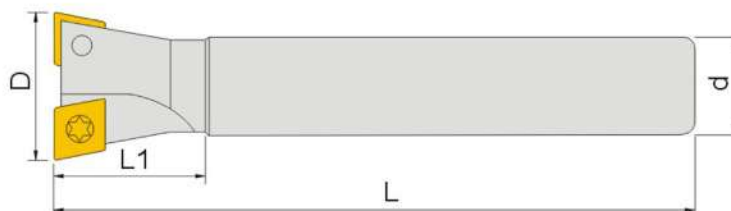

切削工具
CUTTING TOOL

68240
FRB
定值粗搪刀 Rough Boring Cutter

切削範例:

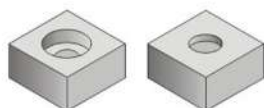

單位:mm

訂購編號 Order No.	型號 Model	D	d	L1	L	刀片類型 Inserts	螺絲 Screw	扳手 Wrench
68240-1412	FRB 1412R-1T	13.8	12	25	100	CCMT 060204	TS2515	TK08
68240-1612	FRB 1612R-2T	15.8	12	30	100			
68240-1816	FRB 1816R-2T	17.7	16	30	120			
68240-1916	FRB 1916R-2T	18.7	16	30	120			
68240-2016	FRB 2016R-2T	19.7	16	30	120			
68240-2216	FRB 2216R-2T	21.7	16	30	120			
68240-2420	FRB 2420R-2T	23.7	20	30	130			
68240-2520	FRB 2520R-2T	24.7	20	30	130			
68240-2620	FRB 2620R-2T	25.7	20	30	130	CCMT 09T304	TS4004	TK15
68240-2720	FRB 2720R-2T	26.7	20	30	130			
68240-2820	FRB 2820R-2T	27.7	20	30	130			
68240-3025	FRB 3025R-2T	29.7	25	40	160			
68240-3225	FRB 3225R-2T	31.7	25	40	160			
68240-3525	FRB 3525R-2T	34.7	25	40	160			
68240-3625	FRB 3625R-2T	35.7	25	40	160			
68240-4025	FRB 4025R-2T	39.7	25	40	160			
68240-4232	FRB 4232R-2T	41.7	32	45	200			
68240-4532	FRB 4532R-2T	44.7	32	45	200			
68240-4832	FRB 4832R-2T	47.7	32	45	200			
68240-5032	FRB 5032R-2T	49.7	32	45	200			
68240-5232	FRB 5232R-2T	51.7	32	45	200			
68240-5532	FRB 5532R-2T	54.7	32	45	200			



 切削工具
CUTTING TOOL

切削工具 Cutting Tool

68250

HSP

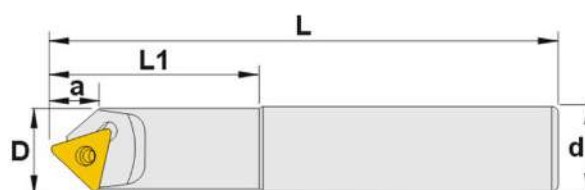
倒角刀 Chamferring End Mill



HSP45度定位倒角刀

45°

單位:mm

訂購編號 Order No.	型號 Model	刃徑 D	全長 L	刃長 L1	柄徑 d	a	倒角範圍	刀片類型 Inserts	扳手 Wrench	螺絲 Screw
68250-01	HSP45-1212-105	12	105	26	12	8	∅0~∅6	TC□□1003	T8	M2.5-6.0-3.5-60
68250-02	HSP45-2012-100	20	100	22	12	11.3	∅0~∅20	TC□□16T3	T15	M4.0-10-5.0-43
68250-03	HSP45-2020-120	20	120	50	20	11.3	∅0~∅20			

HSP60度倒角刀

60°

單位:mm

訂購編號 Order No.	型號 Model	刃徑 D	全長 L	刃長 L1	柄徑 d	a	刀片類型 Inserts	扳手 Wrench	螺絲 Screw
68260-01	HSP60-1212-105L	13.8	105	26	12	8.5	TC□□1003	T8	M2.5-6.0-3.5-60
68260-02	HSP60-1616-110L	19.2	110	30	16	11.16	TC□□13T3	T15	M3.5-8.0-5.0-43
68260-03	HSP60-2020-130L	22.5	130	50	20	11.83	TC□□16T3		M4.0-10-5.0-43

HSP30度倒角刀

30°

單位:mm

訂購編號 Order No.	型號 Model	刃徑 D	全長 L	刃長 L1	柄徑 d	a	刀片類型 Inserts	扳手 Wrench	螺絲 Screw
68270-01	HSP30-1212-105L	13.8	105	26	12	8.5	TC□□1003	T8	M2.5-6.0-3.5-60
68270-02	HSP30-1616-110L	19.2	110	30	16	11.16	TC□□13T3	T15	M3.5-8.0-5.0-43
68270-03	HSP30-2020-130L	22.5	130	50	20	11.83	TC□□16T3		M4.0-10-5.0-43

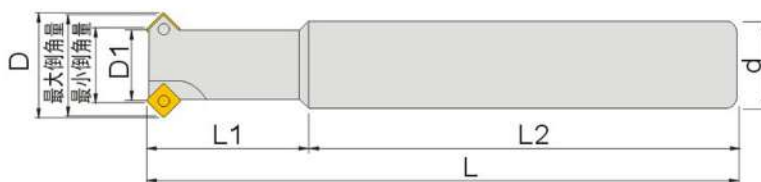
68280
HSC45°
45度内外倒角刀 45° Inner/Outer Chamfering End Mills

45°

單位:mm

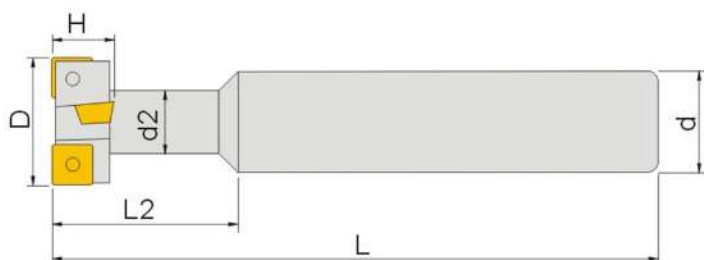
訂購編號 Order No.	型號 Model	刀徑 D	最大 倒角量	最小 倒角量	最小 刀徑	柄徑 d	全長 L	刀長1 L1	刀長2 L2	刀片類型 Inserts	扳手 Wrench	螺絲 Screw
68280-01	HSC-1510-C12-2T	15.7	15	10	8.9	12	120	20	100	SPMG050204	T6	M2.0-5.0-2.7-60
68280-02	HSC-1914-C16-3T	19.7	19	14	12.9	16	150	30	120			
68280-03	HSC-2318-C20-4T	23.7	23	18	16.9	20	150	35	115			
68280-04	HSC-2921-C20-3T	29.9	29	21	19.3	20	150	40	110	SPMG07T308	T8	M2.5-6.0-3.5-60
68280-05	HSC-3628-C25-3T	36.9	36	28	26.3	25	150	40	110			
68280-06	HSC-4335-C25-4T	43.9	43	35	33.3	25	150	40	110			
68280-07	HSC-5042-C25-4T	50.9	50	42	40.3	25	150	40	110			

68290
HST
T型槽端銑刀 T-Slot End Mill

單位:mm

訂購編號 Order No.	型號 Model	刀徑 D	刃高 H	頸徑 d2	全長 L	刀長 L2	柄徑 d	刀片類型 Inserts	扳手 Wrench	螺絲 Screw
68290-01	HST-1908-100L-4T	19	8	9.5	100	25	16	SPMG050204	T6	M2.0-5.0-2.7-60
68290-02	HST-2109-100L-4T	21	9	11	100	27	16	SPMG060204	T8	M2.2-5.5-3.4-60
68290-03	HST-2511-100L-4T	25	11	12	100	31	20	SPMG07T308	T8	M2.5-6.0-3.5-60
68290-04	HST-3214-120L-4T	32	14	17	120	40	25	SPMG090408	T10	M3.5-8.0-5.3-60
68290-05	HST-4018-125L-4T	40	18	21	125	50	25	SPMG110408	T15	M4.0-10-5.7-60
68290-06	HST-5022-130L-4T	50	22	27	130	61	32	SPMG140512	T20	M5.0-11-7.0-60



 切削工具
CUTTING TOOL

切削工具 Cutting Tool

68300

TTA

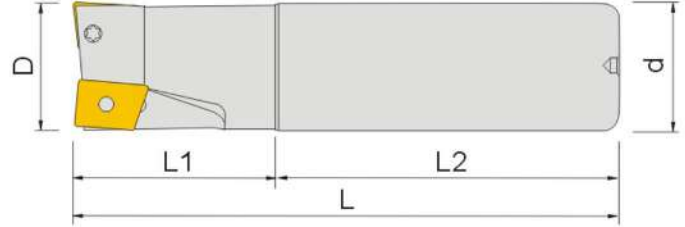
直角高速銑刀 90° Square Shoulder End Mills



單位:mm

訂購編號 Order No.	型號 Model	刀徑 D	柄徑 d	全長 L	刃長1 L1	刃長2 L2	刀具 刃數	刀片類型 Inserts	扳手 Wrench	螺絲 Screw
68300-01	TTA-1010S2-100L	10	10	100	18	82	2	AXMT060204 & AXMT060208	T6	M1.8-3-2.4-60
68300-02	TTA-1010S2-120L	10	10	120	18	102	2			
68300-03	TTA-1110S2-80L	11	10	80	18	62	2			
68300-04	TTA-1110S2-120L	11	10	120	18	102	2			
68300-05	TTA-1212S2-80L	12	12	80	18	62	2			
68300-06	TTA-1212S2-120L	12	12	120	18	102	2			
68300-07	TTA-1212S3-80L	12	12	80	18	62	3			
68300-08	TTA-1212S3-120L	12	12	120	18	102	3			
68300-09	TTA-1312S3-100L	13	12	100	18	82	3			
68300-10	TTA-1312S3-120L	13	12	120	18	102	3			
68300-11	TTA-1412S3-100L	14	12	100	18	82	3			
68300-12	TTA-1412S3-120L	14	12	120	18	102	3			
68300-13	TTA-1516S3-100L	15	16	100	20	80	3			
68300-14	TTA-1516S3-150L	15	16	150	20	130	3			
68300-15	TTA-1616S3-100L	16	16	100	20	80	3			
68300-16	TTA-1616S3-150L	16	16	150	20	130	3			
68300-17	TTA-1716S3-100L	17	16	100	20	80	3			
68300-18	TTA-1716S3-150L	17	16	150	20	130	3			
68300-19	TTA-1816S4-100L	18	16	100	20	80	4			
68300-20	TTA-1816S4-150L	18	16	150	20	130	4			
68300-21	TTA-2020S4-120L	20	20	120	25	95	4			
68300-22	TTA-2020S4-150L	20	20	150	25	125	4			
68300-23	TTA-2120S4-120L	21	20	120	25	95	4			
68300-24	TTA-2120S4-150L	21	20	150	25	125	4			
68300-25	TTA-2220S4-120L	22	20	120	25	95	4			
68300-26	TTA-2220S4-150L	22	20	150	25	125	4			
68300-27	TTA-2525S5-150L	25	25	150	25	125	5			

1. 夾持方式推薦使用側固式刀杆，並將刀柄削出平面處以供側固式刀杆固定。
2. 夾持方式另可使用直筒式強力刀杆，其他方式恕不推薦。
3. TTA非夾持長度最大以刀具全長1/3為限。
4. 如需延長刀身，推薦使用鎖牙式直角高速銑刀。

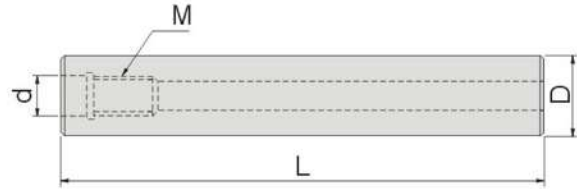

切削工具
CUTTING TOOL

68310
HW
鎢鋼抗震接桿 Tungsten Carbide Connection Rod

單位:mm

訂購編號 Order No.	型號 Model	D	d	L	M
68310-01	HW10-075-M5	10	5.5	75	M5
68310-02	HW10-100-M5	10	5.5	100	M5
68310-03	HW10-150-M5	10	5.5	150	M5
68310-04	HW12-100-M6	12	6.5	100	M6
68310-05	HW12-150-M6	12	6.5	150	M6
68310-06	HW12-200-M6	12	6.5	200	M6
68310-07	HW16-100-M8	16	8.5	100	M8
68310-08	HW16-150-M8	16	8.5	150	M8
68310-09	HW16-200-M8	16	8.5	200	M8
68310-10	HW20-100-M10	20	10.5	100	M10
68310-11	HW20-150-M10	20	10.5	150	M10
68310-12	HW20-200-M10	20	10.5	200	M10
68310-13	HW20-300-M10	20	10.5	300	M10
68310-14	HW25-100-M12	25	12.5	100	M12
68310-15	HW25-150-M12	25	12.5	150	M12
68310-16	HW25-200-M12	25	12.5	200	M12
68310-17	HW25-300-M12	25	12.5	300	M12
68310-18	HW32-150-M16	32	17	150	M16
68310-19	HW32-200-M16	32	17	200	M16
68310-20	HW32-300-M16	32	17	300	M16
68310-21	HW32-400-M16	32	17	400	M16

1. 本延長杆可搭配鎖牙式銑刀加工使用。

 切削工具
CUTTING TOOL

切削工具 Cutting Tool

68320

TTA-SB

鎖牙式直角高速銑刀

Thread type 90° Square Shoulder End Mills

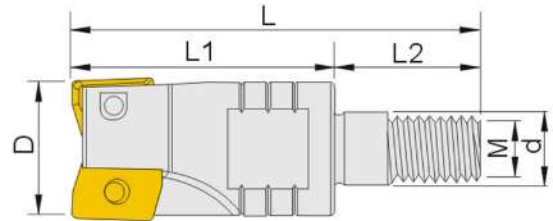

90° 單位:mm

訂購編號 Order No.	型號 Model	刀徑 D	全長 L	刀長1 L1	刀長2 L2	柄徑 d	M	刀具刃數	刀片類型 Inserts	扳手 Wrench	螺絲 Screw
68320-01	TTA-SB1102-M5	11	31	20	11	5.5	M5	2	AXMT060204 & AXMT060208	T6	M1.8-3-2.4-60
68320-02	TTA-SB1303-M6	13	34.5	20.5	14	6.5	M6	3			
68320-03	TTA-SB1703-M8	17	42.5	25.5	17	8.5	M8	3			
68320-04	TTA-SB2104-M10	21	48	30	18	10.5	M10	4			

材質:SKD61

TTA切削數據表-1

單位:mm

被切削材	硬度	每刃切深	轉數	推薦材質	每刃進給	
P	低碳鋼	85-175	1.00~3.00	250~350	TT9030,TT8080	0.04~0.10
	高碳鋼	175-225	1.00~3.00	150~250	TT9030,TT8080	0.04~0.10
	合金鋼	275-325	1.00~3.00	120~220	TT9030,TT8080	0.04~0.10
	工具鋼	200-250	1.00~3.00	90~130	TT8080,TT9030	0.03~0.09
M	不銹鋼(馬氏體)	-	1.00~3.00	120~220	TT8080,TT8020	0.03~0.09
	不銹鋼(奧氏體)	-	1.00~3.00	150~250	TT8080,TT8020	0.03~0.09
S	高硬度合金	-	1.00~2.00	25~40	TT8080,TT8020	0.02~0.07
	鈦合金	-	1.00~2.00	40~50	TT9030,TT8080	0.02~0.07
K	鑄鐵	190-220	1.00~4.00	250~350	TT9030	0.05~0.10
	球墨鑄鐵	140-200	1.00~4.00	140~280	TT9030	0.05~0.08
N	鋁	-	1.00~4.00	350~500	K10	0.05~0.15

TTA切削數據表-2

單位:mm

刀具尺寸	斜向進刀			螺旋下刀		
	最大進刀角度	最大切深量	最小進刀長度	最小螺旋直徑	最大螺旋直徑	最大間距
TTA10	5	5	57	13		0.7
					20	2.3
TTA12	6	5	48	17		1.4
					24	3.4
TTA16	4	5	72	25		1.7
					32	3
TTA25	3	5	95	33		1.8
					40	2.8

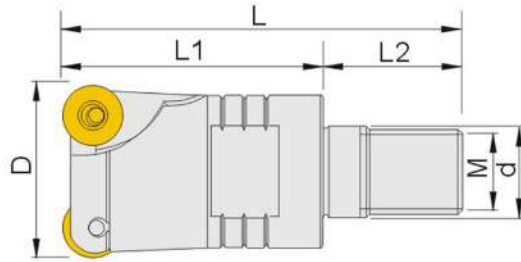
68330
HTR
鎖牙式圓刃高速銑刀 Thread type End Mill

R 單位:mm

訂購編號 Order No.	型號 Model	刀徑 D	全長 L	刀長1 L1	刀長2 L2	柄徑 d	M	刀具刃數	刀片類型 Inserts	扳手 Wrench	螺絲 Screw
68330-01	HTR-2.5R-12-M6	12	39	17	22	6.5	M6	2	RD□□0501	T6	M2.0-3.8-2.68-43
68330-02	HTR-3.5R-16-M8	16	41	18	23	8.5	M8	2	RD□□0702	T8	M3.5-8.0-5.0-43
68330-03	HTR-3.5R-20-M10	20	49	19	30	10.5	M10	2			
68330-04	HTR-3.5R-25-M12	25	58	23	35	12.5	M12	3			

材質:SKD61

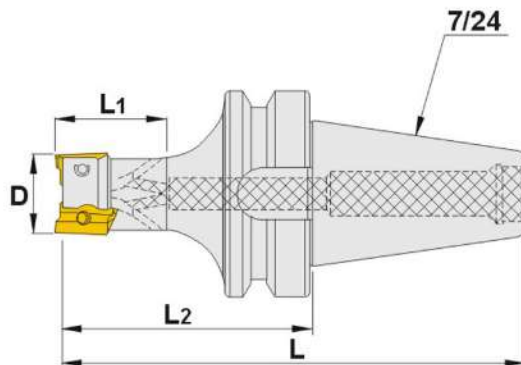
68340
HWEX
鋼體刀桿 Corner Rounding End Mills

單位:mm

訂購編號 Order No.	型號 Model	刀徑 D	刀長1 L1	刀長2 L2	刀長 L	刀具刃數	刀片類型 Inserts	扳手 Wrench	螺絲 Screw
68340-01	BT40-HWEX16A12-2T-C-90	16	40	90	155	2	AXMT123504	T8	M3.0-6.0-3.8-60
68340-02	BT40-HWEX20A12-3T-C-90	20				3			
68340-03	BT40-HWEX25A12-4T-C-90	25				4			
68340-04	BT40-HWEX25A17-2T-C-90	25				AXMT170508	T15	M4.0-9.0-5.6-60	
68340-05	BT40-HWEX32A17-3T-C-90	32							3



 切削工具
CUTTING TOOL

切削工具 Cutting Tool

68350

HWEX

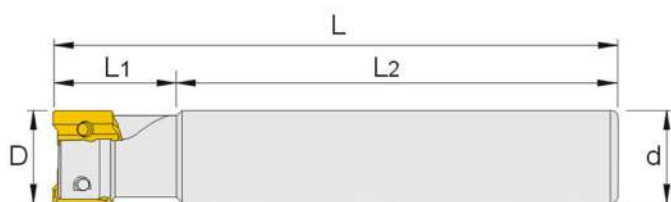
直角高速銑刀 90° Square Shoulder End Mills



HWEX直角高速銑刀-AXMT1235系列

90° 單位:mm

訂購編號 Order No.	型號 Model	刀徑 D	刀長 L	刀長1 L1	刀長2 L2	柄徑 d	刀具刃數	刀片類型 Inserts	扳手 Wrench	螺絲 Screw
68350-01	HWEX12-1616-100L-2T	16	100	25	75	16	2	AX□T1235	T8	M3.0-6.0-3.8-60
68350-02	HWEX12-1716-100L-2T	17	100	25	75	16	2			
68350-03	HWEX12-1816-100L-2T	18	100	25	75	16	2			
68350-04	HWEX12-2020-110L-3T	20	110	30	80	20	3			
68350-05	HWEX12-2220-110L-3T	22	110	30	80	20	3			
68350-06	HWEX12-2525-120L-4T	25	120	35	85	25	4			

HWEX直角高速銑刀-AXMT1705系列

單位:mm

訂購編號 Order No.	型號 Model	刀徑 D	刀長 L	刀長1 L1	刀長2 L2	柄徑 d	刀具刃數	刀片類型 Inserts	扳手 Wrench	螺絲 Screw
68360-01	HWEX17-2525-120L-2T	25	120	35	85	25	2	AX□T1705	T15	M4.0-9.0-5.6-60
68360-02	HWEX17-2625-120L-2T	26	120	35	85	25	2			
68360-03	HWEX17-3025-130L-3T	30	130	40	90	25	3			
68360-04	HWEX17-3232-130L-3T	32	130	40	90	32	3			
68360-05	HWEX17-3532-130L-3T	35	130	40	90	32	3			
68360-06	HWEX17-4032-170L-4T	40	170	50	120	32	4			

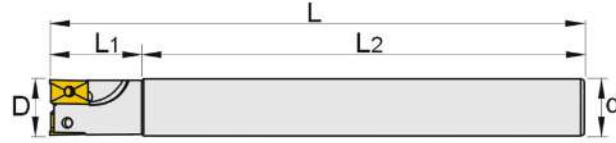

切削工具
CUTTING TOOL

68370
BAP
直角高速銑刀 90° Square Shoulder End Mills

BAP直角高速銑刀-1135系列

90° 單位:mm

訂購編號 Order No.	型號 Model	刀徑 D	柄徑 d	全長 L	刃長1 L1	刃長1 L2	刀具 刃數	刀片類型 Inserts	扳手 Wrench	螺絲 Screw
68370-01	BAP-1212-100L-1T	12	12	100	25	75	1	AP□□1135	T8	M2.5-6.0-3.5-60
68370-02	BAP-1516-150L-2T	15	16	150	25	125	2			
68370-03	BAP-1616-120L-2T	16	16	120	25	95	2			
68370-04	BAP-1616-160L-2T	16	16	160	25	135	2			
68370-05	BAP-1920-150L-2T	19	20	150	30	120	2			
68370-06	BAP-2020-120L-2T	20	20	120	35	85	2			
68370-07	BAP-2020-150L-3T	20	20	150	35	85	3			
68370-08	BAP-2020-150L-2T	20	20	150	35	115	2			
68370-09	BAP-2020-200L-2T	20	20	200	35	165	2			
68370-10	BAP-2525-150L-3T	25	25	150	35	115	3			
68370-11	BAP-2525-150L-3T	25	25	150	35	115	3			

BAP直角高速銑刀-1604系列

90° 單位:mm

訂購編號 Order No.	型號 Model	刀徑 D	柄徑 d	全長 L	刃長1 L1	刃長1 L2	刀具 刃數	刀片類型 Inserts	扳手 Wrench	螺絲 Screw
68380-01	BAP-2525-150L-2T	25	25	150	35	115	2	AP□□1604	T15	M4-10-5.7-60
68380-02	BAP-2525-200L-3T	25	25	200	35	125	3			
68380-03	BAP-2525-300L-3T	25	25	300	35	95	3			
68380-04	BAP-3232-120L-3T	32	32	120	45	135	3			
68380-05	BAP-3232-150L-3T	32	32	150	45	120	3			
68380-06	BAP-3232-200L-3T	32	32	200	45	85	3			
68380-07	BAP-3232-250L-3T	32	32	250	45	85	3			
68380-08	BAP-3232-300L-3T	32	32	300	45	115	3			
68380-09	BAP-3532-200L-3T	35	32	200	45	165	3			
68380-10	BAP-3532-250L-3T	35	32	250	45	115	3			
68380-11	BAP-3532-300L-3T	35	32	300	45	115	3			



 切削工具
CUTTING TOOL

切削工具 Cutting Tool

68390

HWEXF

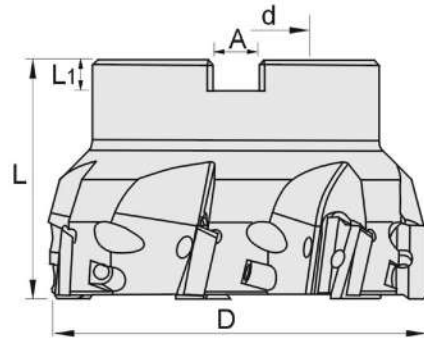
直角高速殼形銑刀 90° Square Shoulder Facing End Mills



90° 單位:mm

訂購編號 Order No.	型號 Model	刀徑 D	孔徑 d	全長 L1	深度 L	A	刀具 刃數	刀片類型 Inserts	扳手 Wrench	螺絲 Screw
68390-01	HWEXF-50-FMB22-5T	50	22	6.3	40	10.4	5	AX□T1705	T15	M4.0-9.0-5.6-60
68390-02	HWEXF-63-FMA25.4-6T	63	25.4	6.3	50	9.5	6			
68390-03	HWEXF-80-FMA25.4-7T	80	25.4	6.3	50	9.5	7			
68390-04	HWEXF-100-FMA31.75-8T	100	31.75	7.5	63	12.7	8			
68390-05	HWEXF-125-FMA38.1-9T	125	38.1	9.5	63	15.9	9			

HWEX切削數據表-1

刀片 Ø20, AXMT1235, 切深3mm, 切寬12.5mm Ø30, AXMT1705, 切深5mm, 切寬16mm

被切削材	硬度 (HB)	材質 fz(mm/z)	ACP100			ACP200			ACP300			ACP100			ACP200			ACP300		
			0.08	0.15	0.20	0.08	0.15	0.20	0.08	0.15	0.20	0.12	0.25	0.35	0.12	0.25	0.35	0.12	0.25	0.35
P 低合金鋼	低碳鋼	125	380	350	330	350	330	315	330	330	295	400	370	350	370	350	330	350	330	310
	中碳鋼	190	285	255	235	255	235	220	235	235	200	300	270	250	270	250	230	250	230	210
	中碳鋼	250	235	210	190	210	190	170	190	190	150	250	220	200	220	200	180	200	180	160
	碳素鋼	270	190	165	143	171	152	133	152	152	115	200	170	150	180	160	140	160	140	120
	碳素鋼	300	145	115	95	115	95	75	95	95	55	150	120	100	120	100	80	100	80	60
	低合金鋼	180	265	235	220	235	220	200	220	220	180	280	250	230	250	230	210	230	210	190
	低合金鋼	275	170	145	125	150	130	115	130	130	95	180	150	130	160	140	120	140	120	100
	低合金鋼	300	150	125	105	135	115	95	115	115	75	160	130	110	140	120	100	120	100	80
	低合金鋼	350	125	95	75	105	85	65	85	85	45	130	100	80	110	90	70	90	70	50
	高合金鋼	200	235	210	190	210	190	170	190	190	150	250	220	200	220	200	180	200	180	160
高合金鋼	325	125	95	75	95	75	55	75	75	35	130	100	80	100	80	60	80	60	40	
M 不銹鋼	SUS403(馬氏體)	200	200	170	150	170	150	130	150	150	115	210	180	160	180	160	140	160	140	120
	SUS403(馬氏體淬火)	240	170	140	125	140	125	105	125	125	85	180	150	130	150	130	110	130	110	90
	SUS304, SUS316(奧氏體)	180	220	190	170	190	190	150	170	170	130	230	200	180	200	180	160	180	160	140

ISO	被切削材	硬度 (HB)	材質 fz(mm/z)	ACK200			ACK300			DL1000			ACK200			ACK300			DL1000		
				0.08	0.15	0.20	0.08	0.15	0.20	0.05	0.15	0.20	0.12	0.25	0.35	0.12	0.25	0.35	0.05	0.15	0.20
S	鑄鐵			285	255	235	255	235	220				300	270	250	270	250	230			
	球墨鑄鐵			190	160	140	160	140	125				200	170	150	170	150	130			
K	難削切材	200		45	25		45	25					50	30		50	30				
	耐熱合金, 超合金, 鈦合金	280		45	25		45	25					50	30		50	30				
N	鋁合金, Si < 13%									1000	750	500							1000	750	500
	鋁合金, Si > 13%									250	200	170							250	200	170
	銅合金									350	330	300							350	330	300

切削工具
CUTTING TOOL

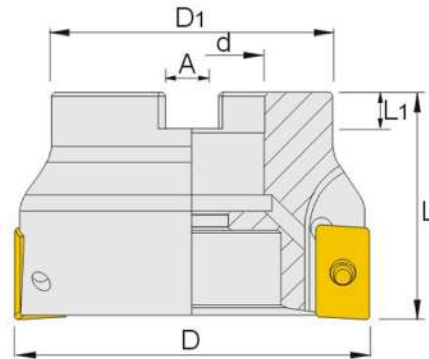
68400
HFM90°
90度直角殼形銑刀(中心出水)
90° Square Shoulder Facing End Mills

90° 單位:mm

訂購編號 Order No.	型號 Model	刀徑 D	刀徑1 D1	柄徑 d	刀長 L	深度 L1	A	刀具 刃數	刀片類型 Inserts	扳手 Wrench	螺絲 Screw
68400-01	HFM90-50-25.4-5T	50	48	25.4	40	6.3	10.4	5	AP□□1604	T15	M4-10-5.7-60
68400-02	HFM90-63-25.4-5T	63	48	25.4	40	6.3	10.4	5			
68400-03	HFM90-80-31.75-6T	80	60	31.75	50	7	12.4	6			
68400-04	HFM90-100-31.75-7T	100	78	31.75	50	8	14.4	7			
68400-05	HFM90-125-38.1-8T	125	89	38.1	63	9	16.4	8			
68400-06	HFM90-50-22-5T	50	48	22	40	6.3	10.4	5			
68400-07	HFM90-63-22-5T	63	48	22	40	6.3	10.4	5			
68400-08	HFM90-80-27-6T	80	60	27	50	7	12.4	6			
68400-09	HFM90-100-32-7T	100	78	32	50	8	14.4	7			
68400-10	HFM90-125-40-8T	125	89	40	63	9	16.4	8			

1.另有中心出水設計,降低刀具損耗。



 切削工具
CUTTING TOOL

切削工具 Cutting Tool

68410

HDNX25°

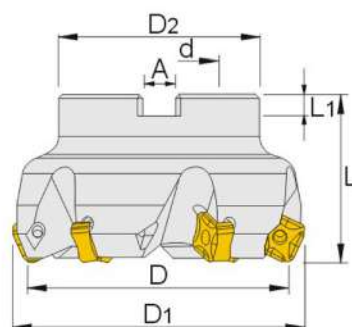
高切深殼形銑刀 Face Milling Cutter



25° 單位:mm

訂購編號 Order No.	型號 Model	刀徑 D	刀寬1 D1	刀寬2 D2	孔徑 d	全長 L	深度 L1	A	刀具 刃數	刀片類型 Inserts	扳手 Wrench	螺絲 Screw
68410-01	HDNX-080-25.4-6T	80	88	60	25.4	50	6	9.5	6	SNMT1205	T15	M4-12-5.7-60
68410-02	HDNX-100-31.75-7T	100	108	70	31.75	50	8	12.7	7			
68410-03	HDNX-125-38.1-8T	125	133	80	38.1	63	10	15.9	8			
68410-04	HDNX-160-50.8-10T	160	166	100	50.8	63	11	19	10			

特色:

1. 切深最大可達8mm,效率增加。
2. 刀片可使用8角(雙面皆可使用),經濟實惠。
3. 依加工需求,刀片及刀具可有多種選擇。
4. 加工鑄鐵、鑄鋼效果好,壽命佳。

HDNX切削數據表

單位:mm

ISO	被切削材	硬度(HB)	切削速度 Vc(m/min)	進給量 Fz(mm/t)	推薦材質
P	碳素鋼	180~280	150-175-200	0.10-0.15-0.20	ACP200
	合金鋼	180~280	150-175-200	0.10-0.15-0.20	ACP200
K	鑄鐵	250	150-225-300	0.10-0.20-0.30	ACK200,ACK300
	球墨鑄鐵	250	150-200-250	0.10-0.18-0.25	ACK200,ACK300

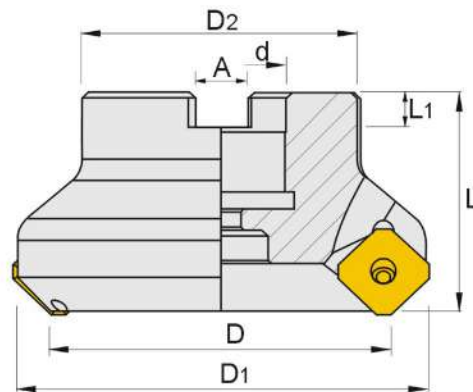
68420
ASX45°
45度殼形銑刀(中心出水) 45° Face Milling Cutter

45° 單位:mm

訂購編號 Order No.	型號 Model	刀徑 D	刀寬1 D1	刀寬2 D2	孔徑 d	全長 L	深度 L1	A	刀具 刃數	刀片類型 Inserts	扳手 Wrench	螺絲 Screw
68420-01	ASX45-50-25.4-4T	50	63	48	25.4	40	6.3	10.4	4	SE□□13T3□□ (日)	T15	M3.5-10-5.5-60
68420-02	ASX45-63-25.4-5T	63	76	50	25.4	40	6.3	10.4	5			
68420-03	ASX45-80-31.75-6T	80	93	62	31.75	50	7	12.4	6			
68420-04	ASX45-100-31.75-7T	100	113	62	31.75	50	8	14.4	7			
68420-05	ASX45-125-38.1-8T	125	138	89	38.1	63	9	16.4	8			
68420-06	ASX45-50-22-4T	50	63	48	22	40	6.3	10.4	4			
68420-07	ASX45-63-22-5T	63	76	48	22	40	6.3	10.4	5			
68420-08	ASX45-80-27-6T	80	93	62	27	50	7	12.4	6			
68420-09	ASX45-100-32-7T	100	113	78	32	50	8	14.4	7			
68420-10	ASX45-125-40-8T	125	138	89	40	63	9	16.4	8			

1. 刀刃不等距設計,增加刀片壽命及效率。
2. 熱處理后再精修,抗震高、硬度佳、刀具更精准。
3. 另有中心出水設計,降低刀具的損耗。

 切削工具
CUTTING TOOL



Copyright © Gin Tech Precision Co., Ltd. All Rights Reserved



機械
配件
型錄

30SS

Gin Tech reserves right to amend the product content without prior notice

精展精密科技股份有限公司(總公司)
GIN TECH PRECISION CO., LTD.

台灣238新北市樹林區保安街一段341巷7號
Address: No 7, Lane 341, Sec. 1, Bau An Street, Shu lin Dist.,
23841, New Taipei City, Taiwan
TEL: 886-2-2681-8596 (Rep.)  Sales@ginchan.com.tw
FAX: 886-2-2681-8516  www.gin-chan.com

東莞美商精展機械五金有限公司
東莞市精展機械五金有限公司
GIN CHAN MACHINERY & HARDWARE CO., LTD.(DONGGUAN)

廣東省東莞市大朗鎮石廈村金沙崗二路27號
TEL : 86-769-8318-5858 (Rep.)
FAX: 86-769-8318-5838/8313-5003
 www.ginchan.com.cn  sales@ginchan.com.cn



Scan Now!



GIN TECH PRECISION CO., LTD.

製作印冊: 王聖 13602265385