

# Magnetic Tools

## Grinding Accessories



C01-C62

B37~48

EDM Fixture Clamp (Stainless)



53200 B37



53210 B37



53210-00 B39



53210-03/04/05 B40



53210-07/08 B41



53210-09/10 B42



53300 B43



53310 B43



53320 B43



53330 B44



53340 B44



53342 B45



53346 B45



53350 B46



53360 B46



53370 B46



53380 B46



53390 B47



53400 B47



53410 B47



53420 B47



53412 B48



53422 B48

C01~13

Induction Block / Sine Magnetic Chuck



54000 C01



54010 C01

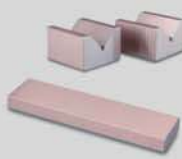

54020 C02



54030 C03

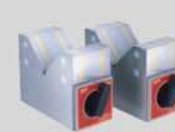

54040 C04



54050 C05



54058 C06



54060 C06



54065 C07



54070 C08



54080 C09



54090 C09



54100 C10



54110 C11



54120 C11



54130 C12



54140 C12



54150 C13

# INDEX

C13~36

## Magnetic Chucks



54160 C13



54170 C14



54180/90 C15



54200 C16

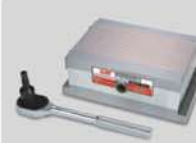

54210 C16



54220 C17

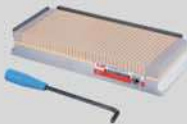

54230 C17



54240 C18



54250 C19



54260 C20

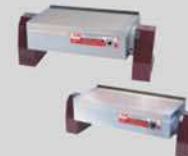

54300/10 C21



54320 C22



54330 C23



54340 C24

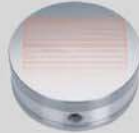

54350 C25



54360 C26



54500 C27



54540 C28



54550 C29



54560 C30



54600 C31



54610 C33



54620 C35

C37~44

## Demagnetizer / Chips Cleaner



54810 C37



54816 C37



54820 C38



54822 C38



54824 C38



54826 C39



54828 C39



54830 C40



54832 C40



54834 C41



54836 C41



54838/40 C42



54850 C43



54856 C43



54858 C44



54860 C44



**C45~54**
**Magnetic Tools / Magnetic Base**

**C55~64**
**Universal Arm**





# Magnetic Tools

## 54000 GT Magnetic Induction Block

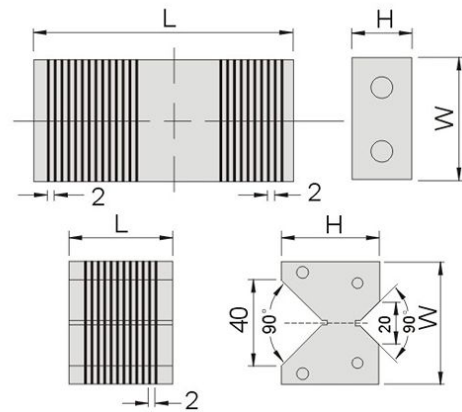

### Features :

- ▶ Non-magnetic GT1, GT2 and GT3 can be magnetized after inducted on any magnetic chuck applying for as plate or 45° fixture.
- ▶ It is used as auxiliary tool by applying with magnetic chuck for holding round, thin or shapes that difficult to hold.
- ▶ There are mainly two types of induction blocks, rectangle and M shape for different processing demands.



Unit:mm

Order No.	Model	L	W	H	Qty	N.W.
54000-10	GT1	100	50	25	2	2kg
54000-20	GT2	49	58	46	2	1.7kg
54000-30	GT3	100	58	46	1	3.4kg

MAGNETIC TOOLS

## 54010 AT Magnetic Induction Block (Aluminium made)

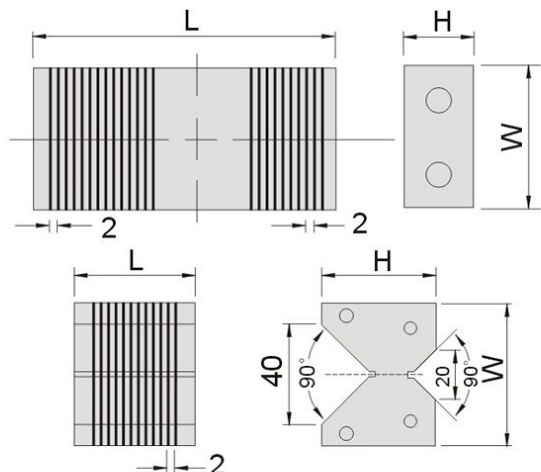
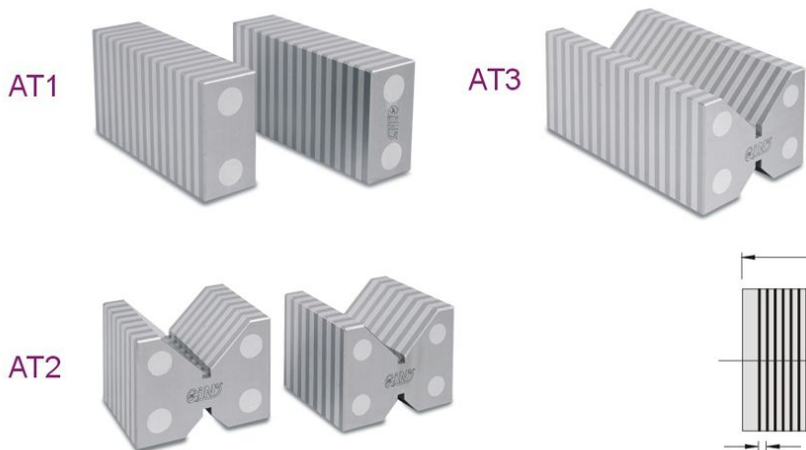

Unit:mm

Order No.	Model	L	W	H	Qty	N.W.
54010-10	AT1	100	50	25	2	1.2kg
54010-20	AT2	49	58	46	2	1.2kg
54010-30	AT3	100	58	46	1	1.2kg

# 54020 HT Magnetic Induction Block

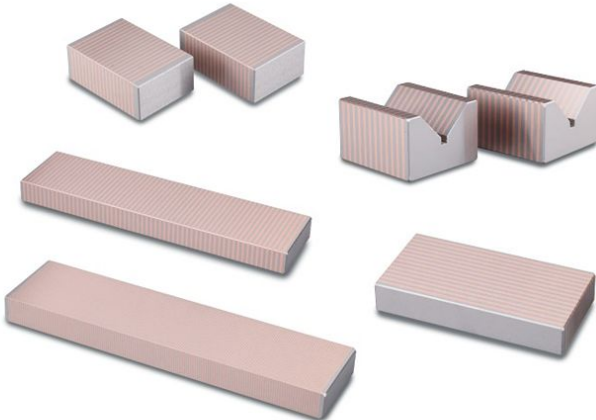

### Features :

- ▶ Made of iron and copper with brazing welding fixed, can cut in any shapes and will not deform easily.
- ▶ It will be magnetized after inducted on any magnetic chuck applying for as plate or 45° fixture and used as auxiliary tool for holding round, thin or shapes that difficult to hold.
- ▶ There magnetic block itself is not mannetic, and it can be magnetic by placed on a magnetic chuck, which can then be used for effective processing.
- ▶ 20% magnetic force reduced when thickness over 25mm.

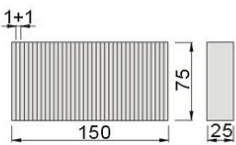

54020-01 HTW-150

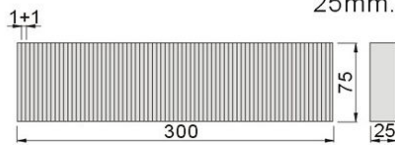

54020-02 HTW-300

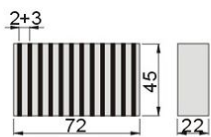

54020-03 HT-75

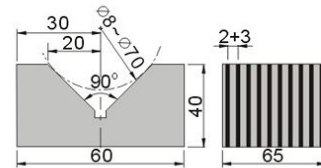

54020-04 HTV-60

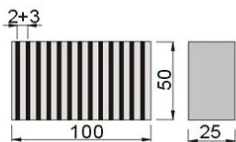

54020-05 HT-100

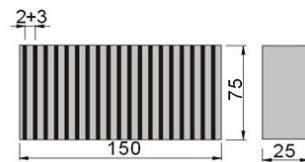

54020-06 HT-150

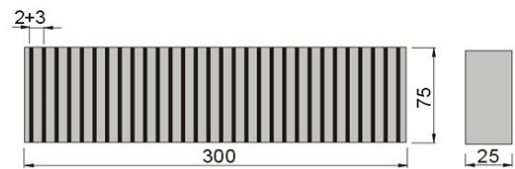

54020-07 HT-300

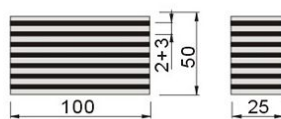

54020-08 HTL-100

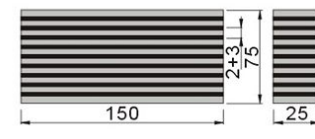

54020-09 HTL-150

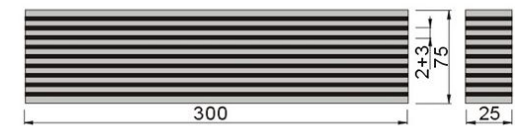

54020-10 HTL-300

Unit:mm

Order No.	Model	L	W	H	Pole pitch	Qty	N.W.
54020-01	HTW-150	150	75	25	2(1+1)	1 PCS	2.2kg
54020-02	HTW-300	300	75	25	2(1+1)	1 PCS	4.4kg
54020-03	HT-75	72	45	22	5(2+3)	2 PCS	1.2kg
54020-04	HTV-60	65	60	40	5(2+3)	2 PCS	2.5kg
54020-05	HT-100	100	50	25	5(2+3)	2 PCS	2.0kg
54020-06	HT-150	150	75	25	5(2+3)	1 PCS	2.2kg
54020-07	HT-300	300	75	25	5(2+3)	1 PCS	4.4kg
54020-08	HTL-100	100	50	25	5(2+3)	2 PCS	2.0kg
54020-09	HTL-150	150	75	25	5(2+3)	1 PCS	2.2kg
54020-10	HTL-300	300	75	25	5(2+3)	1 PCS	4.4kg



# Magnetic Tools

## 54030 GVH Magnetic V-block

GVH2



GVH1



GVH3

### Features :

- ▶ Suitable for applying as a plate or 45° fixture and used as auxiliary tool for holding round, thin or shapes that difficult to hold.
- ▶ Light grinding, milling, tapping, drilling is applicable.
- ▶ Strong mag. force on top, bottom and V groove.
- ▶ Suitable for applying two types accuracy job, standard or special.
- ▶ On/Off switch, easy for operation and portable.

MAGNETIC TOOLS

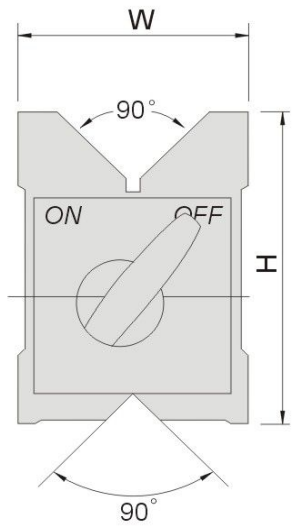
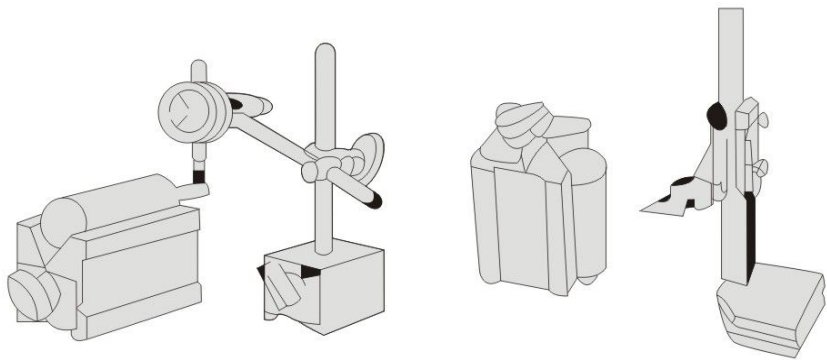

Unit:mm

Order No.	Model	Mag. Force		Specification			N.W.
		Round	Flat	L	W	H	
54030-10	GVH1	55kgf	70kgf	80	56	72	1.8kg
54030-20	GVH2	90kgf	110kgf	115	76	100	5.1kg
54030-30	GVH3	55kgf	70kgf	120	61	73	3.1kg



**54040** GVH Magnetic V-block

GVH30

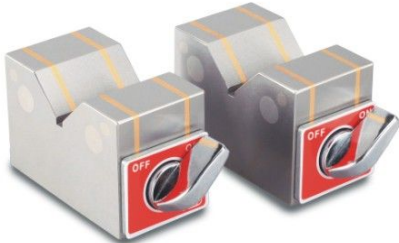

GVH40



GVH60



**Features :**

- ▶ GVH30/40/60 are suitable for applying long or round workpiece.
- ▶ Suitable for holding round or rectangle shape steel for precision measuring, marking and grinding.
- ▶ Two pieces in a set with uniform spec. for standard and accuracy.
- ▶ On/Off switch, easy for operation and portable.
- ▶ Sold in a pair.

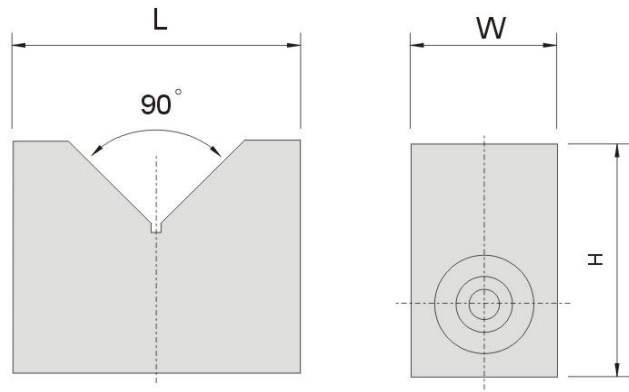

MAGNETIC TOOLS

Unit:mm

Order No.	Model	Mag. Force	Capacity	Specification			N.W.
				L	W	H	
54040-30	GVH30	15kgf	∅50	70	40	50	2kg
54040-40	GVH40	20kgf	∅80	100	50	80	6kg
54040-60	GVH60	23kgf	∅125	150	50	100	10kg

# Magnetic Tools

## 54050 BA Magnetic Square Block



### Features :

- ▶ Suitable for holding round or rectangle shape steel for precision measuring and marking.
- ▶ Magnetic suction is available on both sides, top face & v-face.
- ▶ V-face is provided at 2 sections each at right angle for easy application.
- ▶ Precisely ground and inspected.

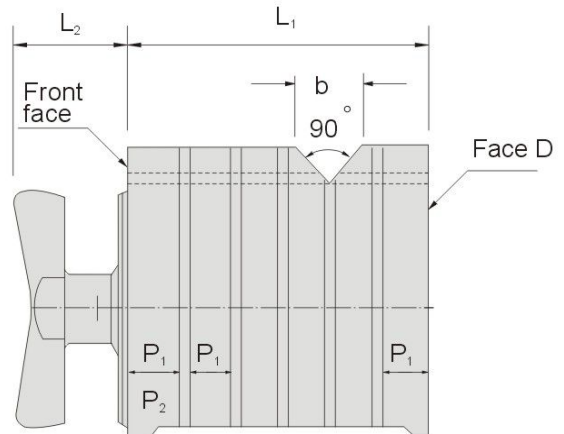
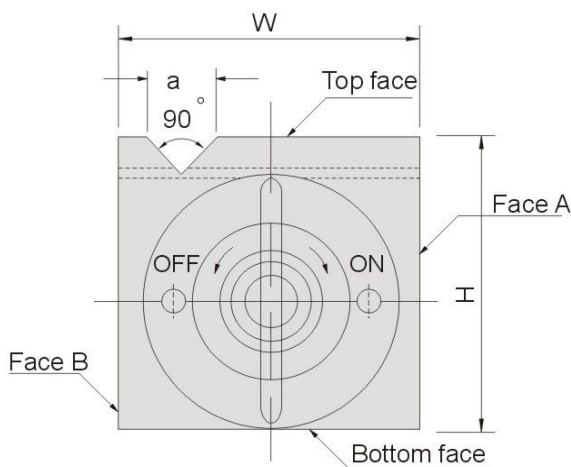
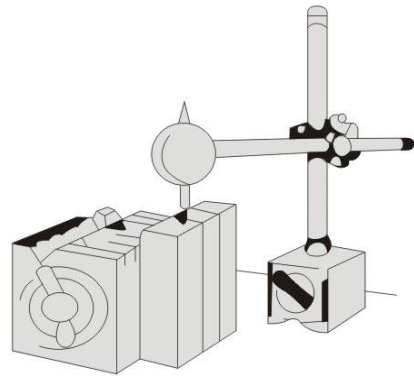

Unit:mm

Order No.	Model	V-Face Holding Power		Flat-Face Holding Power	
		Steel	Cast iron	Steel	Cast iron
54050-10	BA1	30kgf	25kgf	50kgf	30kgf
54050-20	BA2	60kgf	35kgf	180kgf	100kgf

Order No.	Model	Specification								N.W.
		W	L1	H	L2	P1	P2	P3	a/b	
54050-10	BA1	100	100	100	43	17	4	12	26	6.3kg
54050-20	BA2	150	150	150	56	24.5	5	19	32	21.3kg

**54058** DSM Double-Sided Permanent Magnetic Chuck



**Features :**

- ▶ Suitable for surface grinder, EDM & for inspection purpose.
- ▶ Lightweight & operation simple.
- ▶ Good in waterproof.
- ▶ Other lateral faces also have magnetic.

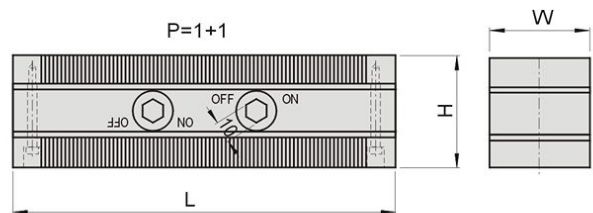

Order No.	Model	Spec.	Specification			Pole Pitch	N.W.
			L	W	H		
54058-01	DSM-15	50x150	150	50	58	2(1+1)	3.5kg
54058-02	DSM-20	50x200	200				4.7kg
54058-03	DSM-25	50x250	250				5.9kg

Unit:mm

**54060** MWL Permanent Magnetic Chuck

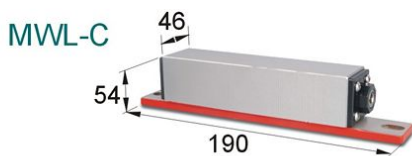
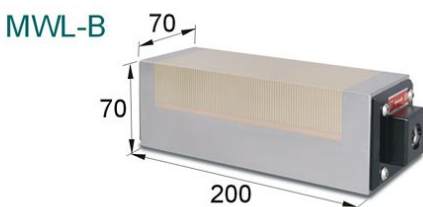
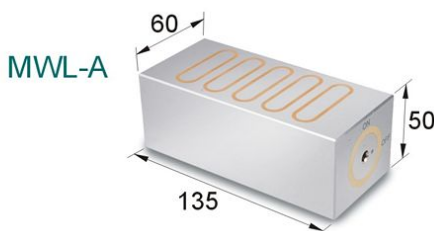

(Wire cutting machine applicable)

**Features :**

- ▶ Suitable for applying in grinding, milling, EDM, Wire Cutting and measuring machines.
- ▶ Attractions are available on several faces and capable of holding small and thing workpieces. Attraction can be adjustable and prevent distortion.
- ▶ Suitable for processing 90° fixture.
- ▶ Applying two magnetic chucks for shifting processing, easier and efficient.
- ▶ Easily to disassemble workpieces when OFF, no magnetic force remained.

Order No.	Model	Pole Pitch	N.W.
54060-01	MWL-A	10(2+6+2)	3.5kg
54060-02	MWL-B	2(0.5+1.5)	7.5kg
54060-03	MWL-C	2(1+1)	3.7kg

Unit:mm



# Magnetic Chuck

## 54065 MWT Stainless Steel Square Permanent Magnetic Chuck



Example:



### Features :

- ▶ As example shown, the ground work-piece is taken to a datum surface on the datum side of the magnetic chuck, and then the uppermost surface is ground to obtain both sides for precision squareness surfaces.
- ▶ Bottom plate is made of SUS420 for rusty resistance and the top plate is made of SUS304 & SS400 with heat treatment and maintenance shall be carried out for SS400 after use. Applying ceramic-like magnet with good wear-resistance.
- ▶ Squareness with datum and each sides is within 0.003mm.

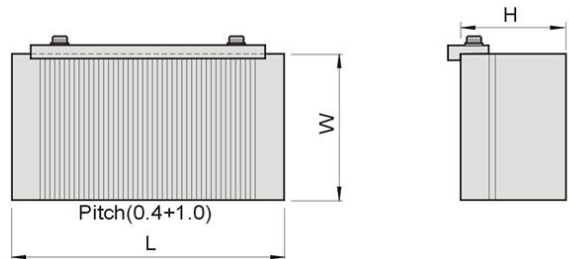

Unit:mm

Order No.	Model	W	L	H	Pole Pitch	N.W.
54065-01	MWT0813	80	130	65	1.4 (0.4+1.0)	7.0kg
54065-02	MWT1020	100	200	65		10.0kg
54065-03	MWT1515	150	150	80		25.0kg

**54070** MWS Permanent Magnetic Chuck (Vertical Type)



**Features :**

- ▶ Suitable for applying workpiece inspection of vertical auxiliary by using its magnetic force to achieve stability.
- ▶ Sub-zero treatment and HRC56° ensure its accuracy, material SKD11 is applied for its base.
- ▶ Squareness and parallelism are within  $\pm 0.002\text{mm}$ .

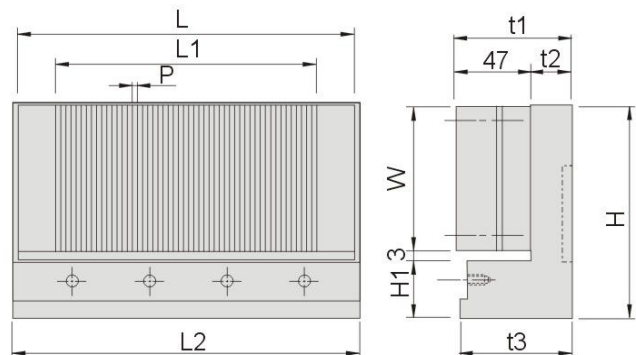
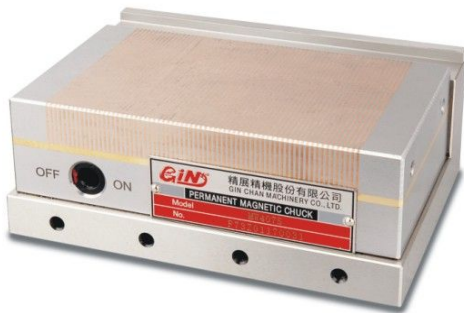

MAGNETIC TOOLS

Unit:mm

Order No.	Model	W	L	L1	P	L2	t3	t1	t2	H	H1	N.W.
54070-10	MW307S	75	175	130	1+1	180	65	67	20	111	30	9.7kg
54070-20	MW407S	100	175	130	1+1	180	65	67	20	136	30	13kg
54070-30	MW510S	125	250	205	1+1	255	65	67	20	161	30	23kg

# Sine Plate

## 54080 SP Sine Plate



### Features :

- ▶ Tapped holes in top plate 3" x 6" , 5" x 6" for fixing workpieces.
- ▶ Squareness within 0.0002"
- ▶ Parallelism within 0.0002" / 4".
- ▶ Center distance of rolls within 0.0002".
- ▶ Adjustable angle 0-60°

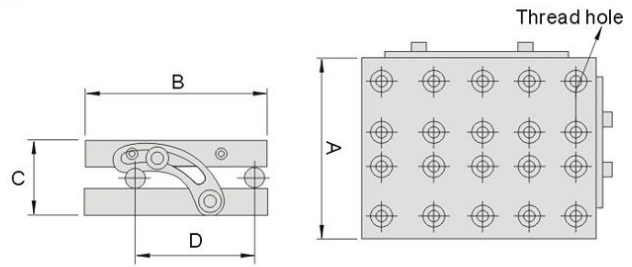

Unit: Inch

Order No.	Model	A	B	C	D	Thread hole	N.W.
54080-15	SP36	3.228	6	2.205	5	1/4"-20UNC	4.2kg
54080-25	SP56	5	6	2.362	5		7kg

MAGNETIC TOOLS

## 54090 SP Sine Plate



### Features :

- ▶ Tapped holes on top plates for fixing workpieces.
- ▶ Squareness within 0.005mm (0.0002")
- ▶ Parallelism within 0.005mm (0.0002") / 100mm
- ▶ Center distance of rolls within 0.005mm. (0.0002")
- ▶ Adjustable angle 0-60°.

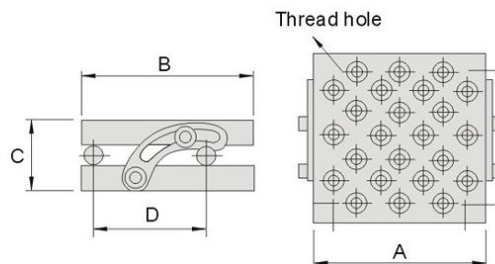

Metric / Inch

Order No.	Model	A	B	C	D	Thread hole	N.W.
54090-10	SP47	175	100	60	75	M6x1.0	6.5kg
54090-15		7	100	4	2.362	3	
54090-20	SP66	150	150	60	100	M6x1.0	8.1kg
54090-25		6	150	6	2.362	5	
54090-30	SP612	300	150	60	100	M10x1.5	15.8kg
54090-35		12	150	6	2.362	5	



**54100** CSP Compound Sine Plate



**Features :**

- ▶ Widely applied on grinding or milling machines with compound angle adjustable.
- ▶ Made of quality steel, hardened to 55°~ 58°.
- ▶ Parallelism within 0.005mm(0.0002") / 100mm
- ▶ Center distance of rolls within 0.005mm (0.0002").
- ▶ Adjustable angle 0-60°.

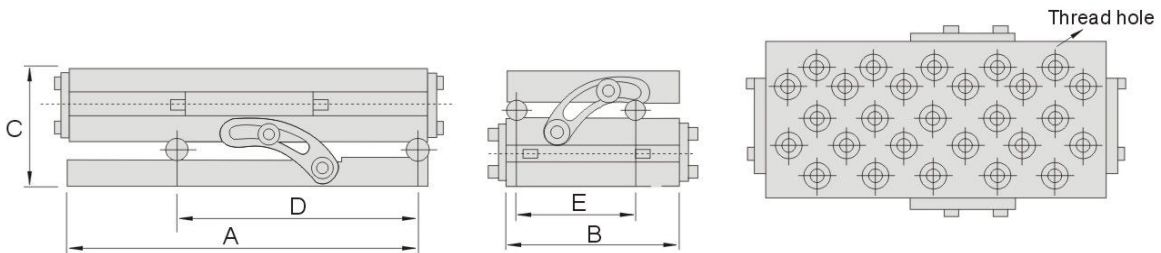

Metric  
Inch

Order No.	Model	A	B	C	D	E	Thread hole	N.W.
54100-10	CSP47	175	100	100	100	75	M6x1.0	9.7kg
54100-15		7	4	4	5	3	1/4"-20UNC	
54100-20	CSP66	150	150	100	100	100	M6x1.0	12.2kg
54100-25		6	6	4	5	5	1/4"-20UNC	
54100-30	CSP612	300	150	100	200	100	M10x1.5	23.4kg
54100-35		12	6	4	10	5	3/8"-16UNC	

# Sine Magnetic Chuck

## 54110 SPM Economy Sine Magnetic Chuck



Metric  
Inch

### Features :

- ▶ This Sine Magnetic Chuck provides user-friendly and cost effective.
- ▶ Parallelism within 0.003mm / 100mm
- ▶ Center distance of rolls within 0.005mm.
- ▶ Adjustable angle 0-60° For sine angle calculation refer to 55070

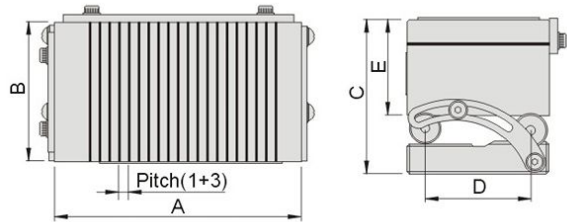

Order No.	Model	A	B	C	D	E	N.W.
54110-10 / 54110-15	SP47M	175 / 7	100 / 4	85.4 / 3.4	75 / 3	47 / 1.85	10.4kg
54110-20 / 54110-25	SP66M	150 / 6	150 / 6	85.4 / 3.4	100 / 5	47 / 1.85	12.6kg
54110-22 / 54110-27	SP510M	250 / 10	125 / 5	85.4 / 3.4	100 / 4	47 / 1.85	17.8kg
54110-30 / 54110-35	SP612M	300 / 12	150 / 6	85.4 / 3.4	100 / 5	47 / 1.85	25.4kg

## 54120 CSPM Compound Sine Magnetic Chuck



Metric  
Inch

### Features :

- ▶ Base is hardened with precision ground and high rigidity.
- ▶ Parallelism within 0.003mm / 100mm
- ▶ Center distance of rolls within 0.005mm.
- ▶ Adjustable angle 0-60° For sine angle calculation refer to 55070

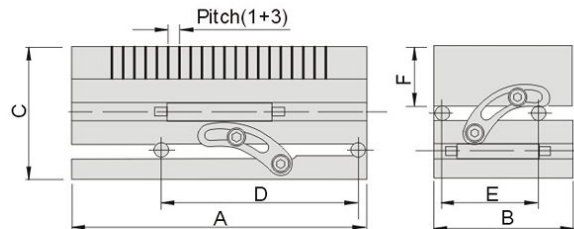

Order No.	Model	A	B	C	D	E	F	N.W.
54120-10 / 54120-15	CSP47M	175 / 7	100 / 4	123.7 / 4.9	100 / 5	75 / 3	47 / 1.85	13.5kg
54120-20 / 54120-25	CSP66M	150 / 6	150 / 6	123.7 / 4.9	100 / 5	100 / 5	47 / 1.85	16.8kg
54120-22 / 54120-27	CSP510M	250 / 10	125 / 5	123.7 / 4.9	200 / 8	100 / 4	47 / 1.85	23.4kg
54120-30 / 54120-35	CSP612M	300 / 12	150 / 6	123.7 / 4.9	200 / 10	100 / 5	47 / 1.85	32.5kg

MAGNETIC TOOLS

**54130** SPS Economy Sine Plate With Fine Magnetic Chuck



Metric  
Inch

**Features :**

- ▶ Suitable for thin and small workpiece processing.
- ▶ Parallelism within 0.003mm / 100mm
- ▶ Center distance of rolls within 0.005mm.
- ▶ Adjustable angle 0-60° For sine angle calculation refer to 55070

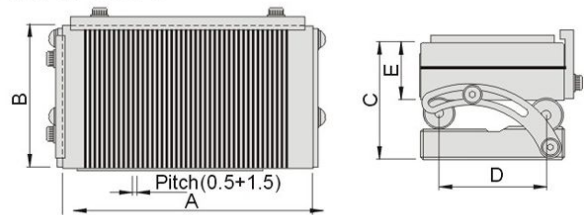

Order No.	Model	A	B	C	D	E	N.W.						
54130-10	54130-15	SP47S	175	7	100	4	85.4	3.4	75	3	47	1.85	10.3kg
54130-20	54130-25	SP66S	150	6	150	6	85.4	3.4	100	5	47	1.85	12.7kg
54130-22	54130-27	SP510S	250	10	125	5	85.4	3.4	100	4	47	1.85	18.3kg
54130-30	54130-35	SP612S	300	12	150	6	85.4	3.4	100	5	47	1.85	26.7kg

**54140** CSPS Compound Sine Plate With Fine Magnetic Chuck



Metric  
Inch

**Features :**

- ▶ Base is hardened with precision ground and high rigidity.
- ▶ Parallelism within 0.003mm / 100mm
- ▶ Center distance of rolls within 0.005mm.
- ▶ Adjustable angle 0-60° For sine angle calculation refer to 55070

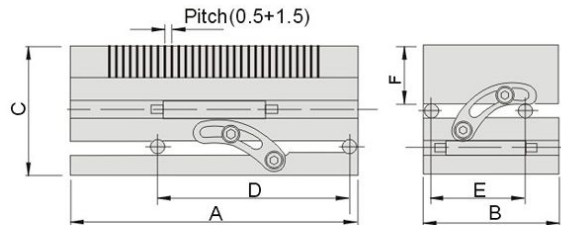

Order No.	Model	A	B	C	D	E	F	N.W.							
54140-10	54140-15	CSP47S	175	7	100	4	123.7	4.9	100	5	75	3	47	1.85	13.5kg
54140-20	54140-25	CSP66S	150	6	150	6	123.7	4.9	100	5	100	5	47	1.85	16.8kg
54140-22	54140-27	CSP510S	250	10	125	5	123.7	4.9	200	8	100	4	47	1.85	23.4kg
54140-30	54140-35	CSP612S	300	12	150	6	123.7	4.9	200	10	100	5	47	1.85	33.1kg

MAGNETIC TOOLS



# Sine Magnetic Chuck

## 54150 MSP Sine Plate With Fine Magnetic Chuck

PAT: 191154  
ZL 99 2 11094.7



### Features :

- ▶ This magnetic chuck is user-friendly and high precision auxiliary tools.
- ▶ Tiny workpiece can be attracted with pole pitch 1.5mm.
- ▶ Parallelism within 0.003mm / 100mm
- ▶ Center distance of rolls within 0.005mm.
- ▶ Adjustable angle 0-60° For sine angle calculation refer to 55070

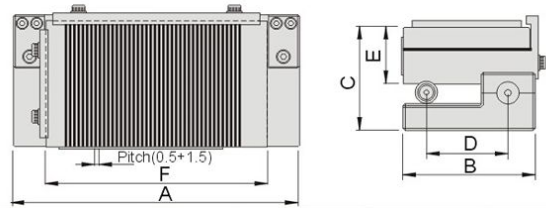

Metric  
Inch

Order No.	Model	A	B	C	D	E	F	N.W.
54150-10	MSP35S	174	78	74	50	40	130	6.5kg
54150-15	MSP35S	7	3	2.9	2	1.58	5	
54150-20	MSP47S	225	102	84	75	47	175	11kg
54150-25	MSP47S	9	4	3.3	3	1.85	7	
54150-30	MSP66S	200	152	84	100	47	150	14.8kg
54150-35	MSP66S	8	6	3.3	5	1.85	6	
54150-40	MSP510S	300	127	84	100	47	250	20kg
54150-45	MSP510S	12	5	3.3	4	1.85	10	
54150-50	MSP412S	350	102	84	75	47	300	20.3kg
54150-55	MSP412S	14	4	3.3	3	1.85	12	
54150-60	MSP612S	350	152	84	100	47	300	27.5kg
54150-65	MSP612S	14	6	3.3	5	1.85	12	

## 54160 CMSP Compound Sine Plate With Fine Magnetic Chuck



### Features :

- ▶ Base is hardened with precision ground and high rigidity.

- ▶ Parallelism within 0.003mm / 100mm
- ▶ Center distance of rolls within 0.005mm.
- ▶ Adjustable angle 0-60° For sine angle calculation refer to 55070

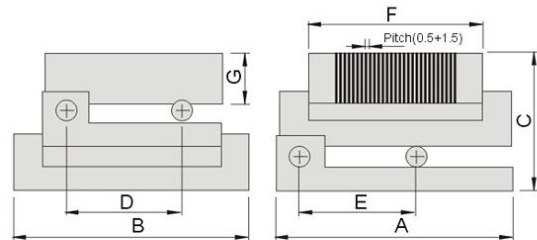

Metric  
Inch

Order No.	Model	A	B	C	D	E	F	G	N.W.
54160-10	CMSP35S	177	122	107.7	50	100	130	40	10kg
54160-15	CMSP35S	7	4.8	4.2	2	3	5	1.58	
54160-20	CMSP47S	225	150	121	75	150	175	47	16kg
54160-25	CMSP47S	9	6	4.8	3	5	7	1.85	
54160-30	CMSP66S	200	200	121	100	150	150	47	20.9kg
54160-35	CMSP66S	8	8	4.8	5	5	6	1.85	
54160-40	CMSP510S	300	175	121	100	200	250	47	28kg
54160-45	CMSP510S	12	7	4.8	4	10	10	1.85	

**54170** MSPSA Fine-tuning Sine Magnetic Chuck

MSP35SA



MSP47SA



MSP66SA



**Features :**

- ▶ This magnetic chuck has fine-tuning function with high accuracy and high stability.
- ▶ Tiny workpiece can be attracted with pole pitch 1.5mm.
- ▶ Parallelism within 0.003mm / 100mm
- ▶ Adjustable angle 0-55° For sine angle calculation refer to 55070.

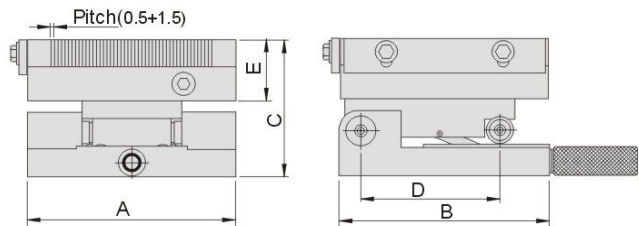
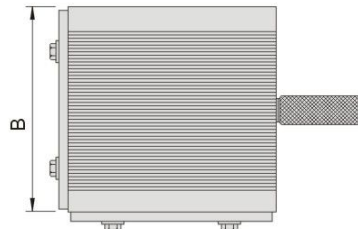

Unit:mm

Order No.	Model	A	B	C	D	E	N.W.
54170-35	MSP35SA	130	75	83	50	37	5.6kg
54170-47	MSP47SA	175	100	90	75	41	10.5kg
54170-66	MSP66SA	150	150	106	100	45	16.4kg

MAGNETIC TOOLS

# Magnetic Chuck

## 54180 MTW Super Thin Type Permanent Magnetic Chuck



### Features :

- ▶ Suitable for grinding, EDM and projection grinding machine.
- ▶ Thin & light in terms of dimensions.
- ▶ Water resistance.
- ▶ Apply by turns when mass production, increasing 50% efficiency.

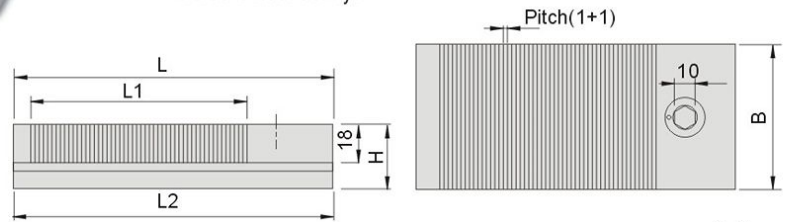

Unit:mm

Order No.	Model	Spec.	B	L	L1	Pitch	L2	H	N.W.
54180-305	MTW305	70X130	70	130	77	2(1+1)	130	30	2.2kg
54180-307	MTW307	70X175		175	122		175		2.9kg
54180-408	MTW408	100X200		100	200		147		220
54180-606	MTW606	150X150	150	150	97		150	36	6.4kg
54180-608	MTW608	150X200		200	147		220		8.5kg
54180-610	MTW610	150X250		250	197		270		10.6kg

MAGNETIC TOOLS

## 54190 MTS Super Thin Permanent Magnetic Chuck (Stainless steel)



### Features :

- ▶ Suitable for grinding, EDM and projection grinding machine.
- ▶ Thin & light in terms of dimensions.
- ▶ Water resistance.
- ▶ Apply by turns when mass production, increasing 50% efficiency.
- ▶ Stainless steel pole pitch. Made of stainless steel.

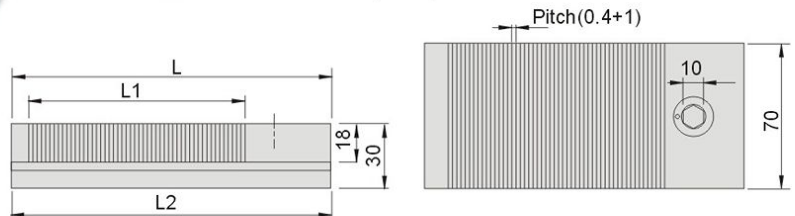

Unit:mm

Order No.	Model	Spec.	L	L1	Pitch	L2	N.W.
54190-305	MTS305	70X 130	130	77	1.4(0.4+1)	130	2.2kg
54190-307	MTS307	70X 175	175	122		175	2.9kg



**54200 HMR Permanent Magnetic Chuck(For Alloy Material)**



**Features :**

- ▶ Suitable for alloy and other metal materials which are difficult to hold.
- ▶ The top plate is brazing to ensure stability and accuracy.
- ▶ Magnetic force is up to 3500 gauss.
- ▶ Stainless steel made plate, high rigidity and durability.
- ▶ No ON-OFF switch.

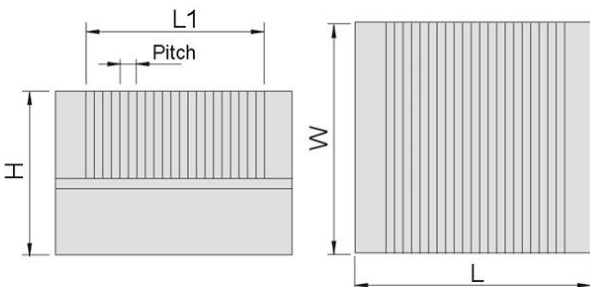

Unit:mm

Order No.	Model	Spec.	W	L	L1	Pitch	H	N.W.
54200-02	HMR-404	105X105	105	105	69	6 (1+1+ 1+3)	60	5.2kg
54200-04	HMR-407	105X180		180	145			9.0kg
54200-08	HMR-612	150X300	150	300	266			21.0kg

**54210 HMTR Permanent Magnetic Chuck(For Carbide Material)**



**Features :**

- ▶ Suitable for Tungsten and other metal materials which are difficult to hold.
- ▶ The top plate is brazing to ensure stability and accuracy.
- ▶ Magnetic force is up to 3000 gauss.
- ▶ On/Off switch design, turn 360°

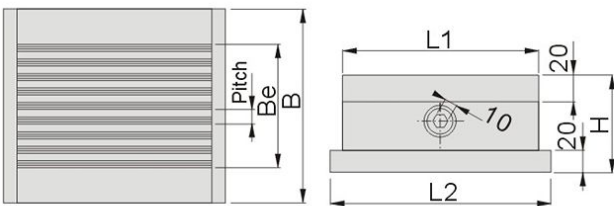

Unit:mm

Order No.	Model	Spec.	B	Be	Pitch	L1	L2	H	N.W.
54210-02	HMTR-1010L	100X100	100	50.0	11.2 (1.6+2+ 1.6+6)	100	125	94	7.8kg
54210-04	HMTR-1313L	130X125	130	72.4		125	155	80	11kg
54210-06	HMTR-1320L	130X200	130	87.6		200	230	80	16.3kg
54210-08	HMTR-1515L	150X150	150	94.8		150	170	80	13.9kg
54210-10	HMTR-1520L	150X200	150	110.8		200	230	80	18.2kg

MAGNETIC TOOLS

# Magnetic Chuck

## 54220 B Fine Pitch Permanent Magnetic Chuck

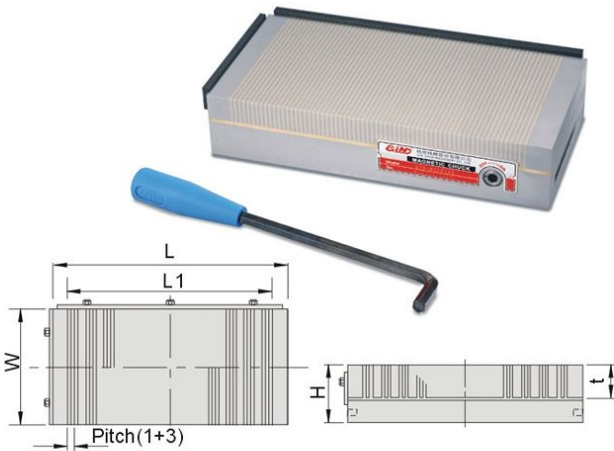

### Features :

- ▶ Suitable for surface grinding and EDM machines.
- ▶ Suitable for holding big and thick workpieces.
- ▶ Overall sealed water resistance.
- ▶ High precision with strong magnetic force up to 14 kgf/cm<sup>2</sup>.
- ▶ Thicker top plate is applied, extended lifecycle.
- ▶ Parallelism, flatness and squareness within 0.005mm/100mm.

Unit:mm

Order No.	Model	Spec.	W	L	L1	t	Pitch	H	N.W.
54220-02	407B	100X175	100	175	139	20	1+3	52	8kg
54220-04	510B	125X250	125	250	212				14kg
54220-06	612B	150X300	150	300	256			60	21.9kg
54220-08	614B	150X350	150	350	306				25.6kg
54220-09	616B	150X400	150	400	356				30.5kg
54220-10	618B	150X450	150	450	400				33.8kg
54220-12	816B	200X400	200	400	356				38.3kg
54220-14	818B	200X450	200	450	400				42.8kg
54220-16	820B	200X500	200	500	450				50.0kg

## 54230 E Normal Pitch Permanent Magnetic Chuck

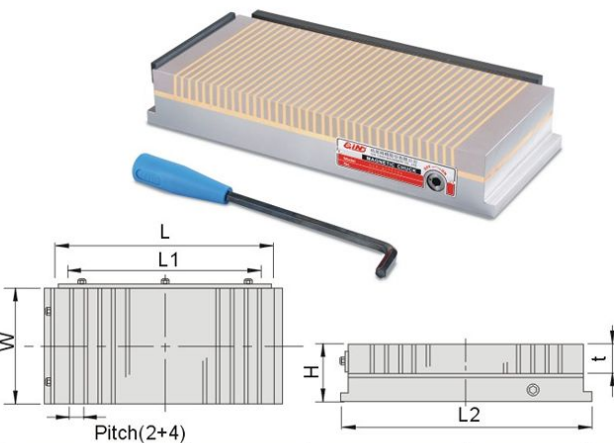

### Features :

- ▶ Suitable for surface grinding and EDM machines.
- ▶ Suitable for holding big and thick workpieces.
- ▶ Overall sealed water resistance.
- ▶ High precision with strong magnetic force up to 14 kgf/cm<sup>2</sup>.
- ▶ Thicker top plate is applied, extended lifecycle.
- ▶ Parallelism, flatness and squareness within 0.005mm/100mm.

Unit:mm

Order No.	Model	Spec.	W	L	L1	t	Pitch	L2	H	N.W.
54230-02	407E	100X175	100	175	139	20	2+4	191	50	7.00kg
54230-04	510E	125X250	125	250	212			266		13.9kg
54230-06	612E	150X300	150	300	256			316		17.5kg
54230-08	614E	150X350	150	350	306			366		22.5kg
54230-09	616E	150X400	150	400	356			416		25.9kg
54230-10	618E	150X450	150	450	400			466		28.2kg
54230-12	816E	200X400	200	400	356			416		32.5kg
54230-14	818E	200X450	200	450	400			466		35.7kg
54230-16	820E	200X500	200	500	450			516		42.0kg

MAGNETIC TOOLS

**54240** V Micropitch Permanent Magnetic Chuck



**Features :**

- ▶ Suitable for surface grinding and EDM machines.
- ▶ Suitable for holding small and thin workpieces.
- ▶ Overall sealed water resistance.
- ▶ High precision with strong magnetic force up to 14 kgf/cm<sup>2</sup>.
- ▶ Thicker top plate is applied, extended lifecycle.
- ▶ Strong mag. force with high accuracy.

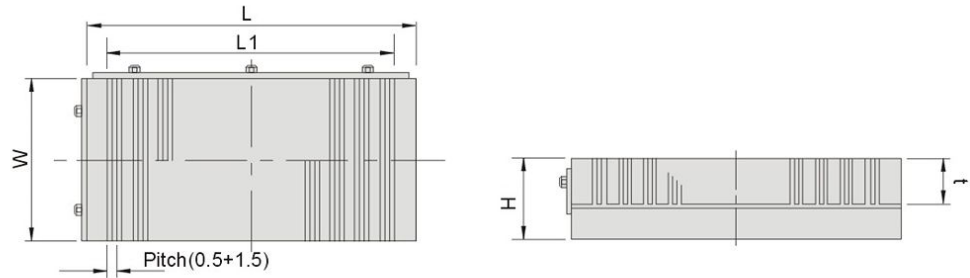

MAGNETIC TOOLS

Unit:mm

Order No.	Model	Spec.	W	L	L1	t	Pitch	H	N.W.
54240-02	407V	100X175	100	175	139	20	0.5+1.5	52	7.5kg
54240-04	606V	150X150	150	150	114			52	9.7kg
54240-06	510V	125X250	125	250	212			52	13kg
54240-08	612V	150X300	150	300	256			60	21kg
54240-10	614V	150X350	150	350	306			60	25.8kg
54240-11	616V	150X400	150	400	356			60	32.6kg
54240-12	618V	150X450	150	450	400			60	32.2kg
54240-14	816V	200X400	200	400	356			60	39.0kg
54240-16	818V	200X450	200	450	400			60	40.5kg
54240-18	820V	200X500	200	500	450			60	47.7kg



# Magnetic Chuck

## 54250 W Powerful Micropitch Permanent Magnetic Chuck



### Features :

- ▶ Suitable for surface grinding and EDM machines.
- ▶ Suitable for holding small and thin workpieces thanks its ideally designed pole pitch.
- ▶ While turning magnetic force ON/OFF, the flat face's accuracy remain the same and keep high precision processing surface.
- ▶ Copper welding protects faceplate from cutting fluid corrosion.
- ▶ Made of permanent magnet, with strong attraction and less residual magnetism.

MAGNETIC TOOLS

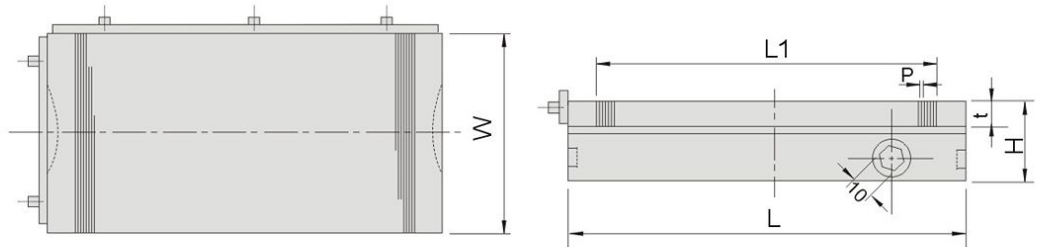

Unit:mm

Order No.	Model	Spec.	W	L	L1	t	Pitch	H	N.W.
54250-02	407W	100X175	100	175	125	18	Copper 2 (1+1)	52	7.7kg
54250-04	606W	150X150	150	150	110				10.0kg
54250-06	510W	125X250	125	250	205				13.9kg
54250-08	612W	150X300	150	300	246			58	22.3kg
54250-10	614W	150X350		350	296				25.4kg
54250-12	618W	150X450		450	390				34.0kg
54250-14	816W	200X400	200	400	346				38.4kg
54250-16	818W	200X450		450	390				45.0kg
54250-18	820W	200X500		500	446				48.3kg

**54260** VW Powerful Micropitch Permanent Magnetic Chuck



**Features :**

- ▶ Suitable for surface grinding and EDM machines.
- ▶ The fine-pitched magnetic poles make it ideally suitable for small and thin workpieces, specially designed for high precision operation.
- ▶ Brazing treatment protects the top plate from coolant corrosion.
- ▶ Strong holding power, residual magnetism reduced.
- ▶ Stainless steel pole pitch adopted for the top plate.
- ▶ Excellent water resistant, enables to be used in liquid.
- ▶ ON/OFF switching doesn't influence plate flatness accuracy.

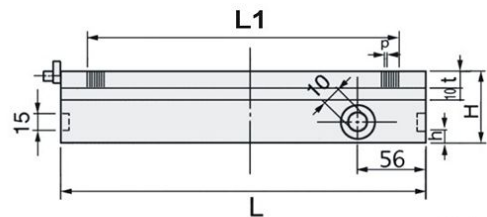
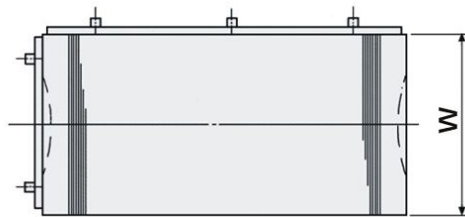

Unit:mm

Order No.	Model	Spec.	W	L	L1	t	Pitch	H	N.W.
54260-01	305VW	75x130	75	130	85	18	stainless steel 1.4 (0.4+1)	58	4.0kg
54260-02	307VW	75x175		175	125				5.5kg
54260-03	312VW	75x300		300	246			9.0kg	
54260-04	407VW	100x175	100	175	125			52	7.0kg
54260-05	510VW	125x250	125	250	205				12.0kg
54260-06	606VW	150X150	150	150	110				9.0kg
54260-07	612VW	150x300		300	246			20.0kg	
54260-08	614VW	150x350		350	296			24.0kg	
54260-09	616VW	150x400		400	346			27.5kg	
54260-10	618VW	150x450	200	450	390			58	31.0kg
54260-11	816VW	200x400		400	346				37.0kg
54260-12	818VW	200x450		450	390				41.5kg



# Magnetic Chuck

**54300** U Rotary Permanent Magnetic Chuck

**54310** UW Rotary Micropitch Permanent Magnetic Chuck

U



## Features :

- ▶ Suitable for angular grinding on surface grinder.
- ▶ Scale reading on the rotary shaft is easily read for angle setup.
- ▶ Accuracy remained during switch ON/OFF changeover.
- ▶ TWO Pole pitch types could be chosen.

UW



Vernier Scale



90° demo

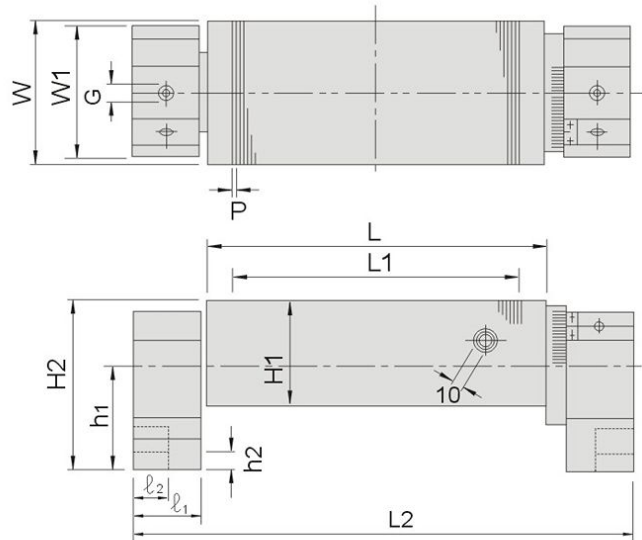

Unit:mm

Order No.	Model	Spec.	W	L	L1	H1	Pitch	L2	W1	ℓ1	ℓ2	G	h1	h2	H2	N.W.
54300-07	407U	100X175	100	175	125	78	11.2 (1.6+2+1.6+6)	293	100	50	25	14	103	15	145	19kg
54300-10	510U	125X250	125	250	200			368								29.5kg
54300-12	612U	150X300	150	300	246			418								38.0kg
54300-14	614U	150X350	150	350	296			468								42.0kg
54300-18	618U	150X450	150	450	396			568								52.0kg

Unit:mm

Order No.	Model	Spec.	W	L	L1	H1	Pitch	L2	W1	ℓ1	ℓ2	G	h1	h2	H2	N.W.
54310-07	407UW	100X175	100	175	125	78	2 (1+1)	293	100	50	25	14	103	15	145	21.0kg
54310-10	510UW	125X250	125	250	200			368								30.0kg
54310-12	612UW	150X300	150	300	246			418								38.5kg
54310-14	614UW	150X350	150	350	296			468								42.5kg
54310-18	618UW	150X450	150	450	396			568								52.5kg



**54320 RD Precision Adjustment Rotary Magnetic Chuck**

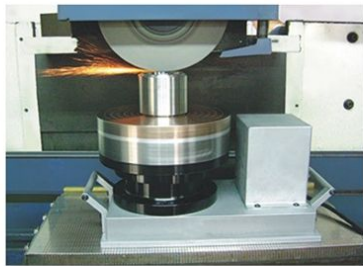

**Features :**

- ▶ Suitable for surface grinders, easy to install and disassemble.
- ▶ Rotary grinding is suitable for machining spindle spacer rings, circular workpieces or gaskets.
- ▶ Rotary grinding can achieve high efficiency and increase cost effectiveness than traditional method.
- ▶ According to the size of the workpiece, the rotation speed can be changed even while operating.
- ▶ Rotation accuracy within 0.001mm
- ▶ Adopting high quality bearings in structure to ensure precision spindle and durability.
- ▶ Adopting speed control motor of Oriental Motor, precise, smooth and durable.
- ▶ IP55 water resistance, prevent from damp and increase lifecycle.
- ▶ 90W ~ 400W speed control motor.
- ▶ Magnetic Chuck surface flatness within 0.002mm.
- ▶ Rotary loading speed variation rate is within  $\pm 2\%$
- ▶ Voltage: 110v / 220v 50/60Hz

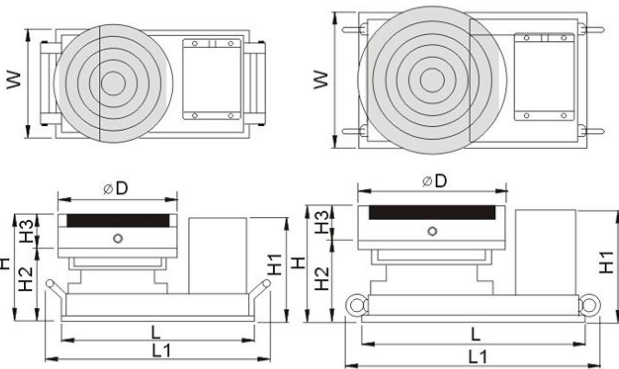

RD130 RD160 RD200 RD250 RD300 RD400

Unit:mm

Order No.	Model	L	L1	W	H	H1	H2	H3	ØD	Volts IPH	Motor Ratio	R.P.M /min	Mass Kg/cm <sup>2</sup>	Load	N.W.
54320-02	RD130-110	265	328	130	166	148	114	52	130	110V	60W 1:10	50-300	2.8	10kg	23kg
54320-04	RD130-220	265	328	130	166	148	114	52	130	220V	60W 1:10	50-300	3.0	12kg	23kg
54320-06	RD160-110	280	335	138	156	144	98	58	160	110V	65W 1:15	15-150	10	15kg	25kg
54320-08	RD160-220	280	335	138	156	144	98	58	160	220V	65W 1:15	15-150	10	15kg	25kg
54320-10	RD200-110	325	372	172	174	162	116	58	200	110V	75W 1:20	15-150	18	22kg	46kg
54320-12	RD200-220	325	372	172	174	162	116	58	200	220V	75W 1:20	15-150	18	22kg	46kg
54320-14	RD250-220	376	448	218	186	183	128	58	250	220V	120W 1:20	15-150	24	30kg	65kg
54320-16	RD300-220	424	495	244	196	186	138	58	300	220V	200W 1:25	12-125	112	36kg	86kg
54320-18	RD400-220	540	636	342	228	220	168	60	400	220V	400W 1:25	12-125	160	50kg	155kg

MAGNETIC TOOLS

# Magnetic Chuck

## 54330 FCD Round Fine Pitch Permanent Magnetic Chuck



### Features :

- ▶ Suitable for surface grinding machine.
- ▶ Suitable for holding Small workpieces.
- ▶ Overall sealed water resistance.
- ▶ High precision with strong magnetic force up to 13 kgf/cm<sup>2</sup>.

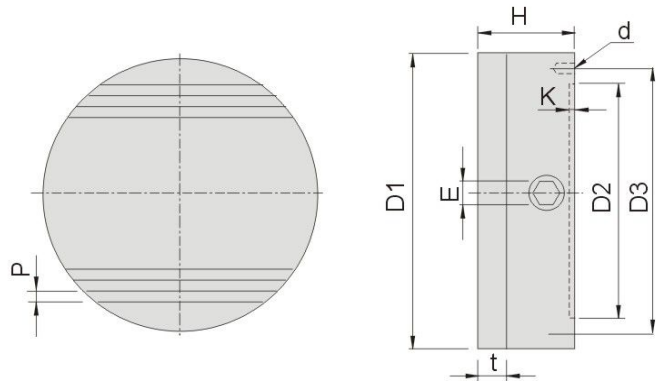

MAGNETIC TOOLS

Unit:mm

Order No.	Model	D1	t	Pitch	D2	D3	K	d	E	H	N.W.
54330-100	FCD100	100	10	4 (1+3)	60	85	4	4-M6	8	52	3.15kg
54330-130	FCD130	130			90	115	4	4-M8			4.9kg
54330-150	FCD150	150			110	132	4				6.7kg
54330-160	FCD160	160			120	140	4	7.7kg			
54330-200	FCD200	200			160	180	5	4-M10			12.5kg
54330-250	FCD250	250			200	225	5				19.5kg
54330-300	FCD300	300			230	280	5				28.5kg
54330-350	FCD350	350			230	311	5				39kg
54330-405	FCD405	405			230	380	5	52kg			

**54340** MCD >> Round Micro Pitch Permanent Magnetic Chuck



**Features :**

- ▶ Suitable for surface grinding machine.
- ▶ Suitable for holding Small workpieces.
- ▶ Overall sealed water resistance.
- ▶ High precision with strong magnetic force up to 13 kgf/cm<sup>2</sup>.

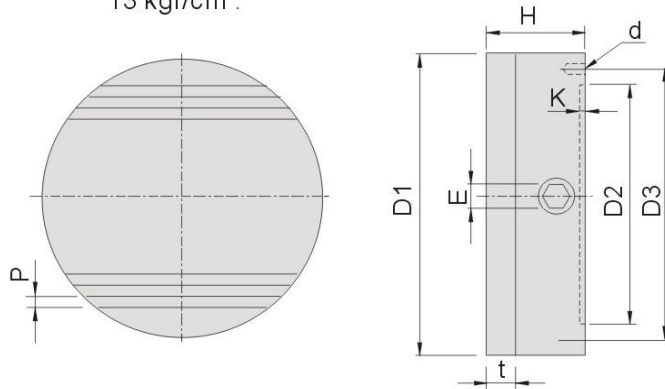

Unit:mm

Order No.	Model	D1	t	Pitch	D2	D3	K	d	E	H	N.W.
54340-100	MCD100	100	10	0.5+1.5	60	85	4	4-M6	8	52	3.1kg
54340-130	MCD130	130			90	115	4	4-M8			4.7kg
54340-150	MCD150	150			110	132	4				6.7kg
54340-160	MCD160	160			120	140	4	4-M10			7.6kg
54340-200	MCD200	200			160	180	5				11.6kg
54340-250	MCD250	250			200	225	5				17.8kg
54340-300	MCD300	300			230	280	5	4-M10			29.0kg
54340-350	MCD350	350			230	311	5				39.0kg
54340-405	MCD405	405			230	380	5				52.0kg



# Magnetic Chuck

**54350** HMTR Powerful Circular Type Permanent Magnetic Chuck



### Features :

- ▶ Suitable for Lathe, 4<sup>th</sup> axis CNC and cylindrical grinder.
- ▶ Suitable for holding workpieces of special alloy material such as Tungsten.
- ▶ Special design with ON/OFF structure, superb performance.
- ▶ High precision with strong magnetic force up to 3 times than general magnetic chuck.
- ▶ Wrench apply 360° rotary.

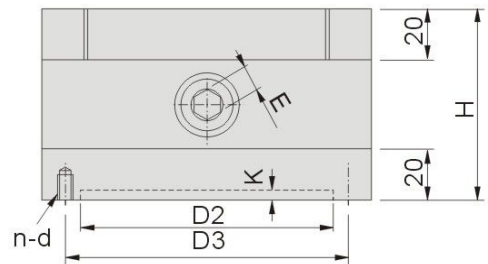
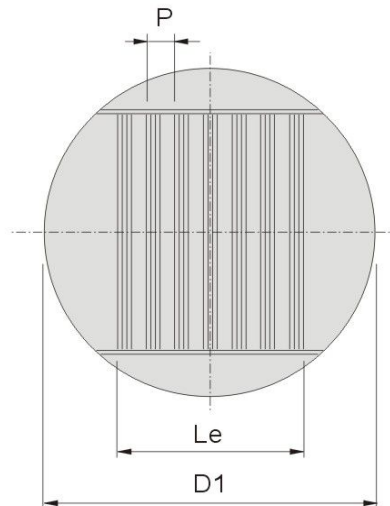

Unit:mm

Order No.	Model	D1	Le	Pitch	D2	D3	K	n-d	E	H	N.W.
54350-13	HMTR-13	130	78	11.2 (1.6+2+ 1.6+6)	100	112	4	4xM6	10	80	6.5kg
54350-16	HMTR-16	160	100		125	140	4	4xM8			9.8kg
54350-20	HMTR-20	200	128		160	180	4	4xM8			15kg

**54360** HRCS >> Round Star-pole Type Permanent Magnetic Chuck

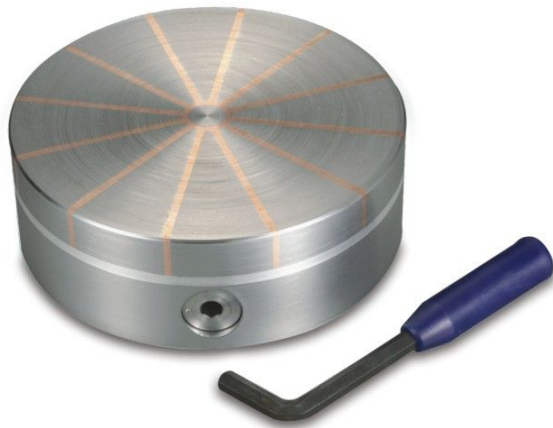

**Features :**

- ▶ Suitable for Lathe, Milling, Rotary grinding machines...tc.
- ▶ Powerful and well spread magnetic force, stable and no distortion.
- ▶ Durable and wear-resistance design with great water resistance.

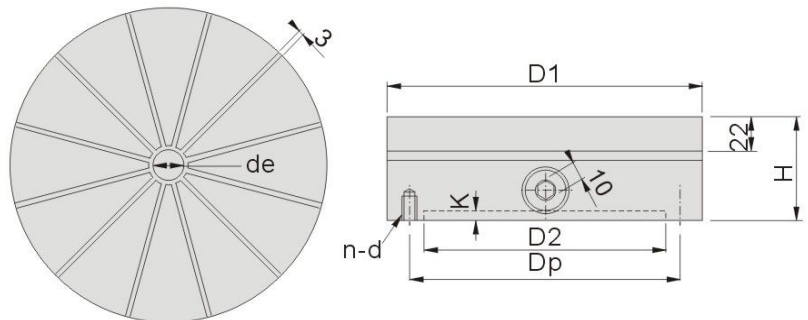

MAGNETIC TOOLS

Unit:mm

Order No.	Model	D1	de	Pole q'ty	D2	K	n	d	Dp	H	N.W.
54360-02	HRCS-10	104	16	8	63	4	M6	4	80	65	4.2kg
54360-04	HRCS-13	130		12	80		M8		112		6.6kg
54360-06	HRCS-16	162		125	140				10.2kg		
54360-08	HRCS-20	202	19	16	160		M10		180	70	17.1kg
54360-10	HRCS-25	250		200	224				26.2kg		
54360-12	HRCS-32	320	24	250	280				43.2kg		
54360-14	HRCS-36	360	40	30	280		M12		320	80	55.0kg
54360-16	HRCS-40	400	46	36	315				355		67.0kg

# Magnetic Chuck

**54500**

PMCA

Powerful Permanent Magnetic Chuck (GRID)



## Features :

- ▶ Suitable for CNC machining center, no need power plug-in and no overheated problem when using for a long time.
- ▶ High accuracy for the PMCA chuck which keeps 0.005/100mm and thus ensure the processing result for the workpiece.
- ▶ Unique magnetic circuit design for exceptionally strong and uniform suction, High-performance high-quality magnetic steel suction can reach 20 Kg/cm<sup>2</sup> or higher.

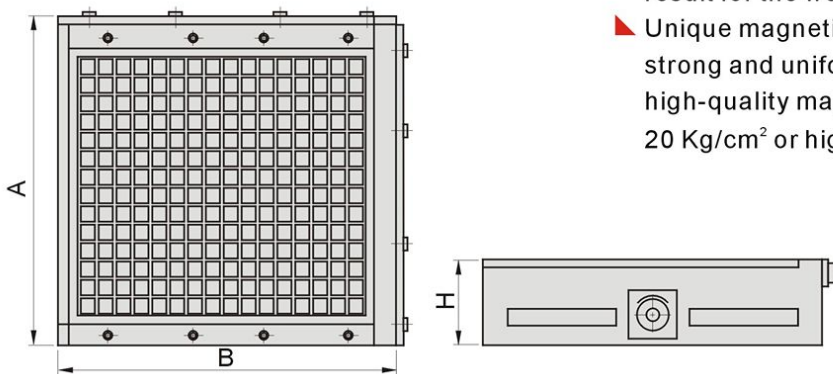

單位:mm

Order No.	Model	A	B	H	Square Pole Size	Pole qty.	Mag.Force (KN)	N.W.
54500-01	PMCA1530	150	300	60	12x12	120	>12	27kg
54500-02	PMCA2030	200	300	60		165	>18	36kg
54500-03	PMCA2040	200	400	72	18x18	120	>22	30kg
54500-05	PMCA3030	300	300	90		132	>25.6	52kg
54500-06	PMCA3030S	300	300	72		132	>25.6	40kg
54500-07	PMCA3040	300	400	90		180	>35	67kg
54500-08	PMCA3040S	300	400	72		180	>35	45kg
54500-09	PMCA4040	400	400	90		240	>46.6	85kg
54500-10	PMCA4050	400	500	90		300	>58.2	100kg
54500-11	PMCA4060	400	600	90		360	>69.8	120kg
54500-12	PMCA4070	400	700	77		464	>82.4	130kg
54500-13	PMCA4080	400	800	110		480	>93	171kg
54500-14	PMCA5060	500	600	90	456	>83.8	155kg	
54500-15	PMCA5070	500	700	77	580	>99.7	160kg	
54500-16	PMCA5080	500	800	77	660	>115.7	200kg	



**54540** PMC Powerful Permanent Magnetic Chuck (GRID)

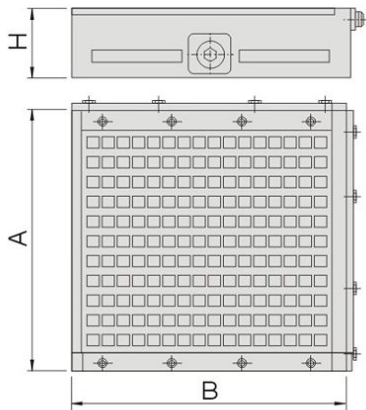

**Features :**

- ▲ Fulfill the high precision and efficiency required by machining center, CNC milling machines
- ▲ With superb loading efficiency which saves almost 80% time, and stable magnetic force can even hold workpiece which larger than itself and realise 5 sides processing
- ▲ Square poles combination with density and powerful force, high precision workpieces can be achieved while inner stress during processing.
- ▲ Powerful attraction can hold least thickness 2mm above for processing.
- ▲ Environmental safe and simple operation.



Unit:mm

Order No.	Model	A	B	H	Square Pole Size	Pole qty.	Mag.Force (KN)	N.W.
54540-02	PMC-2040	200	400	72	18x18	120	>25	56kg
54540-04	PMC-3040	300	420	72		180	>35	65kg
54540-06	PMC-3030	300	300	92		132	>25.6	50kg
54540-08	PMC-4040	400	400	92		240	>46.6	84kg
54540-10	PMC-4050	400	500	92		300	>58.2	100kg
54540-12	PMC-3060	300	600	92		264	>55	94kg
54540-14	PMC-3040A	300	400	92		176	>34.1	65kg
54540-16	PMC-5050	500	500	92		400	>77.6	125kg
54540-18	PMC-4060	400	600	92		360	>69.8	118kg
54540-20	PMC-4080	400	800	112		480	>93	161kg
54540-22	PMC-50100	500	1000	112		800	> 155.2	260kg

# Magnetic Chuck

## 54550 EPM-B Standard Type Electro-Permanent Magnetic Chuck



LxWxH:330x300x120mm

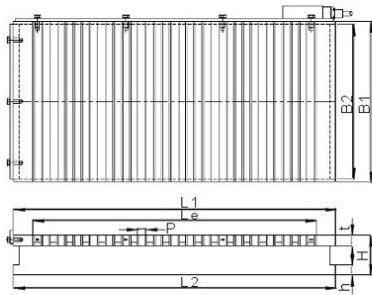

### Features :

- ▶ Suitable for light and long period processing. 1.5 seconds for switch ON and OFF, increase efficiency.
- ▶ Magnetic density up to 1300 gauss with light weight design which greatly reduce mechanical wear.
- ▶ No electricity capacity, power off after attraction can still remain attraction, eco and no heat generated. Distortion free and lead high precision and long lifecycle.
- ▶ Brazing top plate with excellent water resistant & high insulation resistance.
- ▶ Effective for thin and small workpieces applied

MAGNETIC TOOLS

Order No.	Model	Spec.	B1	L1	Le	t	Pitch	B2	L2	h	H	N.W.
54550-02	EPM-1530B	150X300	150	300	258	20	15(3+12)	146	300	20	75	20kg
54550-04	EPM-1535B	150X350		350	288				350			24kg
54550-06	EPM-1540B	150X400		400	348				400			28kg
54550-08	EPM-1545B	150X450		450	408				450			30kg
54550-10	EPM-2040B	200X400	200	400	348	25	19(3+16)	196	400	20	95	38kg
54550-12	EPM-2045B	200X450		450	408				450			41kg
54550-14	EPM-2050B	200X500		500	438				500			45kg
54550-16	EPM-2550B	250X500	250	500	438	25	19(3+16)	240	20	95	65kg	
54550-18	EPM-3060B	300X600	300	600	528			290			600	81kg
54550-20	EPM-4080B	400X800	400	800	744			390			800	195kg
54550-22	EPM-40100B	400X1000		1000	934	1000	245kg					
54550-24	EPM-50100B	500X1000	500	1000	934	25	19(3+16)	490	20	95	305kg	
54550-26	EPM-50150B	500X1500		1500	1428						1500	457kg
54550-28	EPM-60100B	600X1000	600	1000	934	25	19(3+16)	590	20	95	366kg	
54550-30	EPM-60150B	600X1500		1500	1428						1500	550kg

Unit:mm

# 54560 EPM-E Super Powerful Electro-Permanent Magnetic Chuck



LxWxH:330x300x120mm

### Features :

- ▶ Suitable for CNC machining center, Double-column Machining center or NC milling machine.
- ▶ Magnetic density up to 4000 gauss with light weight design which greatly reduce mechanical wear.
- ▶ Brazing top plate with excellent water resistant & high insulation resistance.
- ▶ Magnetic force beyond 18 Kgf/cm<sup>2</sup> averagely

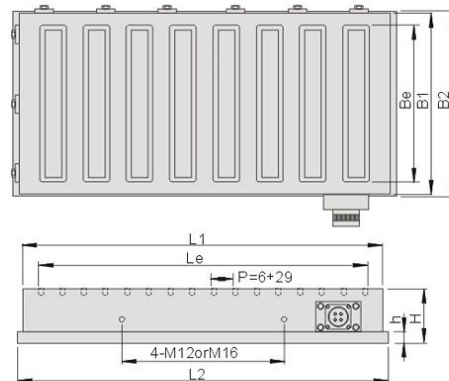

Order No.	Model	Spec.	B1	Be	L1	Le	Pitch	B2	L2	h	H	N.W.
54560-02	EPM-2050E	200X520	200	164	520	486	35 (6+29)	204	540	19	85	62kg
54560-04	EPM-2550E	250X520	250	214				254	540			78kg
54560-06	EPM-3060E	300X600	300	260	600	571		304	620			108kg
54560-08	EPM-4040E	400X400	400	360	400	352		404	420			96kg
54560-10	EPM-4050E	400X520			520	486			540			120kg
54560-12	EPM-4080E	400X810			810	770			830			192kg
54560-14	EPM-40100E	400X1000			1000	948			1020			240kg
54560-16	EPM-5050E	500X520	500	460	520	486		504	540			150kg
54560-18	EPM-50100E	500X1000			1000	948			1020			300kg
54560-20	EPM-50150E	500X1500			1500	1447			1520			450kg
54560-22	EPM-6060E	600X600			600	571	620		216kg			
54560-24	EPM-60100E	600X1000	600	560	1000	948	604	1020	360kg			
54560-26	EPM-60150E	600X1500			1500	1447		1520	540kg			

Unit:mm





# Magnetic Chuck

## 54600 EPM Electro-control Permanent Magnetic Chuck

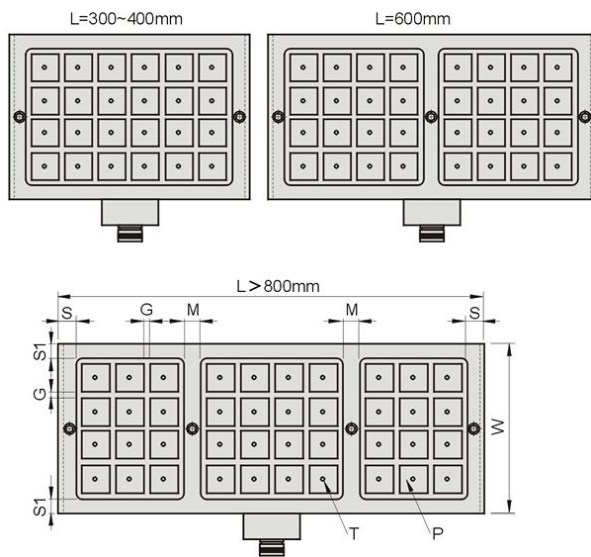

### Features :

- ▶ Eletro-control Permanent magnetic chuck structure design: 1~6 seconds charging and demagnetization, built-in permanent magnet (NdFeB) No need for continuous power supply, no temperature rise, no deformation and keep processing accuracy.
- ▶ With application of Spring Block, 5-faces processing can be done with drill, tapping, milling, increase work efficiency and improve repeating accuracy.
- ▶ Suitable for small & medium size workpiece and rough, drilling and fine processing, min. Thickness required at least 10mm.
- ▶ Best application is that at least 4 poles contact with worpieces.
- ▶ With application of Fixed Block, irregular and surface bending workpieces can be clamped for processing.
- ▶ Magnetic force up to 1250KG ± 5%/100mm<sup>2</sup>.
- ▶ Voltage : AC 220V / 1PH

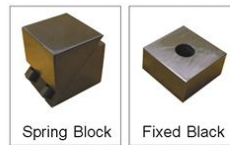

Please use the triangle as the basis point when installing the fixed blocks.

Unit:mm

Order No.	Model	W	L	M	S	S1	T	Height	G	P	Pole Qty	Current AMP	N.W.	
													Controller	Magnetic
54600-02	EPM2540W	240	430	--							18	18A		50kg
54600-04	EPM2560W	240	590	30							24	30A		69kg
54600-06	EPM2580W	240	810	30							33	30A		92kg
54600-08	EPM2590W	240	870	30							36	18A		98kg
54600-10	EPM25100W	240	990	30							42	26A		111kg
54600-12	EPM3030W	300	310	--							16	20A		44kg
54600-14	EPM3040W	300	430	--							24	30A		61kg
54600-16	EPM3060W	300	590	30							32	30A		82kg
54600-18	EPM3080W	300	810	30							44	25A		116kg
54600-20	EPM3090W	300	870	30							48	30A		123kg
54600-22	EPM30100W	300	990	30							56	35A		138kg
54600-24	EPM4040W	420	430	--							36	18A		84kg
54600-26	EPM4050W	420	490	--	30	25	M8	60	Pitch 10	50x50	42	26A	12kg	95kg
54600-28	EPM4060W	420	590	30							48	30A		100kg
54600-30	EPM4080W	420	810	30							66	30A		159kg
54600-32	EPM4090W	420	870	30							72	18A		169kg
54600-34	EPM40100W	420	990	30							84	26A		193kg
54600-36	EPM5060W	480	590	30							56	35A		129kg
54600-38	EPM5080W	480	810	30							77	30A		185kg
54600-40	EPM5090W	480	870	30							84	26A		196kg
54600-42	EPM50100W	480	990	30							98	30A		219kg
54600-44	EPM6060W	600	590	30							72	18A		165kg
54600-46	EPM6080W	600	810	30							99	30A		215kg
54600-48	EPM6090W	600	870	30							108	27A		240kg
54600-50	EPM60100W	600	990	30							126	32A		274kg
54600-52	EPM8080W	755	810	30							121	33A		271kg

MAGNETIC TOOLS

**54600** EPM >> **Electro-control Permanent Magnetic Chuck**

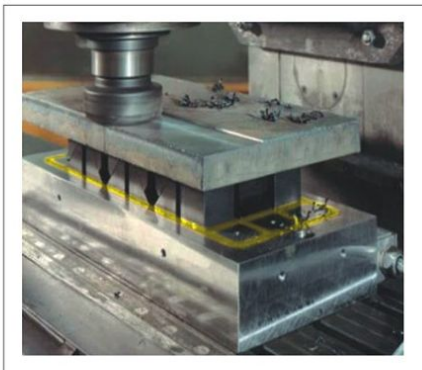
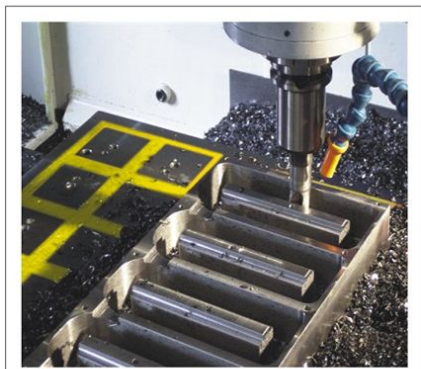
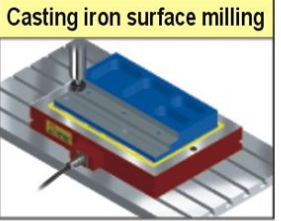
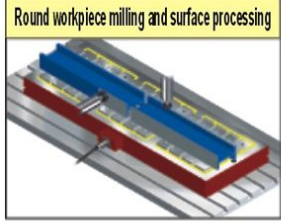
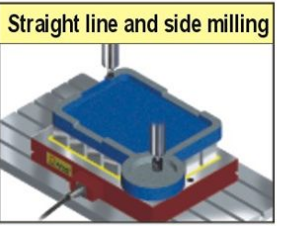
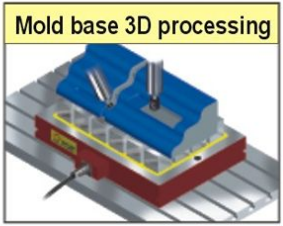
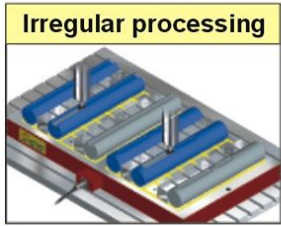
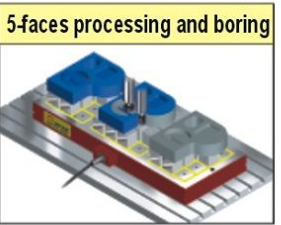
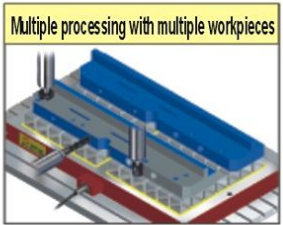
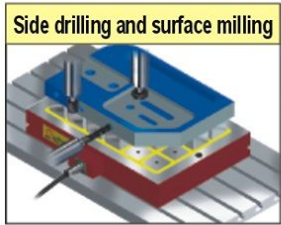
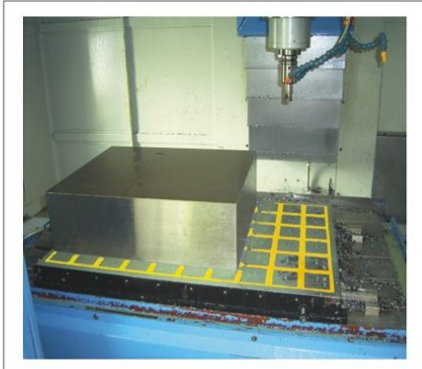

MAGNETIC TOOLS



# Magnetic Chuck

**54610**

VLC

Vacuum Chuck

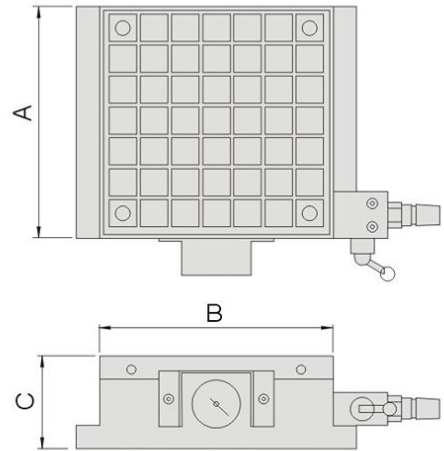

## Features :

### 1.No pump needed

Vacuum ejector and can operate simply through compressor. Vacuum Chuck can discharge cooling oil. Cooling water or rubbish etc... even machine had inhaled.

### 2.Perfect performance on any types of workpieces

Perform well with surface and side processing as well as grinding processing. With application of metal plate, it can achieve side processing and even drilling.

### 3.Flexibility size

Depending on the workpieces' size, this product is flexible to setup bases.

### 4.Key bottom & Work stabilizer

Key bottom at the base bottom to ensure parallel and squareness when apply parallel. Avoiding horizontal pressure by setting up work stabilizer at side.

### 5.Suitable application

Light metal, heavy metal and iron borad.

Plastic products, ceramics, glass, stainless, aluminum, wood, stone, all non-magnetic products and non-ventilation smooth products.

Small, flat surface but need complicated work.

Need overall processing workpieces but nowhere effectively clamped.

Workpiece that don't want to leave surface scratches, distortion when processing.

Workpiece that is super thin and no where to clamp

Workpiece that is Irregular shape and surface smooth

- Parallelism:0.015mm/100mm

- Material: S55C

- Product: black oxide & top & bottom ground

- Character: airblow circuit to conceal

- Plate: heat treatment

- Accessory: silicone  $\varnothing$ 4x 2 meter

Unit:mm

Order No.	Model	A	B	C	Air Consumption	Max. Suction	N.W.
54610-01	VLC-1515	150	150	50	23 l/min	12 l/min	9.2kg
54610-02	VLC-1530	150	300	50	23 l/min	12 l/min	13.7kg
54610-03	VLC-2020	200	200	50	46 l/min	24 l/min	12.1kg
54610-04	VLC-2040	200	400	100	46 l/min	24 l/min	22.2kg
54610-05	VLC-2525	250	250	100	78 l/min	40 l/min	16.4kg
54610-06	VLC-2550	250	500	100	78 l/min	40 l/min	30.6kg
54610-07	VLC-3030	300	300	100	23 l/min	12 l/min	23.4kg
54610-08	VLC-3045	300	450	100	46 l/min	24 l/min	37.0kg
54610-09	VLC-3060	300	800	100	46 l/min	24 l/min	48.8kg
54610-10	VLC-3075	300	750	100	46 l/min	24 l/min	50.4kg
54610-11	VLC-4040	400	400	100	46 l/min	24 l/min	42.5kg
54610-12	VLC-4060	400	600	100	92 l/min	48 l/min	82.7kg
54610-13	VLC-4080	400	800	100	92 l/min	48 l/min	72.9kg
54610-14	VLC-40100	400	1000	100	92 l/min	48 l/min	103.1kg
54610-15	VLC-5050	500	500	100	78 l/min	10 l/min	59.2kg
54610-16	VLC-5075	500	750	100	15 l/min	80 l/min	87.8kg
54610-17	VLC-50100	500	1000	100	15 l/min	80 l/min	116.4kg
54610-18	VLC-50125	500	1250	100	15 l/min	80 l/min	145.0kg
54610-19	VLC-6060	600	600	100	78 l/min	40 l/min	78.8kg
54610-20	VLC-6090	600	900	100	15 l/min	80 l/min	116.4kg

1)If the workpiece is high adhesive and made of soft material, chips may malt on the cutter. It is suggested that Coolant fluid is suggested applying steadily on the cutter.

2)Workpiece must be larger than the O ring applied, or it would not be properly attracted.



**54610** VLC Vacuum Chuck

Start operation right away as combine

None magnesium alloy



MAGNETIC TOOLS

The chuck apply for milling machining or grinding machine to process the surface and side

Features	
1	Change the chuck's size depend on the workpiece's size
2	No need air pump, just connect the air compressor then start the operation
3	Any workpiece can be done very well
Suitable Material	
Light metal, hard metal, plastics, ceramics, glass, aluminum alloy, stainless steel...etc none paramagnet and no ventilated plane.	

Using approach	
Use semi-automatic milling machine to process	
Notices	
1	Use air pressure to suction the workpiece and make operation
2	The air pressure should match the workpiece's size and get the max inhaled square measure
3	Air supplier should be stable
4	Check Seal's condition and whether the material airtight
5	The inhaled square measure and ventilation of workpiece
6	Temperature, humidity and curved extent

※workpiece has to over the size of the sillcon or can not be inhaled

# Magnetic Chuck

## 54620 GLM Permanent Lifting Magnetic

GLM100



GLM300



GLM600



GLM1000



GLM2000



GLM3000

### Features :

- ▶ **Safety**  
 Lifting magnetic ensure the stable magnetic force and tested to hold 3.5 TIMES, the rated load for maximum safety.
- ▶ **Rigidity**  
 Adopting steel block and machined by CNC and FNC system for ensure accuracy and rigidity.
- ▶ **Durability**  
 Nickel-plating on all parts of steel to increase lifecycle, enhance surface hardness on all poles to ensure the best operation condition, maintenance free.
- ▶ It's perfect for loading or unloading most workpieces including press molds, plastic molds, machined parts, etc...
- ▶ Apply this lifting magnetic to move plate steel, block or round steel, and iron material in your factory.
- ▶ Permanent magnetic requires no electricity to perform material lifting.
- ▶ Safety factor tested hold up to 3.5 times.
- ▶ Fast, safe & efficient material lifting, loading and unloading.

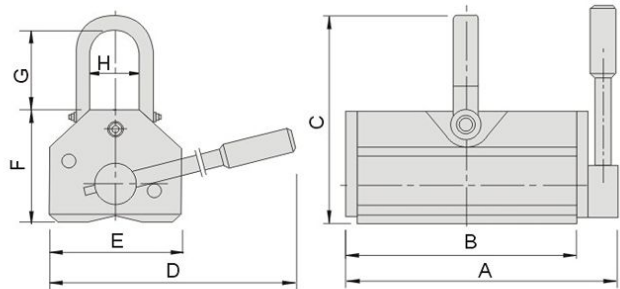

Unit:mm

Order No.	Model	Capacity (kg)	A	B	C	D	E	F	G	H	Safety factor	N.W.
54620-02	GLM100	100	107	84	129	123	60	71	46	30	x3.5	2.5kg
54620-04	GLM300	300	180	155	157	185	90	93	51	41		8.6kg
54620-06	GLM600	600	255	224	213	263	115	120	77	52		21kg
54620-08	GLM1000	1000	294	259	286	377	163	169	97	87		46kg
54620-10	GLM2000	2000	422	380	355	515	216	215	105	123		118kg
54620-12	GLM3000	3000	587	521	423	710	216	232	158	80	x3.0	181kg

MAGNETIC TOOLS



## Applications

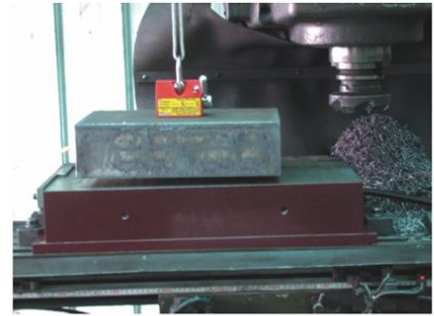

MAGNETIC TOOLS

**Instruction**  
NO/OFF switch, easy and fast as

**ON**



**OFF**

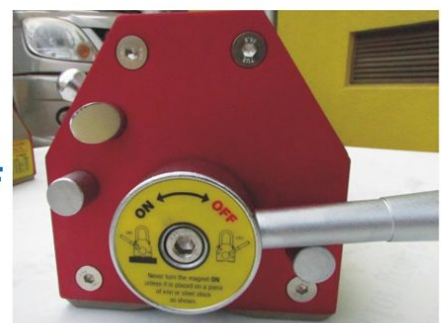

**Caution:**  
Lever in the "ON" position. Note the safety lock is engaged on the lifting magnetic.



# Magnetic Tools

## 54810 HD010 Bar Type Demagnetizer

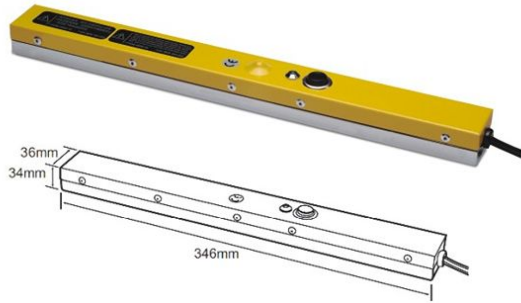

### Features :

- ▶ Demagnetizing press die, plastic mold, large plate steel... etc
- ▶ Portable and easy to operate
- ▶ Demagnetizing simple and fast, no need to unloading mold from machine.
- ▶ Less chips left on mold and increase the lifecycle.



Unit:mm

Order No.	Model	Voltage	Current	Usage interval	N.W.
54810-110	HD010	AC110V 1PH	1.1A	4 min.stop for 1 min.usage	1.1 kg
54810-220	HD010	AC220V 1PH	0.5A		1.1 kg

MAGNETIC TOOLS

## 54816 HD030 Circular Type Demagnetizer

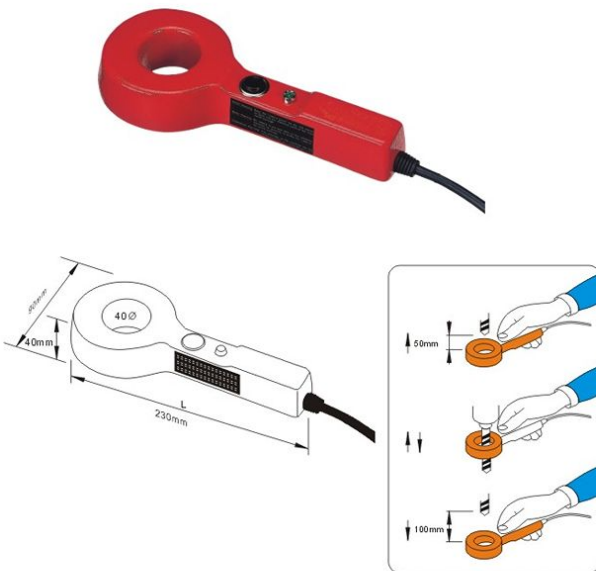

### Features :

- ▶ Demagnetizing drill, cutting tool, cutter and other tools such as slide calipers.
- ▶ Demagnetizing with tools installed on machine with no problem.
- ▶ Temperature protection; electrifying for 1 min. and pausing for 4 mins.
- ▶ Portable and easy to operate.
- ▶ Adopting aluminum to form body for rigid and durable.

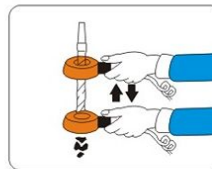

Unit:mm

Order No.	Model	Voltage	Current	Usage interval	Capacity ∅	N.W.
54816-110	HD030	AC110V 1PH	0.85A	4 min.stop for 1 min.usage	∅	0.85kg
54816-220	HD030	AC220V 1PH	0.3A		∅40	0.85kg

**54820** HD123 >> Handy Type Demagnetizer

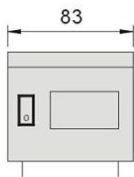
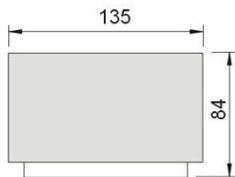
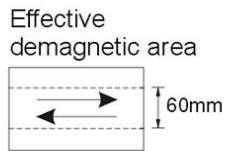

**Features :**

- ▶ Demagnetizing plate steel, mold, tools etc...
- ▶ Portable and easy to operate, light weight.
- ▶ Automatic temp. protection: power cut when reach the certain setting point, it restart to work once cool down.

Order No.	Model	Voltage	Current	Usage interval	N.W.
54820-110	HD123	AC110V 1PH	0.9A	10 min.stop for 20 min.usage	1.65kg
54820-220	HD123	AC220V 1PH	0.3A		1.65kg

Unit:mm

**54822** HD180 >> Plate Type Demagnetizer

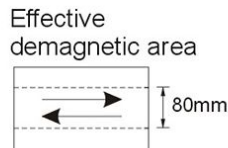

**Features :**

- ▶ Demagnetizing general parts, accessories and tools etc...
- ▶ Automatic temp. protection: power cut when reach the certain setting point, it restart to work once cool down.

Order No.	Model	Voltage	Current	Usage interval	N.W.
54822-110	HD180	AC110V 1PH	2.6A	10 min.stop for 20 min.usage	4kg
54822-220	HD180	AC220V 1PH	1.3A		4kg

Unit:mm

**54824** HD200 >> Standard Type Demagnetizer

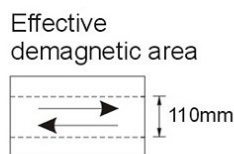

**Features :**

- ▶ Demagnetizing general parts, accessories and tools etc...
- ▶ Suitable for long period usage.

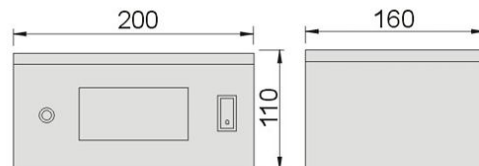

Order No.	Model	Voltage	Current	Usage interval	N.W.
54824-110	HD200	AC110V 1PH	2.4A	5 min.stop for 60 min.usage	7.0kg
54824-220	HD200	AC220V 1PH	1.3A		7.0kg

Unit:mm

# Magnetic Tools

## 54826 HD280 Powerful Type Demagnetizer



### Features :

- ▶ Demagnetizing plate steel, large mold, tools etc...
- ▶ Big effective demagnetizing range: 160mm
- ▶ Suitable for material such as high carbon steel, mold steel etc... which are difficult to be demagnetized.
- ▶ Suitable for long period usage.

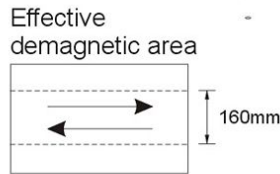
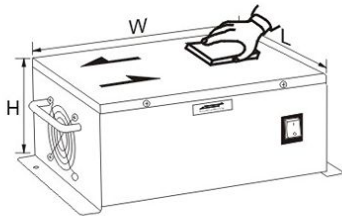

Unit:mm

Order No.	Model	Voltage	Current	Usage interval	L	W	H	N.W.
54826-110	HD280	AC 110V 1PH	6.4A	5 min.stop for 60 min.usage	225	340	125	15.0kg
54826-220	HD280	AC 220V 1PH	3.2A		225	340	125	15.0kg

MAGNETIC TOOLS

## 54828 HD380 Powerful Type Demagnetizer



### Features :

- ▶ Demagnetizing plate steel, large mold, tools etc...
- ▶ Big effective demagnetizing range: 160mm
- ▶ Suitable for long period usage.

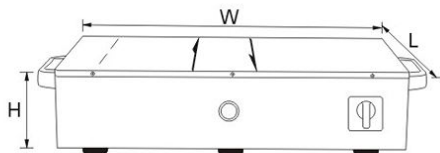

Unit:mm

Order No.	Model	Voltage	Current	Usage interval	L	W	H	N.W.
54828-110	HD380	AC 110V 1PH	12.8A	5 min.stop for 60 min.usage	275	485	135	29.4kg
54828-220	HD380	AC 220V 1PH	6.4A		275	485	135	29.4kg



**54830** HD420 Super Powerful Type Demagnetizer

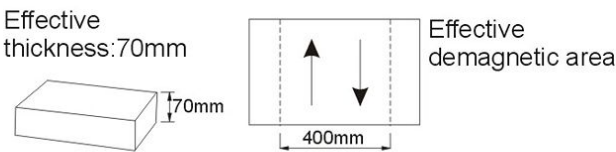

**Features :**

- ▶ Demagnetizing plate steel, large mold, tools etc...
- ▶ Big effective demagnetizing range: 400mm with thickness within 70mm
- ▶ Suitable for material such as high carbon steel, mold steel etc... which are difficult to be demagnetized.
- ▶ Suitable for long period usage.

Unit:mm

Order No.	Model	Voltage	Current	Usage interval	L	W	H	N.W.
54830-220	HD420	AC 220V 3PH	5.6A	5 min.stop for 60 min.usage	360	590	135	46kg
54830-380	HD420	AC 380V 3PH	3.2A		360	590	135	46kg

**54832** HD500 Super Powerful Type Demagnetizer

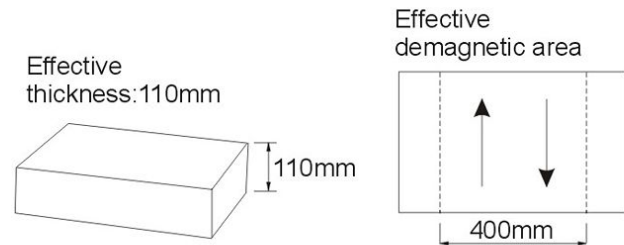

**Features :**

- ▶ Demagnetizing plate steel, large mold, tools etc...
- ▶ Big effective demagnetizing range: 400mm with thickness within 110mm
- ▶ Suitable for material such as high carbon steel, mold steel etc... which are difficult to be demagnetized.
- ▶ Suitable for long period usage.

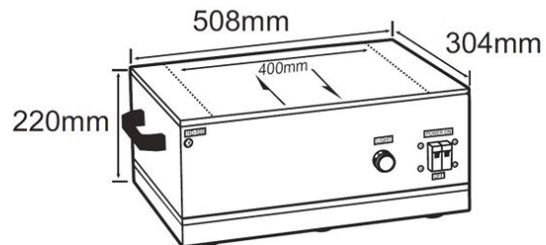

Unit:mm

Order No.	Model	Voltage	Current	Usage interval	L	W	H	N.W.
54832-220	HD500	AC 220V 3PH	10.5A	5 min.stop for 60 min.usage	304	508	220	70kg
54832-380	HD500	AC 380V 3PH	6.2A		304	508	220	70kg

MAGNETIC TOOLS

# Magnetic Tools

## 54834 HD620AD Super Powerful Demagnetizer Machine(Plate Type)



### Features :

- ▶ Ergonomic design with easy operation as well as the large range of effective area
- ▶ Automatic power save system
- ▶ Suitable for induction metal and molds etc...
- ▶ Demagnetizer and base can be purchase separately.

Unit:mm

Order No.	Model	Voltage	Current	Usage interval	L	W	H	N.W.
54834-220	HD620AD	AC 220V 3PH	11A	Continuous	620	430	760	Machine 69.5kg Base 28kg
54834-380	HD620AD	AC 380V 3PH	6.5A					

## 54836 HD Tunnel Type Demagnetizer



### Features :

- ▶ Tunnel design which suitable for mass production with non-mag convey belt application as well as long length item.
- ▶ Superb demagnetising effect on four sides of the gate, suitable for various metal materials especially stainless steel.
- ▶ Excellent thermal design which allows long period operation.

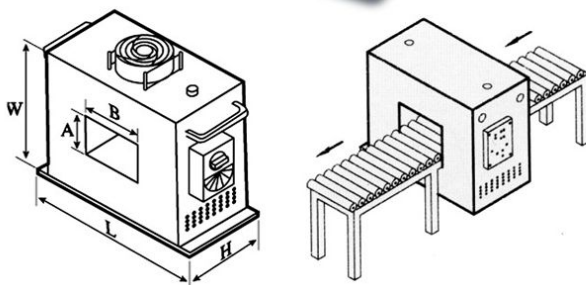

Unit:mm

Order No.	Model	Voltage	Current	Usage interval	L	W	H	A	B	N.W.
54836-01-220	HD1015	AC 220V	6A	Continuous	490	450	200	100	150	30kg
54836-01-380		AC 380V	4A							35kg
54836-02-220	HD1525	AC 220V	12A		590	510	200	150	250	42kg
54836-02-380		AC 380V	7A							47.6kg
54836-03-220	HD2545	AC 220V	32A		790	640	200	250	450	71kg
54836-03-380		AC 380V	20A							80kg

**54838** WL115C Chuck Controller

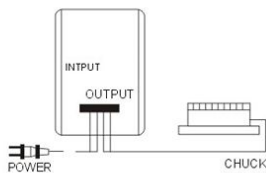

**Features :**

- ▶ Suitable for standard type of electric magnetic chucks.
- ▶ Operation time is 6 ~ 15 seconds with current capacity of 5A.
- ▶ Fine adjustment is available with LED light indication.
- ▶ Suitable for any kind of electric magnetic chucks.
- ▶ Split made is available for install in machines.

Unit:mm

Order No.	Model	Input Volt.	Output Volt.	Current	L	W	H	N.W.
54838-110	WL115C	AC 110V 1PH	DC 0-100V	5A	198	138	122	2.8kg
54838-220	WL115C	AC 220V 1PH						

**54840** HD510 Chuck Controller

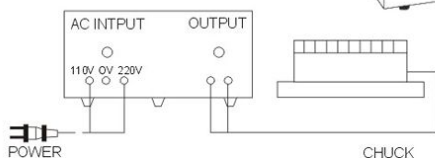
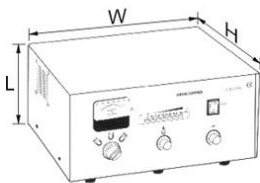

**Features :**

- ▶ Suitable for powerful type of electric magnetic chucks.
- ▶ Operation time is 6 ~ 15 seconds with current capacity of 10A/15A/20A.
- ▶ Fine adjustment is available with LED light indication.
- ▶ Suitable for any kind of electric magnetic chucks.
- ▶ Split made is available for install in machines.

Unit:mm

Order No.	Model	Input Volt.	Output Volt.	Current	L	W	H	N.W.
54840-10-110	HD510-10A	AC 110V 1PH	DC 0-120V	10A	150	330	260	15kg
54840-10-220	HD510-10A	AC 220V 1PH						
54840-15-220	HD510-15A	AC 220V 1PH		15A	150	330	260	20kg
54840-15-380	HD510-15A	AC 380V 1PH						
54840-20-220	HD510-20A	AC 220V 1PH		20A	180	385	295	32kg
54840-20-380	HD510-20A	AC 380V 1PH						

MAGNETIC TOOLS



# Magnetic Tools

## 54850 MSB150 Magnetic Pen



### Examples:



Order No.	Model	Dimension	Holding capacity
54850-150	MSB150	Min.135/Max.650	Max.1.8kg

## 54856 MPS Magnetic Bar Cleaner

MAGNETIC TOOLS

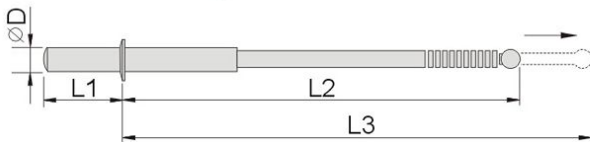
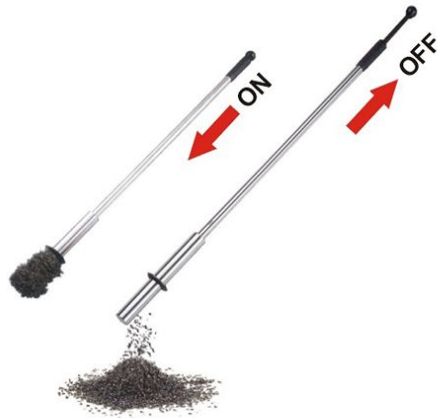

### Features :

- ▶ Strong magnetic force, lightweight and easy to operate.
- ▶ Protrudent and round front-end design is especially suitable for T-slot and concave slot.
- ▶ Permanent magnetic and simple construction, no maintenance needed.
- ▶ Removing metal chips left on various machines.
- ▶ Classifying parts for stamping and surface-treatment industries.

Order No.	Model	∅D	L1	L2	L3	N.W.
54856-600	MPS600S	32	110	490	640	0.9kg
54856-900	MPS900S	32	110	790	940	1.0kg
54856-1200	MPS1200S	32	160	1040	1240	1.6kg

### Examples:



Lathes Machine



Machining Center



Gear Hobbing Machine



Grinding Machine

**54858** MRT1240 Magnetic Bar Cleaner



**Features :**

- ▶ Suitable for removing iron scraps in T-slot and holes or unreachable place.

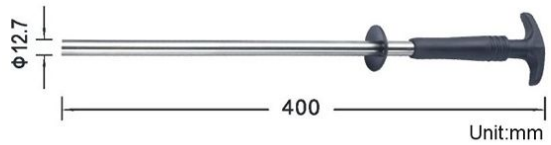

**Example**



**54860** HMC Magnetic Handler



HMC300  
HMC600

HMD200  
HMD700

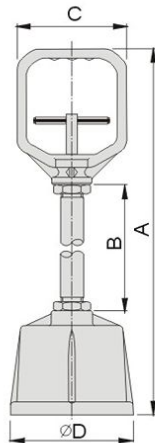

**Features :**

- ▶ Removing metal chips left on various type of machines.
- ▶ Classifying parts for stamping and surface-treatment industries.

**Example**



Unit:mm

Order No.	Model	D	A	B	C	N.W.
54860-01	HMC300	$\phi 114$	295	70	100	1.02kg
54860-02	HMC600	$\phi 114$	590	365	100	1.48kg
54860-03	HMD200	120X70	185	-	110	1.12kg
54860-04	HMD700	120X70	700	500	110	2.00kg

## Magnetic Tools

**54864**

EMBC-18

Magnetic Chip Cleaner



### Features :

- ▶ Sweeping metal chips in the factory floor.
- ▶ Increase efficiency and effectiveness.
- ▶ Reduce time-consuming on cleaning.
- ▶ Removing metal scraps in the same way as you walk.



MAGNETIC TOOLS



**54866** MSR Magnetic Cleaner

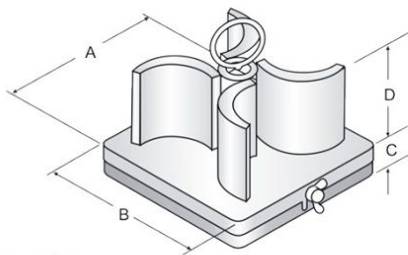
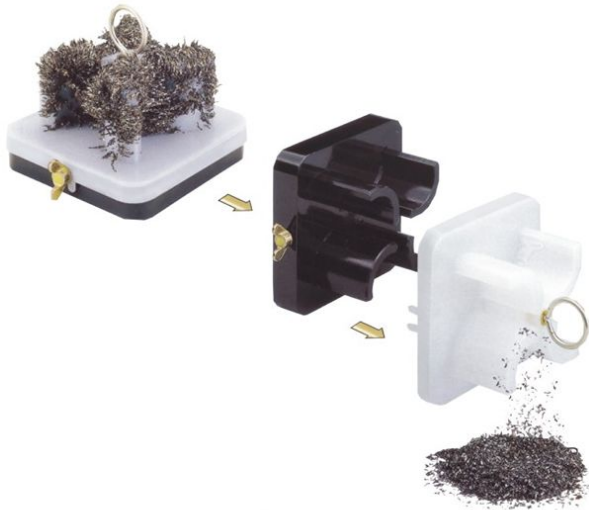

**Application:**

- Hydraulic power unit.
- Circulating lubrication oil tank.
- Oil slot of Wire-cut machine and EDMs
- Oil slot and water troughs of washers and oil purifier.

**Features :**

- ▶ Lightweight, easy to maintain.
- ▶ Strong and long magnetic force, perfect attraction even for micro metal powder.
- ▶ Powerful magnetism purifying and clean oil.

**Adequate q'ty used formation:**

- ▶ Hydraulic power unit:  $T \div 1/20Q = P$
- ▶ Circulating Lubrication oil tank:  $T \div Q = P$
- ▶ T: oil tank capacity
- ▶ Q: pump delivery
- ▶ P: example of contamination.

**Example**



Metal chips



Metal powder

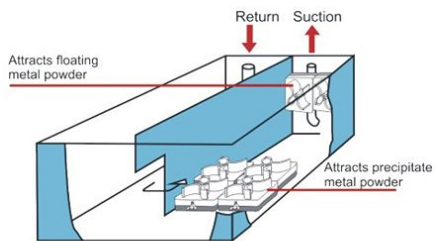

Coolant Tank

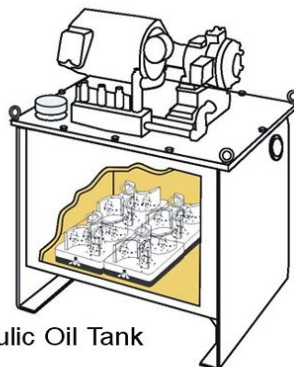

Hydraulic Oil Tank



Electric Discharge Machine

Unit:mm

Order No.	Model	A	B	C	D	Flux density	Body colour	N.W.
54866-100	MSR100	110	110	20	42	800Goe	Black	0.5kg
54866-300	MSR300	110	110	20	42	3000Goe	Red	0.75kg

# Magnetic Tools

## 54868 MBC Magnetic Bar Cleaner

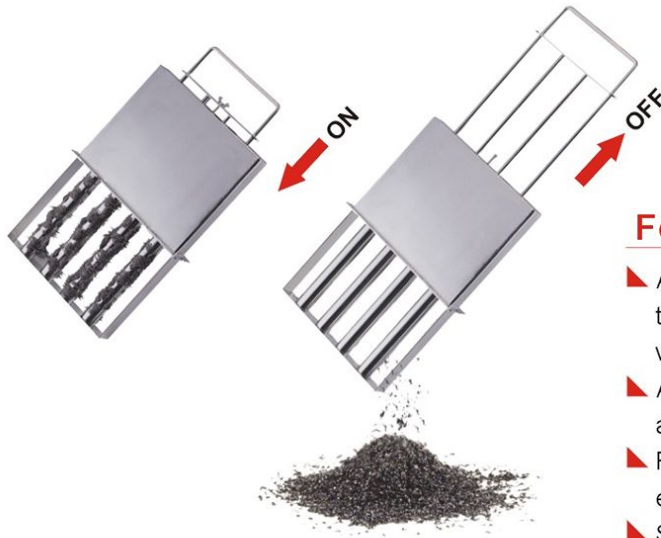

### Features :

- ▶ Attracting metal powder left in the cutting fluid tanks of CNC lathes, EDMs, machining center and wire-cutting machines.
- ▶ Applying special power magnet with superb attraction in radial.
- ▶ Fence gate design makes chip disposal more efficient.
- ▶ Small in size can add extra equipment in existing machine.

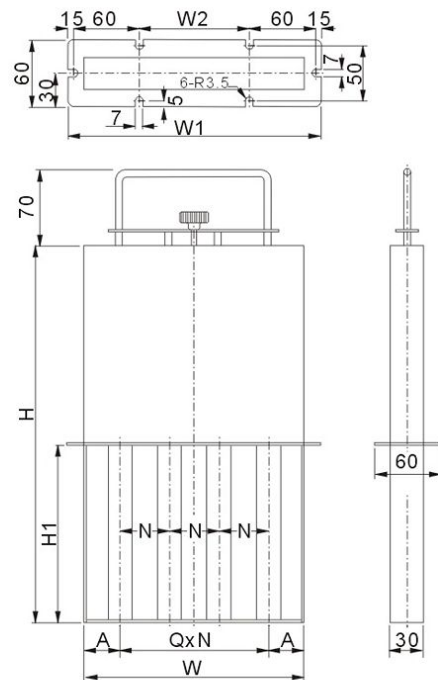
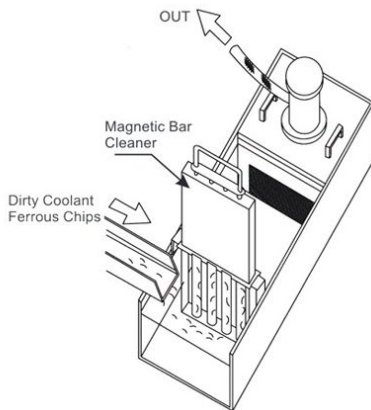

### Example



Unit:mm

Order No.	Model	A	H	H1	W	W1	W2	N Pitch	Q Bar Q'TY	N.W.
54868-02	MBC201604	32.5	340	160	200	250	100	45	4pcs	3.3kg
54868-04	MBC202504	32.5	520	250	200	250	100	45	4pcs	5.2kg
54868-06	MBC323006	35	620	300	320	370	220	50	6pcs	8.6kg
54868-08	MBC323706	35	760	370	320	370	220	50	6pcs	12.3kg

**54870** MTP150 Magnetic Taper



N.W. 2.5kg

**Features :**

- ▶ Compact and portable design, easy to operate.
- ▶ Guide bar helps the tap positioning precisely.
- ▶ Evenly force-delivering during operation prevent tap from breaking, reducing wear and cost.
- ▶ Quick chuck enables the tap to be easily loaded and unloaded.
- ▶ Powerful permanent-magnet seat, no maintenance needed.
- ▶ Suitable for M4~M12 tape.

**Applications**

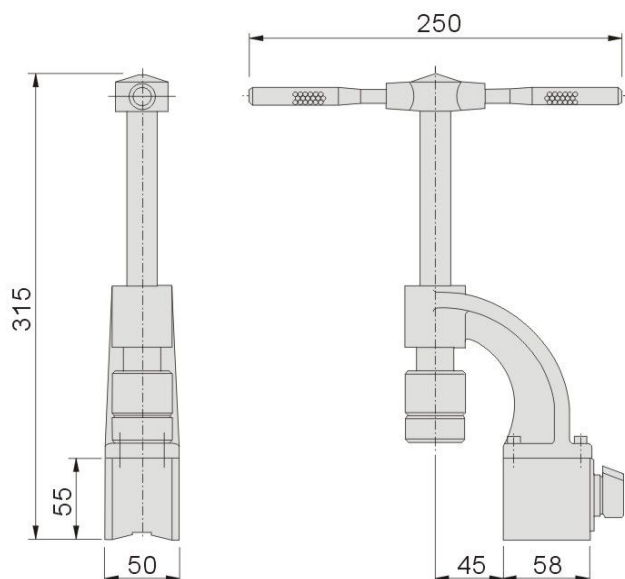
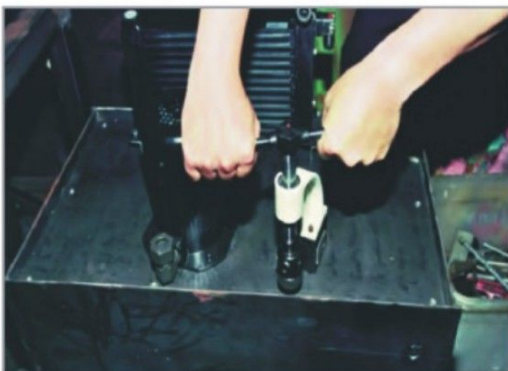



# Magnetic Tools

## 54871 MV120 Magnetic Clamping Block

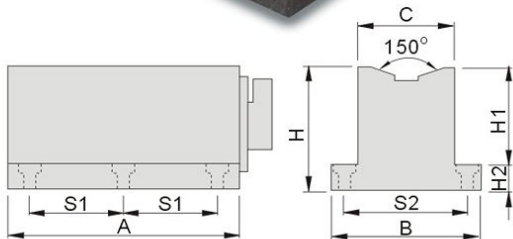

### Features :

- ▶ Fast setups of bar stock or round steel.
- ▶ Powerful magnetic base, ON-OFF switch.

### Applications:

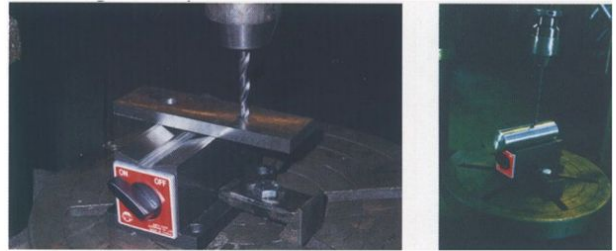

Unit:mm

Order No.	Model	Mag. Force		Dimension								N.W.
		V-face	Flat	A	B	C	H	H1	H2	S1	S2	
54871	MV120	110kgf	160kgf	118	76	50	62	50	12	48	62	2.5kg

MAGNETIC TOOLS

## 54872 HML100 Powerful Handle Magnet



### Features :

- ▶ Easily lifting large and thin steel plate.
- ▶ Separating steel and non-steel and also for screws and nuts.
- ▶ Permanent magnetic guaranteed.

Unit:mm

Order No.	Model	Spec.	Max. Weight	N.W.
54872	HML100	135x30x90	100lbs(45kg)	0.45kg

## 54873 AHL Magnetic Safe Catcher



### Features :

- ▶ Applying this catcher when operating pressing machines.
- ▶ ON-OFF switch operated by only single hand.
- ▶ Arm length 220mm.

Unit:mm

Order No.	Model	Mag. Spec.	Mag. Force	N.W.
54873-01	AHL-A	∅15x25	0.7kg	0.17kg
54873-02	AHL-B	∅20x25	2.5kg	0.20kg
54873-03	AHL-C	∅25x25	5.0kg	0.25kg

**54874** TCT Multi-function Mist Coolant System

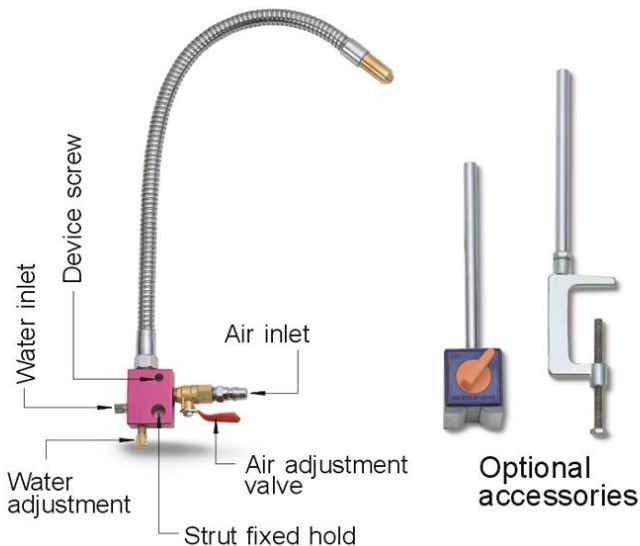

**Features :**

- ▶ Operating cooling, lubricating and removing metal chips at the same time.
- ▶ Increasing cost effectiveness, efficiency and durability of tools.
- ▶ Ensure better processing quality as well as performance of tools.
- ▶ Assisting better surface finished when processing hard alloy steels.
- ▶ Optional accessories can be used on drill machine and other machines.
- ▶ Random body anodize colour when ordering.

Unit:mm

Order No.	Model	Tube Length	Package size	N.W.
54874-250	TCT-250	250	41x29.5x20cm	0.55kg
54874-500	TCT-500	500	41x29.5x20cm	0.70kg

**54876** TCTB Multi-function Mist Coolant System



**Features :**

- ▶ Operating cooling, lubricating and removing metal chips at the same time.
- ▶ Increasing cost effectiveness, efficiency and durability of tools.
- ▶ Ensure better processing quality as well as performance of tools.
- ▶ Assisting better surface finished when processing hard alloy steels.
- ▶ Accessories can be used on drill machine and other machines.
- ▶ Magnetic base can be use on any metal surface or machines.
- ▶ Random body anodize colour when ordering.

Unit:mm

Order No.	Model	Tube Length	Package size	N.W.
54876-500	TCTB-500	500	29x16x9cm	1.7kg

# Magnetic Tools

## 54880 PA Magnetic Base Spray Nozzles



PA-10

PA-9

### Features :

- ▶ Suitable for drill, milling and grinding machines.
- ▶ Reducing temp. on tools for durability and performance.
- ▶ Easily to locate, tubes are free to adjusted and water volume control.
- ▶ With powerful magnetic base, it can be placed anywhere on steels.

Order No.	Model	Tube Length	Magnetic base spec.			Mag. Force (N)	N.W.
			L	W	H		
54880-01	PA-10	365	60	50	55	80kgf	1.6kg
54880-02	PA-9	365	60	50	55	80kgf	1.62kg

## 54882 PB Magnetic Base Spray Nozzles

MAGNETIC TOOLS

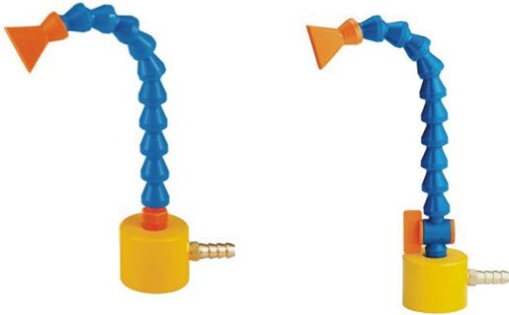

PB1

PB2

### 54882-03

- PB1(Mag.NO-OFF)
- |                  |      |
|------------------|------|
| Magnetic base    | 1set |
| 1/4"segment      | 10pc |
| 1"Flare Nozzle   | 1pc  |
| 1/4"PT connector | 1pc  |

### 54882-04

- PB2(Mag.NO-OFF)
- |                   |      |
|-------------------|------|
| Magnetic base     | 1set |
| 1/4"segment       | 10pc |
| 1"Flare Nozzle    | 1pc  |
| 1/4 Male PT valve | 1pc  |

## 54884 PC Magnetic Base Spray Nozzles

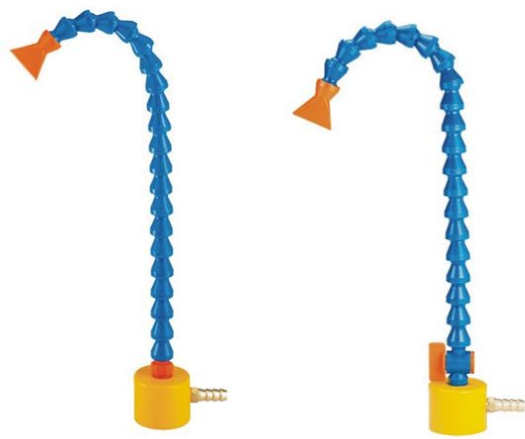

PC1

PC2

### 54884-05

- PC1(Mag.NO-OFF)
- |                  |      |
|------------------|------|
| Magnetic base    | 1set |
| 1/4"segment      | 20pc |
| 1"Flare Nozzle   | 1pc  |
| 1/4"PT connector | 1pc  |

### 54884-06

- PC2(Mag.NO-OFF)
- |                   |      |
|-------------------|------|
| Magnetic base     | 1set |
| 1/4"segment       | 20pc |
| 1"Flare Nozzle    | 1pc  |
| 1/4"Male PT valve | 1pc  |



**54886** PD **Adjustable Coolant Hoses & Valves**



1/4" (36cm Hose Kit)

**54886-01 PD1**

- 1/4" Male PT or NPT valve
- 1/4" segment 20pcs
- 1/16" or 1/8" or 1/4" Nozzle 1pc



1/4" (36cm Hose Kit)

**54886-02 PD2**

- 1/4" Female PT or NPT valve
- 1/4" segment 20pcs
- 1/16" or 1/8" or 1/4" Nozzle 1pc



3/8" (36cm Hose Kit)

**54886-03 PD3**

- 3/8" Male PT or NPT valve
- 3/8" segment 16pcs
- 1/4" or 3/8" or 1/2" Nozzle 1pc



3/8" (36cm Hose Kit)

**54886-04 PD4**

- 3/8" Female PT or NPT valve
- 3/8" segment 16pcs
- 1/4" or 3/8" or 1/2" Nozzle 1pc



1/2" (35cm Hose Kit)

**54886-05 PD5**

- 1/2" Male PT or NPT valve
- 1/2" segment 12pcs
- 1/4" or 3/8" or 1/2" Nozzle 1pc



1/2" (35cm Hose Kit)

**54886-06 PD6**

- 1/2" Female PT or NPT valve
- 1/2" segment 12pcs
- 1/4" or 3/8" or 1/2" Nozzle 1pc

MAGNETIC TOOLS

## Magnetic Tools

**54890**

MD

Magnetic Base



N.W.1.1kg

### Features :

- ▶ Suitable for applying on dial indicator, LED light, coolant nozzle and diamond tip etc...
- ▶ Mag. Force: 80kgf
- ▶ Magnetic base dimension: (LxWxH)  
60mm x 50mm x 55mm

**54892**

MT

Permanent Magnetic Lifter(Handle Type)



### Features :

- ▶ Loading Capacity: MT-6S (80 kgf)  
MT-10S (160 kgf)

Unit:mm

Order No.	Model	L	W	H	N.W.
54892-01	MT-6S	60	50	55	1.15kg
54892-02	MT-10S	120	50	55	2.00kg

**54894**

MTT

Magnetic Lifter



N.W.2.0kg

### Features :

- ▶ New structure design, ON-OFF switch on the subject's surface.
- ▶ Mag. Force: 150kgf
- ▶ Magnetic base dimension: (LxWxH)  
140mm x 100mm x 190mm

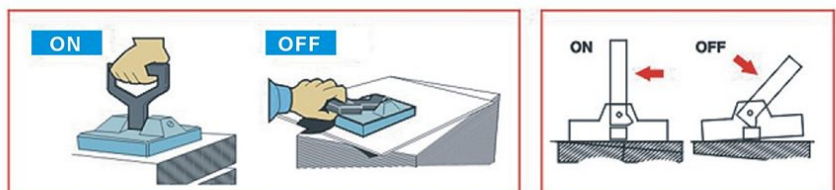

**54896** MH Magnetic Holder



Unit:mm

Order No.	Model	Mag. Force	Spec.	N.W.
54896-02	MH-18H	5 kgf	∅ 18x8	0.016kg
54896-03	MH-25H	9 kgf	∅ 25x10	0.04kg
54896-04	MH-30R	15 kgf	∅ 30x25	0.11kg
54896-05	MH-40R	30 kgf	∅ 40x30	0.24kg
54896-06	MH-50R	50 kgf	∅ 50x40	0.50kg
54896-07	MH-26S	10 kgf	26x26x25	0.11kg
54896-08	MH-60S	20 kgf	60x26x25	0.25kg

**54898** MTB Magnetic Base



Unit:mm

Order No.	Model	Hole spec.	Magnetic Base Spec.			Mag. Force	N.W.
			L	W	H		
54898-01	MTB35	M5x0.8	35	30	35	25kgf	0.2kg
54898-02	MTB60	M8x1.25	60	50	55	80kgf	1.0kg
54898-03	MTB80		75	50	55	100kgf	1.3kg
54898-04	MTB120		120	50	55	160kgf	2.0kg
54898-05	MTB40	M6x1.0	40	40	40	50kgf	0.6kg

MAGNETIC TOOLS



# Magnetic Tools

## 54900 CZA Magnetic Indicator Stands



### Features :

- ▶ Standard type.
- ▶ Powerful magnetic base.
- ▶ Suitable for applying on dial indicator etc...

Unit:mm

Order No.	Model	Main Lever	Sub Lever	Base spec. L x W x H	Screw hole	Mag. Force	N.W.
54900	CZA-8C	∅12X176	∅10X160	60X50X55	M8x1.25	80kgf	1.4kg

## 54902 CZB Magnetic Stands With Fine Adjustment



### Features :

- ▶ Fine-tuning type with spring, more flexible.
- ▶ Powerful magnetic base.
- ▶ Suitable for applying on dial indicator etc...

Unit:mm

Order No.	Model	Main Lever	Sub Lever	Base spec. L x W x H	Screw hole	Mag. Force	N.W.
54902	CZB-8C	∅12X176	∅10X150	60X50X55	M8x1.25	80kgf	1.4kg

## 54904 CZC Extra Stem Magnetic Indicator Stand With Fine Adjustment



### Features :

- ▶ Fine-tuning type with spring, more flexible.
- ▶ One main lever, two sub levers.
- ▶ Powerful magnetic base.
- ▶ Suitable for applying on dial indicator etc...

Unit:mm

Order No.	Model	Main Lever	Sub Lever (middle)	Sub Lever	Base spec. L x W x H	Screw hole	Mag. Force	N.W.
54904-01	CZC-10B	∅20X170	∅14X170	∅12X127	73X50X55	M8x1.25	100kgf	2.0kg
54904-02	CZC-10DL	∅20X350	∅14X165	∅12X129	117X50X55	M10x1.5	130kgf	3.5kg

**54916** NHA High Precision Magnetic Stand



**Features :**

- ▶ New dovetail fine-tuning device, more accurate and stability.
- ▶ Non-magnetic stainless made of main and sub lever.
- ▶ Powerful magnetic base.

Unit:mm

Order No.	Model	Screw hole	Main Lever	Sub Lever	Base spec. L x W x H	Mag. Force	N.W.
54916	NHA	M8X1.25	∅12X175	∅10X160 Fine-tuning	48X40X49	35kgf	1.2kg

☞ Dial indicator please refer Page. D31~32

**54918** NHB High Precision Magnetic Stand



**Features :**

- ▶ New dovetail fine-tuning device, more accurate and stability.
- ▶ Non-magnetic stainless made of main and sub lever.
- ▶ Powerful magnetic base.

Unit:mm

Order No.	Model	Screw hole	Main Lever	Sub Lever	Base spec. L x W x H	Mag. Force	N.W.
54918	NHB	M8X1.25	∅14X200	∅12X165 Fine-tuning	60X50X55	80kgf	1.5kg

**54920** NHC High Precision Magnetic Stand



**Features :**

- ▶ New dovetail fine-tuning device, more accurate and stability.
- ▶ Non-magnetic stainless made of main and sub lever.
- ▶ Powerful magnetic base.

Unit:mm

Order No.	Model	Screw hole	Main Lever	Sub Lever	Base spec. L x W x H	Mag. Force	N.W.
54920	NHC	M10X1.5	∅16X250	∅14X180 Fine-tuning	80X50X55	100kgf	2.3kg

# Magnetic Tools

## 54922 NSA Mechanical Universal Magnetic Stands



☞ Dial indicator please refer Page. D31~32

### Features :

- ▶ Mini & economic type.
- ▶ Main axle is made of aluminum.
- ▶ Mechanic structure, no leaking oil problem.
- ▶ L1=55,L2=50,L3=30

Unit:mm

Order No.	Model	Base spec. L x W x H	Gauge hole	Mag. Force	N.W.
54922-01	NSA01	35X30X35	8.0 ±0.02	30kgf	0.3kg
54922-02	NSA02				

## 54925 BS320 Mechanical Universal Magnetic Stands



### Features :

- ▶ Medium & economic type
- ▶ Fine-tuning on dovetail clamping.
- ▶ L1=112,L2=102,L3=65

Unit:mm

Order No.	Model	Base spec. L x W x H	Gauge hole	Mag. Force	N.W.
54925	BS320	60X50X55	8.0 ±0.02	80kgf	1.24kg

## 54926 NSC Mechanical Universal Magnetic Stands



### Features :

- ▶ Mini & economic type.
- ▶ Fine-tuning structure on base, easy to adjust.
- ▶ Mechanic structure, no leaking oil problem.
- ▶ NSC01 (L1=50,L2=50,L3=65)  
NSC02 (L1=55,L2=55,L3=70)

Unit:mm

Order No.	Model	Base spec. L x W x H	Gauge hole	Mag. Force	N.W.
54926-01	NSC01	40X40X40	8.0 ±0.02	50kgf	0.7kg
54926-02	NSC02			50kgf	0.7kg



**54927A** BS100 Universal Arm Magnetic Base

**Features :**

- ▶ Mechanical construtere adopted
- ▶ Universal arm can be set at any angle.
- ▶ Fine-tuning dovetail with  $\varnothing 8\text{mm}$
- ▶ Suitable for various dial indicators



Fine-tuning dovetail

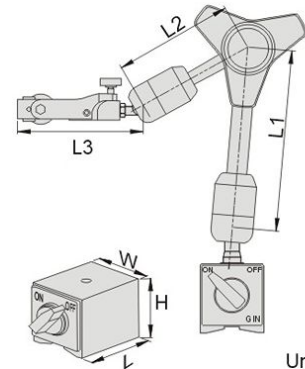

Unit:mm

Order No.	Model	Lever spec.			Mag.base spec.			Mag. Force	N.W.
		L1	L2	L3	L	W	H		
54927A-01	BS100A	62	56	88	40	40	40	50kgf	0.72kg

**54927B** BS100 Universal Arm Magnetic Base

**Features :**

- ▶ Mechanical construtere adopted
- ▶ Universal arm can be set at any angle.
- ▶ Suitable for various dial indicators
- ▶ Adopting one-piece fine-tuning dovetail with  $\varnothing 8\text{mm}$ , no backlash and easily set zero.



One-piece fine-tuning dovetail

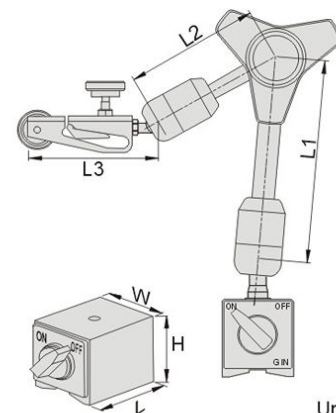

Unit:mm

Order No.	Model	Lever spec.			Mag.base spec.			Mag. Force	N.W.
		L1	L2	L3	L	W	H		
54927B-01	BS100AH	62	56	75	40	40	40	50kgf	0.72kg

# Magnetic Tools

## 54928 NOGA FAT >> NOGA Articulated Holders FAT



### Features :

- ▶ Powerful ON-OFF magnetic base.
- ▶ Central locking mechanism with designed spring.
- ▶ Black finished arms.
- ▶ Universal swivel clamp for all dial and test indicator. holds  $\varnothing 6\text{mm}$ ,  $\varnothing 8\text{mm}$ ,  $\varnothing 3/8"$  and  $1/4"$  dovetails and back lug.
- ▶ Instant fixation in any position.

MAGNETIC TOOLS

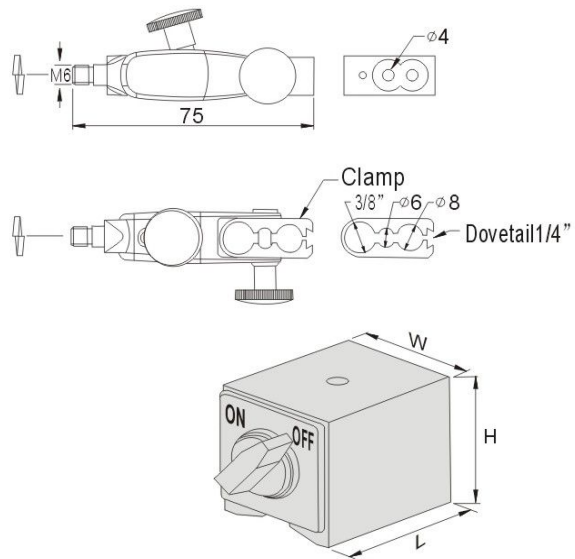
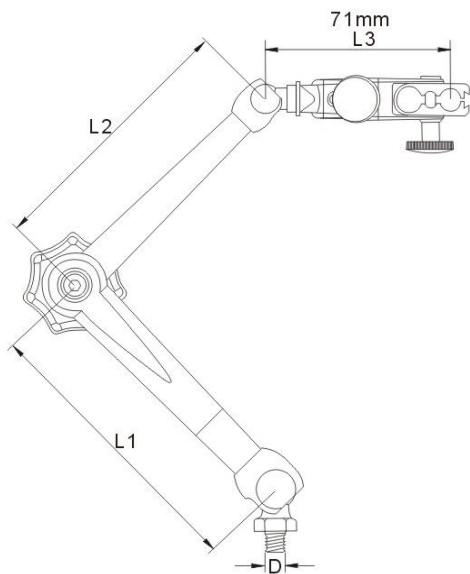

☞ Dial indicator please refer Page. D31~32

Unit:mm

Order No.	Model	Arm length			Magnetic base spec.			Thread	Force (N)	N.W.
		L1	L2	L1+L2+L3	W	H	L			
54928-01	NF61003	56	51	178	30	35	40	Ext. M5	320	0.6kg
54928-02	DG61003	110	101	282	50	55	60	Ext. M8	800	1.4kg
54928-03	MG61003	133	113	317	50	55	60	Ext. M8	800	1.9kg
54928-04	MA61003	286.5	222.5	580	50	55	120	Ext. M10x1.25	1300	5.1kg

**54929** BS250 Universal Arm Magnetic Base

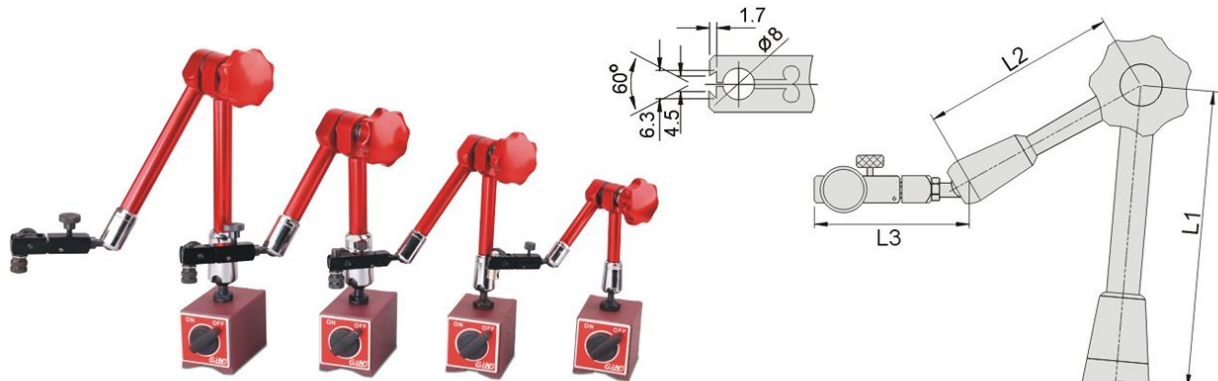

**54940** BS350

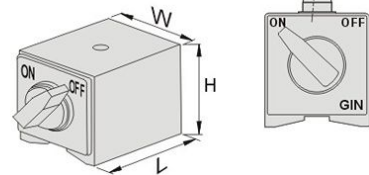

**Features :**

- ▶ Mechanical construture adopted
- ▶ Universal arm can be set at any angle.
- ▶ Suitable for various dial indicators
- ▶ Adopting one-piece fine-tuning dovetail with  $\varnothing 8\text{mm}$ , no backlash and easily set zero.

One-piece fine-tuning dovetail

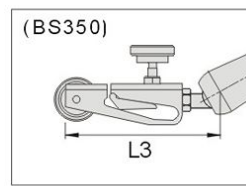

Optional accessory: P.D31

Unit:mm

Order No.	Model	Lever spec.			L3	Mag.base spec.			Mag. Force	N.W.
		L1	L2	L3		L	W	H		
54929-01	BS250S	85	80	60	60	50	55	80kgf	1.28kg	
54929-02	BS250M	120	120	65	60	50	55	80kgf	1.42kg	
54929-03	BS250L	140	125	80	75	50	55	100kgf	1.96kg	
54929-04	BS250LL	190	175	80	75	50	55	100kgf	2.06kg	

Order No.	Model	Arm length			Magnetic base spec.			Force (N)	N.W.
		L1	L2	L3	L	W	H		
54940-01	BS350S	85	80	60	60	50	55	80kgf	1.28kg
54940-02	BS350M	120	120	65	60	50	55	80kgf	1.42kg
54940-03	BS350L	140	125	80	75	50	55	100kgf	1.96kg



# Magnetic Tools

## 54930 BS330 Universal Arm Magnetic Base



### Features :

- ▶ Mechanical arm.
- ▶ Powerful ON-OFF magnetic base.
- ▶ Universal swivel clamp for all dial and test indicator.
- ▶ Holds  $\varnothing 8\text{mm}$  and  $1/4''$  dovetails and back lug.
- ▶ Instant fixation in any position.

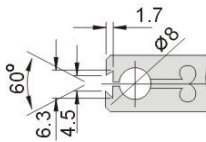

Optional accessory: P.D31  
Dial indicator

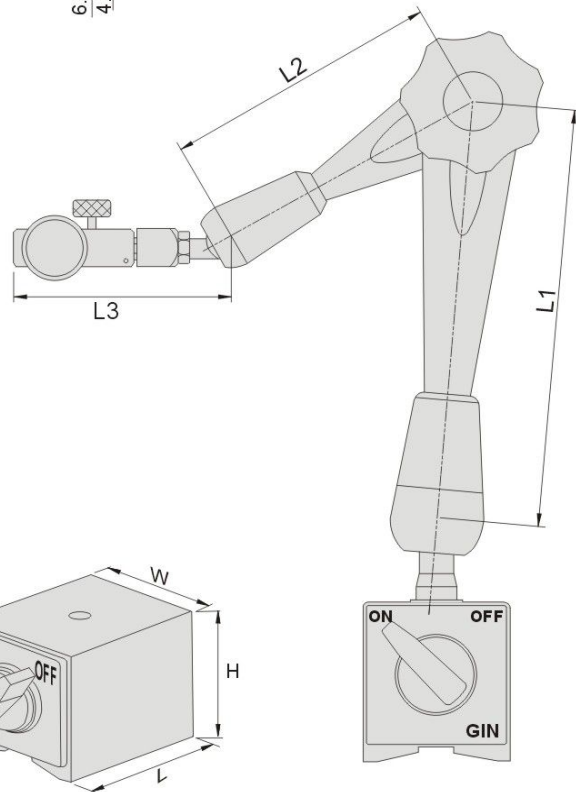

Dial indicator please refer Page. D31~32

Unit:mm

Order No.	Model	Arm length		L3	Magnetic base spec.			Force (N)	N.W.
		L1	L2		L	W	H		
54930-01	BS330S	110	75	65	60	50	55	80kgf	1.5kg
54930-02	BS330M	150	98	65	60	50	55	80kgf	1.7kg
54930-03	BS330L	185	145	70	80	50	55	100kgf	2.2kg

**54933** BS333 Universal Arm Magnetic Base



One-piece fine-tuning clamping

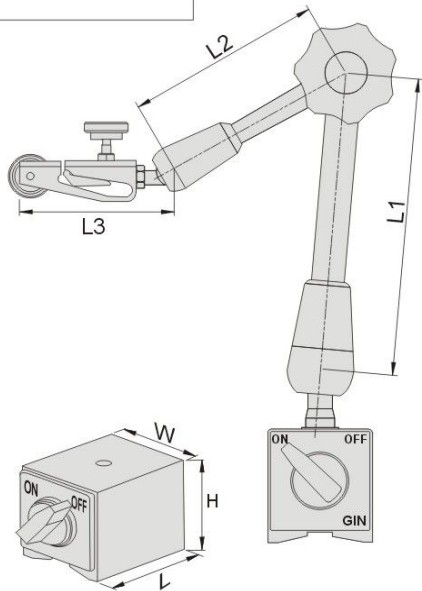

**Features :**

- ▶ New locking design with strong clamping force.
- ▶ Made of hardened steel for all the wear parts with HRC58°.
- ▶ CNC machined for main parts.
- ▶ 1/4" dovetail and Ø8mm holder design for dial guage.

Optional accessory: P.D31 Dial indicator

MAGNETIC TOOLS

Dial indicator please refer Page. D31~32

Unit:mm

Order No.	Model	Arm length			Magnetic base spec.			Force (N)	N.W.
		L1	L2	L3	L	W	H		
54933-01	BS333SS	62	52	75	40	40	40	50kgf	0.7kg
54933-02	BS333S	100	82	75	60	50	55	80kgf	1.4kg
54933-03	BS333M	145	95	75	75	50	55	100kgf	2.0kg
54933-04	BS333L	175	125	75	75	50	55	100kgf	2.3kg

# Magnetic Tools

## 54934 BS300 Universal Arm Magnetic Base



### Features :

- ▲ Precision hydraulic arm.
- ▲ Powerful ON-OFF magnetic base.
- ▲ Universal swivel clamp for all dial and test indicator.
- ▲ Holds  $\varnothing 8\text{mm}$  and  $1/4"$  dovetails and back lug.

MAGNETIC TOOLS



Optional accessory: P.D31  
Dial indicator

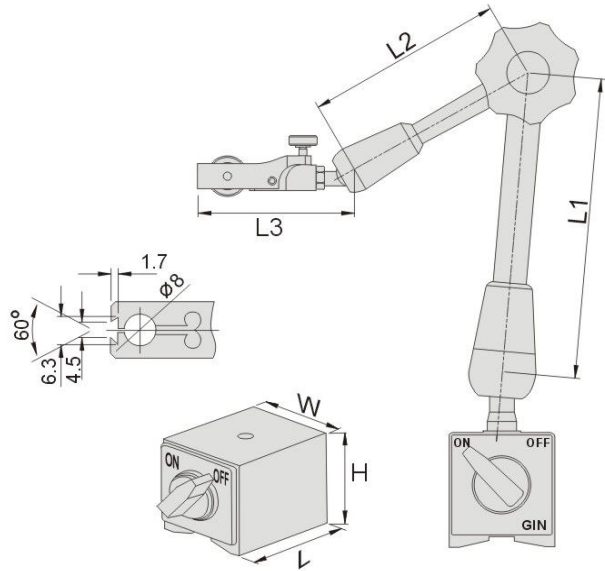

Dial indicator please refer Page. D31~32

Unit:mm

Order No.	Model	Arm length			Magnetic base spec.			Force (N)	N.W.
		L1	L2	L3	L	W	H		
54934-00	BS300SS	80	80	75	60	50	55	80kgf	1.34kg
54934-01	BS300S	120	118	70	80	50	55	100kgf	1.9kg
54934-02	BS300M	168	166	70	80	50	55	100kgf	2.0kg
54934-03	BS300L	285	280	95	120	50	55	160kgf	3.3kg



**54945** BS Universal Arm Magnetic Base



One-piece fine-tuning dovetail

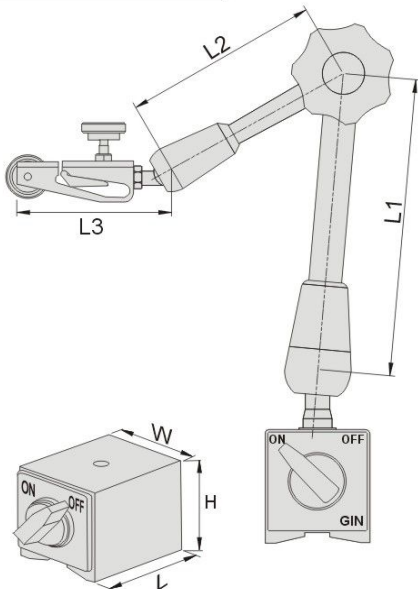

**Features :**

- ▶ Mechanical construture adopted
  - ▶ Universal arm can be set at any angle.
  - ▶ Suitable for various dial indicators
  - ▶ Adopting one-piece fine-tuning dovetail with  $\varnothing 8\text{mm}$ , no backlash and easily set zero.
- Optional accessory: P.D31 Dial indicator

MAGNETIC TOOLS

Unit:mm

Order No.	Model	Arm length			Magnetic base spec.			Force (N)	N.W.
		L1	L2	L3	L	W	H		
54945-00	BS340	135	110	65	60	50	55	80kgf	1.58kg
54945-02	BS340H	135	110	65	60	50	55	80kgf	1.58kg
54945-03	BS360H	145	130	70	75	50	55	100kgf	1.96kg