

Precision Machinery



J01-J26

INDEX

J01~10

Chamfering Machines



69000 J01



69010 J01



69020 J01



69030/40 J02



69050 J03



69060 J03



69070 J04



69080 J04



69090 J05



69100 J05



69110 J06



69120 J06



69130 J07



69140 J07



69150 J08



69160 J09



69180 J10

J11~21

Small Machinery



69190 J11



69200 J13



69210 J13



69220 J14



69230 J15



69240 J15



69250 J16



69260 J16



69270 J17



69280 J17



69290 J18



69300 J18



69310 J19



69320 J19



69330 J20



69340 J20



69350 J21



69360 J21

J22~26

Tapping Machine



69400 J22



69410 J23



69420 J23



69430 J24



69440 J24



69450 J25



69460 J26

Precision Machinery

69000 GT-C3 Portable Regular Chamfering Machine

69010 GT-R3 Portable Irregular Chamfering Machine



GT-C3

HITACHI



GT-R3

HITACHI

Specify voltage when ordering.

Order No.	69015-110-1	69015-110-1V	69015-220-1	69015-220-1V
Model	GT-100F	GT-100FV	GT-100F	GT-100FV
轉速(r.p.m)	固定轉速 11000	可調轉速 2800~11000	固定轉速 11000	可調轉速 2800~11000
Motor	110V,50/60Hz		220V,50/60Hz	
Capability	0~3mm			
Machine Size	100x70x8mm			
Guide rail length	670W 6.0A			
N.W/G.W	2.4/2.8kgs			
Pack Size	38cm x 13cm x14cm			

69020 GT-100C Portable Regular Chamfering Machine



BOSCH



Features:

- ▶ Adopting flat face mill cutting, swivel base angle to make cutter flute to be recycled used for cost reduction.
- ▶ Two adjustment function, the original L type (Fig. 1); the new for V type (Fig. 2).
- ▶ New V type is more energy saving, surface finish are much more smoother after chamfered.

Specify voltage when ordering.

Order No.	69020-110-1	69020-110-1V	69020-220-1	69020-220-1V
Model	GT-100C	GT-100CV	GT-100C	GT-100CV
轉速(r.p.m)	固定轉速 11000	可調轉速 2800~11000	固定轉速 11000	可調轉速 2800~11000
馬達	110V,50/60Hz單相		220V,50/60Hz單相	
倒角能力(L型)	0~3mm			
倒角能力(V型)	0~5mm(須加工2次)			
工作臺尺寸	100x70x8mm			
非負載馬達	670W 6.0A			
刀片規格	SPMW 0903 ADTR (訂購編號: 69020-01)			
N.W/G.W	2.4/2.8kgs			
Pack Size	38cm x 13cm x14cm			

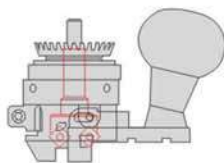

Fig. 1

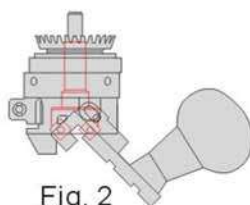

Fig. 2

69030
GT-100R
Portable Irregular type Chamfering Machine

Back



Front

GT-100R BOSCH
69035
GT-100FR
Portable Irregular type Chamfering Machine

GT-100CR Dual-use body
Fig⑩

100R Fig①

100F Fig②

100R Fig③

BOSCH
可調轉速主機

NOTE:

 GT-100CR install with fig. 1 for irregular chamfer
 GT-100CR removes bearing and install with fig. 2 for
 regular chamfer.

Above two function share the same body like fig. 10.

Optional Accessories

Order No.	Name	Spec.	Fig
69035-01	GT-100R Plate	∅100x∅30x∅6mm	①
69035-02	GT-100C Square	100x70x8mm	②
69035-03	Bearing	635ZZ	③
69035-04	GT-100R Tool		④
69035-06	GT-100R Insert 2R		⑥
69035-07	GT-100R Insert 3R		⑦
69035-08	GT-100C Insert	SPMW0903ADTR	⑧

Examples:

Type V GT-100C



Type V GT-100C



Type L GT-100C及GT-100F

Optional:
Radius Chamfer
only
Fig④

 2R Insert
Fig⑥

 Insert
Fig⑧

 3R Insert
Fig⑦

Order No.	69030-110-1	69030-110-1V	69030-220-1	69030-220-1V	69035-110-1	69035-110-1V	69035-220-1	69035-220-1V
Model	GT-100R	GT-100RV	GT-100R	GT-100RV	GT-100FR	GT-100FRV	GT-100FR	GT-100FRV
轉速(r.p.m)	固定轉速 11000	可調轉速 2800~11000	固定轉速 11000	可調轉速 2800~11000	固定轉速 11000	可調轉速 2800~11000	固定轉速 11000	可調轉速 2800~11000
馬達	110V,50/60Hz單相		220V,50/60Hz單相		110V,50/60Hz單相		220V,50/60Hz單相	
倒角能力	0~3mm							
工作臺尺寸	100x70x8mm							
導軌長度(100R)	∅100x30x6mm							
內孔最小外徑尺寸(100R)	∅20mm							
非負載馬達	670W 6.0A							
N.W/G.W	2.4/2.8kgs							
Pack Size	38x13 x14cm							



Precision Machinery

69050

GA200

Powerful Portable Chamfering Machine

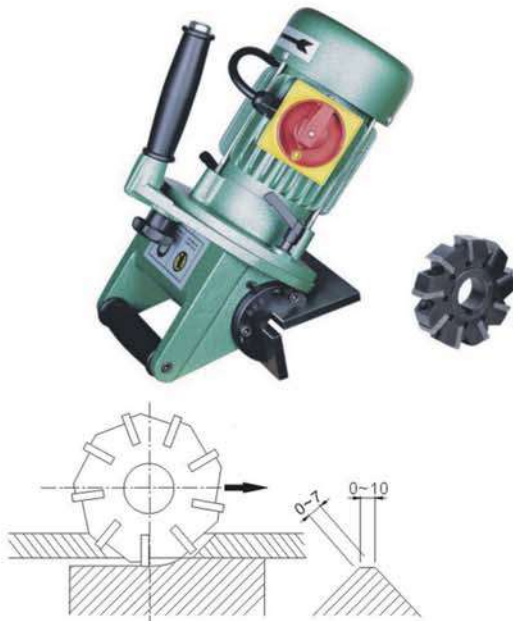

Features:

- ▶ Adopting concept of side mill cutting, rapidly shifting for inserts.
- ▶ Capable of chamfering any metal material.
- ▶ Adjustable swivel track from 15° to 45° for any angular chamfering demand.
- ▶ Chamfering capability 0~7C, 0~10mm/45°
- ▶ Track size : 200mm x 78mm x 9mm
200mm x 45mm x 9mm
- ▶ Blade spec.: SPUN1203 x 9 pcs
- ▶ Product size: 36mm x 200mm x 260mm

Specify voltage when ordering.

Order No.	Model	Capability	Bevel Angle	Motor	Voltage	N.W./G.W. Pack Size
69050-220-3	GA200	0~7mm (Twice)	15°~45°	1HP 3500RPM	220V,50/60Hz 3PH	11kgs/13kgs 40.5cmx30cmx30cm
69050-380-3					380V,50/60Hz 3PH	

69060

GS250

Powerful Portable Chamfering Machine



Features:

- ▶ Adopting concept of side mill cutting, rapidly shifting for inserts.
- ▶ Capable of chamfering any metal material.
- ▶ Adjustable swivel track from 15° to 45° for any angular chamfering demand.
- ▶ Chamfering capability 0~14C, 0~20mm/45°
- ▶ Track size : 250mm x 75mm x 9mm
250mm x 50mm x 9mm
- ▶ Blade spec.: SEKN120308 x 12 pcs
- ▶ Product size: 36mm x 200mm x 260mm
- ▶ Accessories: ∅61.5 x ∅22x12.8mm x 1pc
∅61.5 x ∅22x11.3mm x 1pc

Specify voltage when ordering.

Order No.	Model	Capability	Bevel Angle	Motor	Voltage	N.W./G.W. Pack Size
69060-220-3	GS250	0~14C, 0~20mm/45°	15°~45°	2HP 3500RPM	220V,50/60Hz 3PH	24kgs/27kgs 55cmx42cmx32cm
69060-380-3					380V,50/60Hz 3PH	

69090
GB320
Sanding Wheel Type Chamfering Machine
GB320

盤形砂布輪

Features:

- ▲ Apply sanding wheel for de-burr.
- ▲ Suitable for steel, cast iron and hardened parts.
- ▲ Burr occurred if applied on aluminum or soft iron.
- ▲ Easy to operate and safety
- ▲ Railway spec.: 320mm x 120mm x 12mm
320mm x 28mm x 12mm
- ▲ Motor: 1HP
- ▲ Accessory: Sanding Wheel spec.
∅ 165mm x ∅ 2mm (#60)
- ▲ Machine Size: 320mm x 500mm x 370mm

69092
GB320A
CBN Wheel Type Chamfering Machine
GB320A

CBN砂輪

特點:

- ▲ 此款倒角機特別改良將砂布輪改成CBN砂輪。
- ▲ 適用於各種鋼鐵、及熱處理后硬度高的鋼料。
- ▲ 倒角時的切削能力極為快速,且CBN砂輪耐用度極強。倒角表面極為光亮均勻。
- ▲ 切削力極為穩定,倒角時速度只要控制穩定,表面能達到極佳效果。
- ▲ 附件: CBN砂輪 ∅145x∅31.75xT23 CBN60
(訂購編號: 69092-01)

Specify voltage when ordering.

Order No.	Model	Capability	Bevel Angle	Motor	Voltage	N.W./G.W. Pack Size
69090-110-1	GB320	0~3mm	45°	1HP 3500RPM	110V,50/60Hz,1PH	25kgs/27kgs 46cmx36cmx38cm
69090-220-1					220V,50/60Hz,1PH	
69090-220-3					220V,50/60Hz,3PH	
69090-380-3					380V,50/60Hz,3PH	
69092-110-1	GB320A	0~3mm	45°	1HP 3500RPM	110V,50/60Hz,1PH	25kgs/27kgs 46cmx36cmx38cm
69092-220-1					220V,50/60Hz,1PH	
69092-220-3					220V,50/60Hz,3PH	
69092-380-3					380V,50/60Hz,3PH	



Precision Machinery

69100

GC500

Dual Function Chamfering Machine



500B Features:



- Apply grinding wheel to chamfer, specially for hardened and special treatment workpieces.

500BR Features:



- Adopting Face milling for better smooth surface and energy saving.
- Suitable for any material, not including heat treatment material.

500C Features:



- Two in one type, interchangeable for grinding wheel & face mill
- Suitable for any material.

- Railway Spec.: 500mmx100mmx12mm, 500mmx40mmx12mm,
- Insert Spec: SEKN1203x5pcs(500BR)
- Machine Size: 500mmx420mmx350mm,
- Accessory: Face Mill $\varnothing 50 \times \varnothing 17 \times 35$ mm
- Grinding Wheel: $\varnothing 100 \times \varnothing 17 \times 50$ mm
- (WA60,K5,VA6)(500B)

Optional accessories:

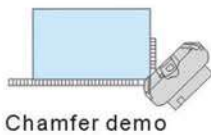

Order No.	Item	Spec.	Compatibility
69100-01	Insert	SEKN1203 x 10pcs	500BR/500C
69100-02	Bowl Wheel	$\varnothing 100 \times \varnothing 17 \times 50$ mm	500B
69100-03	Face Mill	$\varnothing 50 \times \varnothing 17 \times 35$ mm	500BR/500C

Specify voltage when ordering.

Order No.	Model	Capability	Bevel Angle	Motor	Voltage	N.W./G.W. Pack Size
69100-01-110-1	GC500B	0~3mm	45°	1HP 3500RPM	110V,50/60Hz,1PH	28kgs/31kgs 55cmx44cmx38cm
69100-01-220-1					220V,50/60Hz,1PH	
69100-01-220-3					220V,50/60Hz,3PH	
69100-01-380-3					380V,50/60Hz,3PH	
69100-02-110-1	GC500BR	0~3mm	45°	1HP 3500RPM	110V,50/60Hz,1PH	
69100-02-220-1					220V,50/60Hz,1PH	
69100-02-220-3					220V,50/60Hz,3PH	
69100-02-380-3					380V,50/60Hz,3PH	
69100-03-110-1	GC500C	0~3mm	45°	1HP 3500RPM	110V,50/60Hz,1PH	
69100-03-220-1					220V,50/60Hz,1PH	
69100-03-220-3					220V,50/60Hz,3PH	
69100-03-380-3					380V,50/60Hz,3PH	

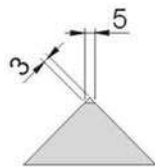
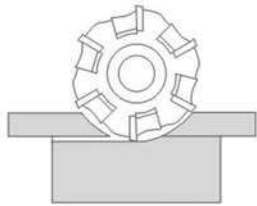
69110
GA500
Side Mill Type Chamfering Machine

Features:

- ▶ Apply Side End Milling concept with rapid shifting inserts (6 pcs)
- ▶ Suitable for steel, cast iron and hardened parts.
- ▶ Railway spec.: 500mm x 100mm x 12mm
500mm x 40mm x 12mm
- ▶ Motor: 1HP
- ▶ Insert: SPUN1203 x 6 pcs
- ▶ Accessory: Side End Mill $\varnothing 63\text{mm} \times \varnothing 17\text{mm} \times 15\text{mm}$
- ▶ Machine Size: 500mm x 350mm x 320mm

Specify voltage when ordering.

Order No.	Model	Capability	Bevel Angle	Motor	Voltage	N.W./G.W. Pack Size
69110-110-1	GA500	0~3mm	15°~45°	1HP 3500RPM	110V,50/60Hz,1PH	26kgs/29kgs 55cmx42cmx32cm
69110-220-1					220V,50/60Hz,1PH	
69110-220-3					220V,50/60Hz,3PH	
69110-380-3					380V,50/60Hz,3PH	

69120
GAQ500
Side Mill Type C&R Dual Angle Chamfering Machine

Optional:

Features:

- ▶ Apply Side End Milling concept with rapid shifting inserts (6 pcs)
- ▶ Suitable for steel, cast iron and hardened parts.
- ▶ Adjustable cutting point of C angle to make the full using side of blade.
- ▶ Optional inverter (3500 ~ 12000 r.p.m.) for smooth surface after chamfered.
- ▶ Optional Accessory: R side mill cutter and R2/R3/R5 Blade.
- ▶ Railway spec.: 500mm x 100mm x 12mm
500mm x 40mm x 12mm
- ▶ Motor: 1HP
- ▶ Insert: SPUN1203 x 6 pcs
- ▶ Accessory: Side End Mill $\varnothing 63\text{mm} \times \varnothing 17\text{mm} \times 15\text{mm}$
- ▶ Machine Size: 500mm x 350mm x 320mm

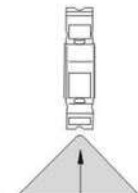
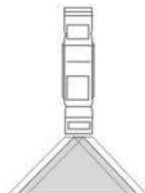
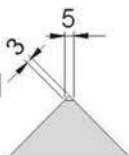
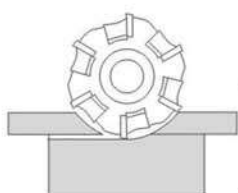

0~3C

0~3C

R2~R5

Specify voltage when ordering.

Order No.	Model	Capability	Bevel Angle	Motor	Voltage	N.W./G.W. Pack Size
69120-110-1	GAQ500	0~3mm & 2R,3R,5R	45°	1HP/3500RPM 0~12000RPM (optional)	110V,50/60Hz,1PH	28kgs/31kgs 55cmx42cmx32cm
69120-220-1					220V,50/60Hz,1PH	
69120-220-3					220V,50/60Hz,3PH	
69120-380-3					380V,50/60Hz,3PH	



69130

GDF500

Multi-function Chamfering Machine



Features:

- ▶ V slide way design for both bowl wheel and face cutter.
- ▶ Swivel work table enable more effective on blade usage.
- ▶ All kinds material are suitable.
- ▶ Beveling angle is 45°.
- ▶ Guide Rail spec.: 500mm x 100mm x 12mm
500mm x 40mm x 12mm
- ▶ Insert: SEKN1203 x 5 pcs
- ▶ Accessory: End Mill: $\varnothing 50\text{mm} \times \varnothing 17\text{mm} \times 35\text{mm}$
- ▶ Bowl Wheel: $\varnothing 100\text{mm} \times \varnothing 17\text{mm} \times 50\text{mm}$
(WA60, K5, VA6)
- ▶ Machine Size: 500mm x 420mm x 350mm

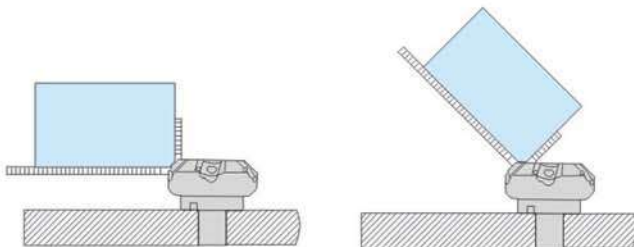

OPTIONAL

69135-01	BOWL WHEEL $\varnothing 100\text{x} \varnothing 17\text{x} 50\text{mm}$
69135-02	FACE MILL HEAD SET $\varnothing 45\text{x} \varnothing 17\text{x} 35\text{mm}$
69135-03	INSERTS(10pc/SET) SEKN1203
69135-04	CLAMP FOR INSERTS ON MILL HEAD(5pc/SET)
69135-05	SCREW FOR INSERTS ON MILL HEAD(5pc/SET)

Specify voltage when ordering.

Order No.	Model	Capability	Bevel Angle	Motor	Voltage	N.W./G.W. Pack Size
69130-110-1	GDF500	0~3mm	45°	1HP 3500RPM	110V,50/60Hz,1PH	32kgs/36kgs 55cmx44cmx38cm
69130-220-1					220V,50/60Hz,1PH	
69130-220-3					220V,50/60Hz,3PH	
69130-380-3					380V,50/60Hz,3PH	

69140 GAG500 Universal Face Mill Chamfering Machine



Features:

- ▶ Adopt with the face mill cutting and capable for all materials.
- ▶ Bevel angle 45° after chamfered.
- ▶ The T-slot table (Fig. 1) enable customer to make fixture to avoid any scratching. Also, to move up and down for chamfering the T workpeiece by track(Fig. 2)
- ▶ CE version is available.
- ▶ Standard accessory:
Face milling cutter: $\varnothing 45\text{mm} \times \varnothing 17\text{mm} \times 35\text{mm}$
Inserts:SEKN 1203(5pcs)
- ▶ Optional Diamond wheel & Abrasive Cloth Wheel require machine design change, price may varied based on options.

69142 GAG500A Slider table type (prevent scratches)

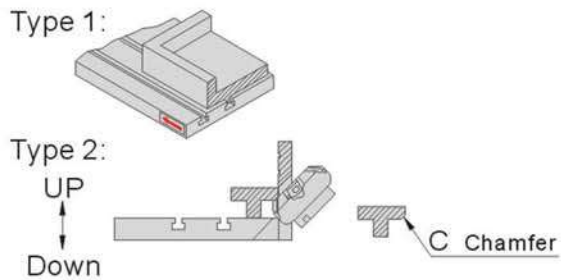

Optional:



Abrasive cloth Wheel 4"



OPTIONAL

69142	SLIDER TYPE TABLE(GAG500A)
69145-01	DIAMOND WHEEL $\varnothing 60 \times \varnothing 17\text{mm}$
69145-02	4" ABRASIVE CLOTH WHEEL $\varnothing 100 \times \varnothing 16\text{mm}$
69145-03	FACE MILL HEAD SET $\varnothing 45 \times \varnothing 17 \times \text{H}35\text{mm}$
69145-04	INSERTS(10pc/SET)SEKN1203
69145-05	CLAMP FOR INSERTS ON MILL HEAD(5pc/SET)
69145-06	SCREW FOR INSERTS ON MILL HEAD(5pc/SET)

Specify voltage when ordering.

Order No.	Model	Capability	Range	Speed	Voltage	N.W./G.W. Pack Size
69140-110-1	GAG500	0~4mm	45°	1HP 3500RPM	110V, 50Hz/60Hz, 1PH	48.5kgs/58kgs 50cmx60cmx40cm
69140-220-1					220V, 50Hz/60Hz, 1PH	
69140-220-3					220V, 50Hz/60Hz, 3PH	
69140-380-3					380V, 50Hz/60Hz, 3PH	
69142-110-1	GAG500A	0~4mm	45°	1HP 3500RPM	110V, 50Hz/60Hz, 1PH	
69142-220-1					220V, 50Hz/60Hz, 1PH	
69142-220-3					220V, 50Hz/60Hz, 3PH	
69142-380-3					380V, 50Hz/60Hz, 3PH	



69150

GT-300A

Inverter Chamfering Machine(Regular+Irregular)

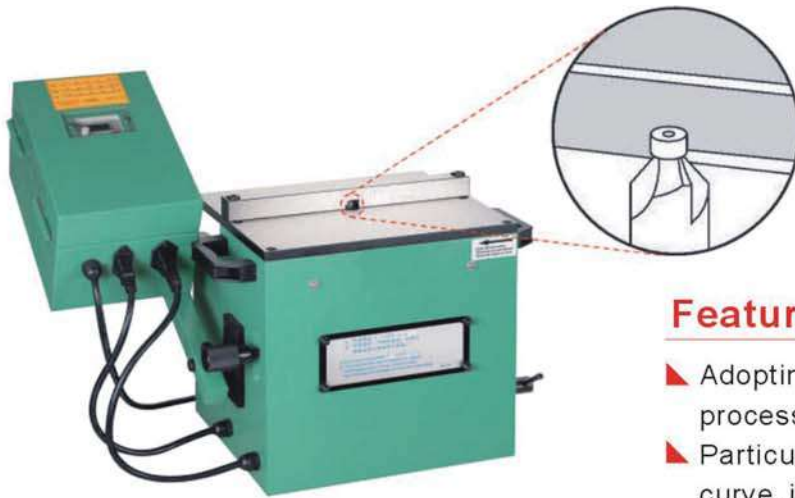

Features:

- ▶ Adopting Inverter Motor (0~12000 RPM) to processing any material (except heat treatment).
- ▶ Particularly for chamfering regular, irregular, curve, inner gap and complex of surface.
- ▶ Capable of chamfering inner gap & inner dia. min. 8mm, or radius 4R or more.
- ▶ Chamfering capability 0~2C, or 3R.
- ▶ Beveling angle is 45°.

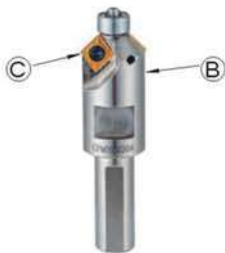

Examples:

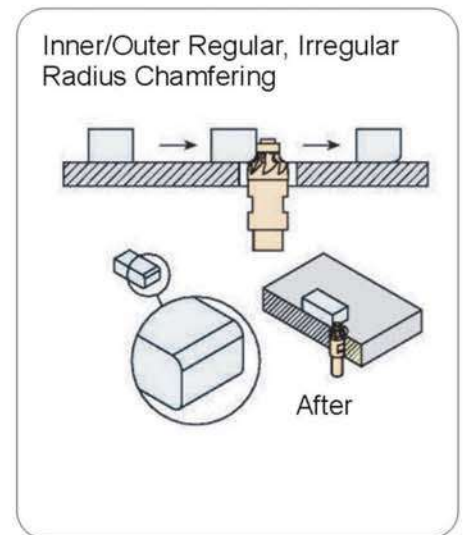
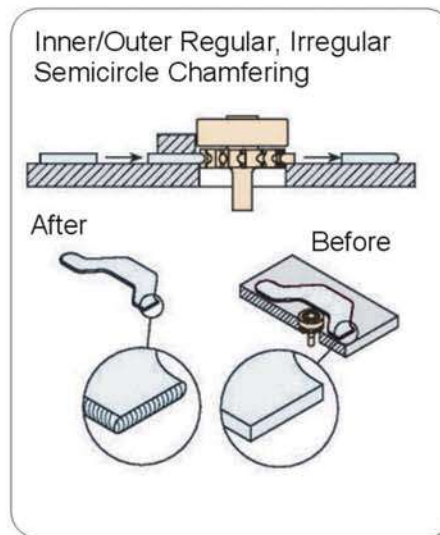
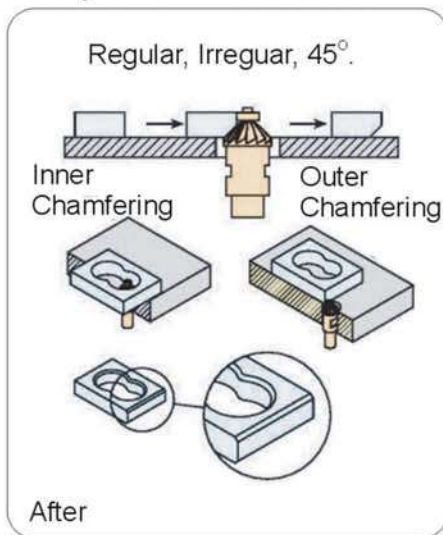

Order No.	Model	Description	Fig
69150-B	GT300A082	Replaceable Blade	(B)
69150-C	GT300A083	Blade CPMT060204(2 blades / tool)	(C)

Order No.	Model	Chamfer Angle	Track Size Size	Motor	Voltage	N.W./G.W. Pack Size
69150-110-1	GT-300A	0~3mm	300x250x12mm	1HP	110V,50/60Hz,1PH	40kgs/42kgs 55cmx44cmx38cm
69150-220-1		45°	L330xW330xH300mm	0~12000RPM	220V,50/60Hz,1PH	



Features:

- ▶ Suitable for Iron metal or non-iron metal, wooden or plastic...etc deburring purpose.
- ▶ Processing deburring with workpiece face up, easy operation and visual directly.
- ▶ Rough surface may occur if processing for general iron materials.
- ▶ Spare sand belt is available (order no. 69170-01)

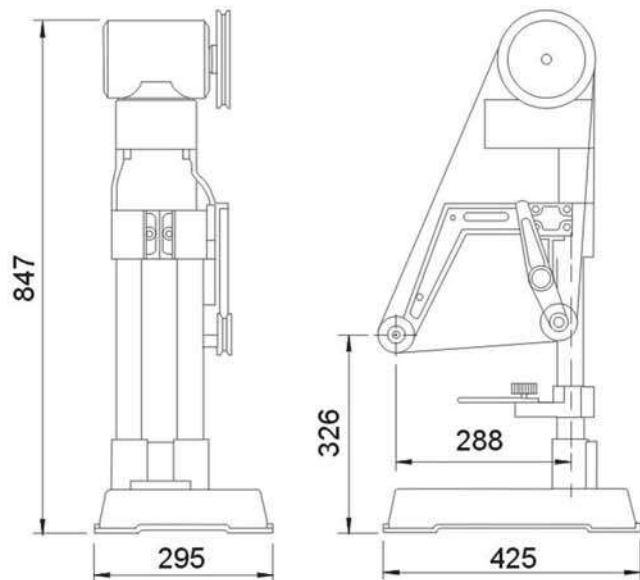

Order No.	Model	Voltage	Motor	N.W.
69170-110	GMB612-110	110V,50/60Hz 1PH	1/4HP	50kgs
69170-220	GMB612-220	220V,50/60Hz 3PH	1/4HP	

69190 GBD46A Belt and Disc Sander



Features:

- ▶ Belt tension release lever & belt tracking adjustment.
- ▶ Dust collecting system can be externally installed to keep clean in work place.
- ▶ Made of casting iron facilitate vibration generated from operation.
- ▶ Adopting powerful 450W induction motor with dust proof housing.
- ▶ Table can be used for disc or belt and be tilted to 45°.
- ▶ Voltage: 110V/220/, 50HZ/60HZ

Standard Accessory



Package

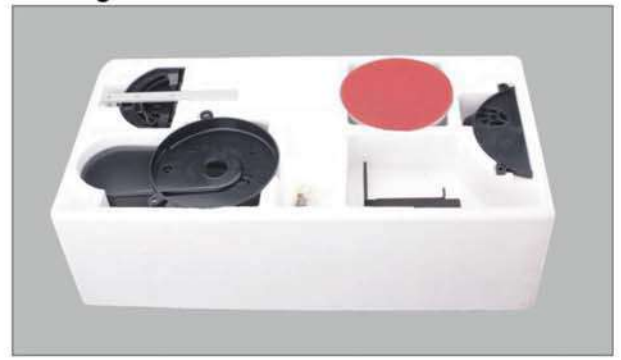

Specify voltage when ordering.

Order No.	Model	Belt		Disc		Table		Belt Angle	Motor	N.W.
		Spec.	Speed	Dia.	R.P.M.	Spec.	Angle			
69190	GBD46A	4x6"	537	6"	2800	6.2x8.8	0~45°	0~30°	1/3HP	23.6kg

Belt and Disc Sander Demostration

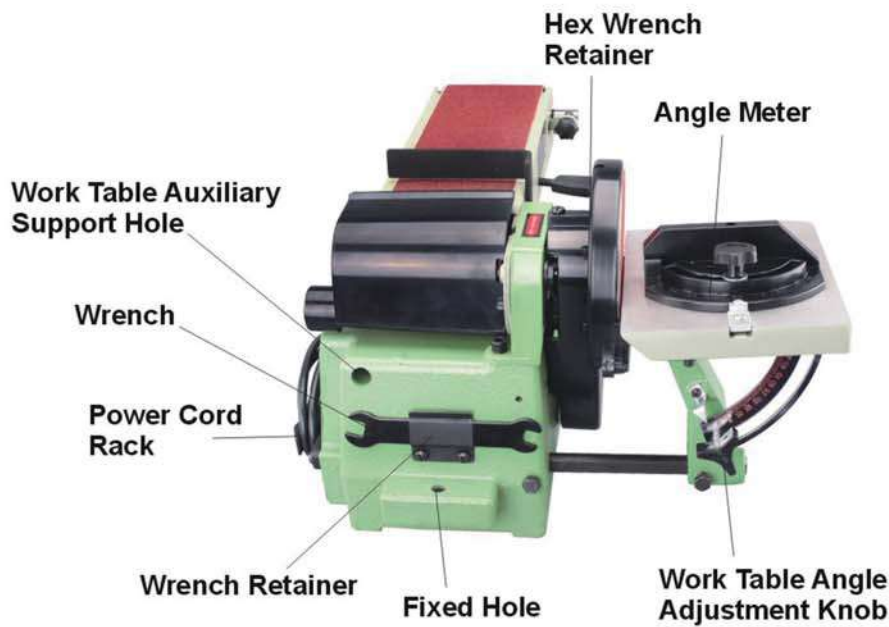

69220 GTY300/500/600 Precision Cutting & Grinding Machine

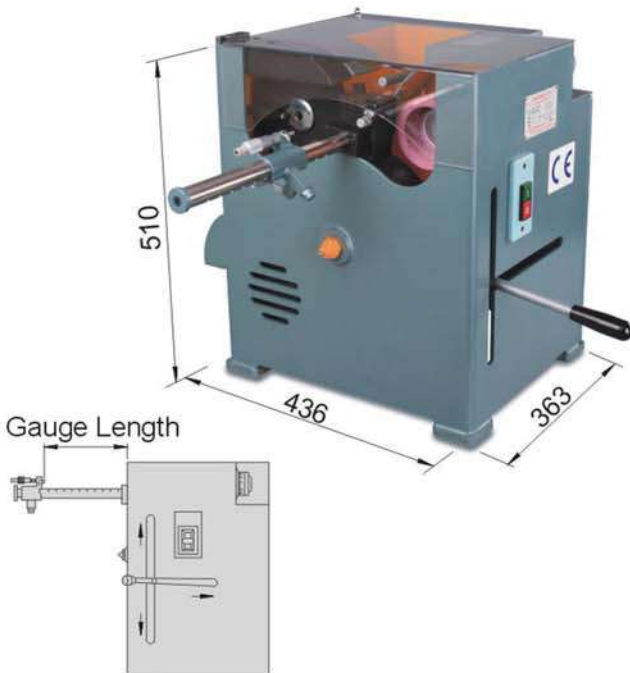

Features:

- ▶ Suitable for cutting mold, round ejector pins or stainless steel materials.
- ▶ Firstly cutting and then grinding which increase cost effectiveness.
- ▶ Quick clamp design for fast positioning and with vernier micrometer, length are set easily.
- ▶ Grinding wheel can be trimmed at anytime, wont influence the accuracy.
- ▶ High stability and high wear resistance and durability.
- ▶ End face grinding wheel spec.....#305 ϕ 100x50x20
- ▶ Cutting wheel spec.....#403 ϕ 180xT1x31.8

GTY300/500/600 have same size in machine only differ in gauge length.

Unit:mm

Order No.	Model	Gauge Ruler Length	Accuracy		R.P.M	Voltage	N.W. (Kg)
			Cutting	Sqaureness			
69220-01	GTY300x110V	300	ϕ 25x300 \pm 0.01	ϕ 25x90° \pm 0.01	3600	3/4HP 110V 1PH	87.5
69220-02	GTY300x110V-CE	300	ϕ 25x300 \pm 0.01	ϕ 25x90° \pm 0.01	3600	3/4HP 110V-CE 1PH	87.5
69220-03	GTY300x220V	300	ϕ 25x300 \pm 0.01	ϕ 25x90° \pm 0.01	3600	3/4HP 220V 1PH	87.5
69220-04	GTY300x220V-CE	300	ϕ 25x300 \pm 0.01	ϕ 25x90° \pm 0.01	3600	3/4HP 220V-CE 1PH	87.5
69220-05	GTY300x380V	300	ϕ 25x300 \pm 0.01	ϕ 25x90° \pm 0.01	3600	3/4HP 380V	87.5
69220-06	GTY300x380V-CE	300	ϕ 25x300 \pm 0.01	ϕ 25x90° \pm 0.01	3600	3/4HP 380V-CE	87.5
69220-07	GTY500x110V	500	ϕ 25x300 \pm 0.02	ϕ 25x90° \pm 0.02	3600	3/4HP 110V 1PH	91.5
69220-08	GTY500x110V-CE	500	ϕ 25x300 \pm 0.02	ϕ 25x90° \pm 0.02	3600	3/4HP 110V-CE 1PH	91.5
69220-09	GTY500x220V	500	ϕ 25x300 \pm 0.02	ϕ 25x90° \pm 0.02	3600	3/4HP 220V 1PH	91.5
69220-10	GTY500x220V-CE	500	ϕ 25x300 \pm 0.02	ϕ 25x90° \pm 0.02	3600	3/4HP 220V-CE 1PH	91.5
69220-11	GTY500x380V	500	ϕ 25x300 \pm 0.02	ϕ 25x90° \pm 0.02	3600	3/4HP 380V	91.5
69220-12	GTY500x380V-CE	500	ϕ 25x300 \pm 0.02	ϕ 25x90° \pm 0.02	3600	3/4HP 380V-CE	91.5
69220-13	GTY600x110V	600	ϕ 25x300 \pm 0.03	ϕ 25x90° \pm 0.03	3600	3/4HP 110V 1PH	93.5
69220-14	GTY600x110V-CE	600	ϕ 25x300 \pm 0.03	ϕ 25x90° \pm 0.03	3600	3/4HP 110V-CE 1PH	93.5
69220-15	GTY600x220V	600	ϕ 25x300 \pm 0.03	ϕ 25x90° \pm 0.03	3600	3/4HP 220V 1PH	93.5
69220-16	GTY600x220V-CE	600	ϕ 25x300 \pm 0.03	ϕ 25x90° \pm 0.03	3600	3/4HP 220V-CE 1PH	93.5
69220-17	GTY600x380V	600	ϕ 25x300 \pm 0.03	ϕ 25x90° \pm 0.03	3600	3/4HP 380V	93.5
69220-18	GTY600x380V-CE	600	ϕ 25x300 \pm 0.03	ϕ 25x90° \pm 0.03	3600	3/4HP 380V-CE	93.5

GE:CE Marking

69220

GTY300/500/600

Precision Cutting & Grinding Machine



Cutting demo



Clamping demo

Order No. 69220-A



End face grinding wheel
Cutting wheel



Fine-tuning feeding



Driven belt

Order No. 69220-B



End face grinding wheel
Cutting wheel



Clamping lever

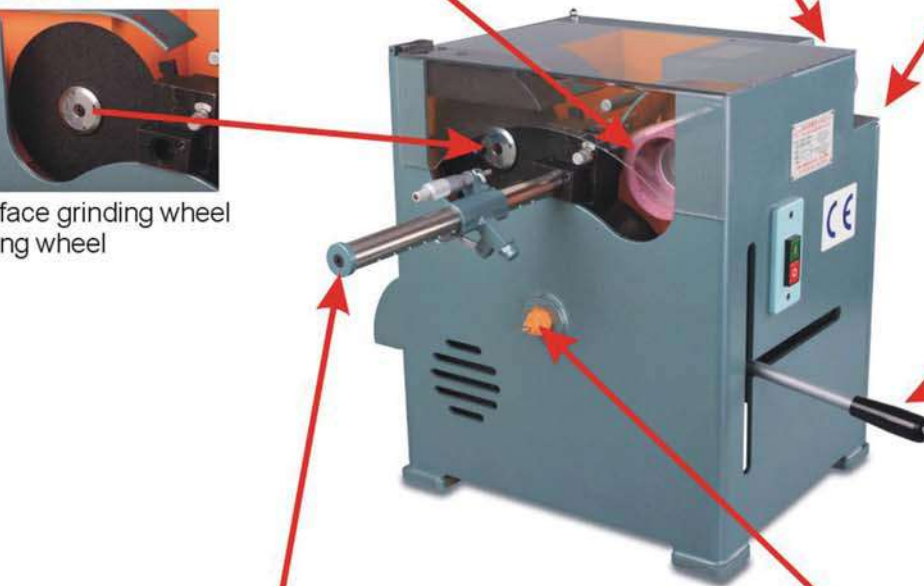

Gauge Ruler



Lubrication nozzle

Features:

- ▶ Suitable for precision cutting of tungsten steel and special steel and end face with no burrs.
- ▶ Manually feeding and clamping.
- ▶ Easy operation and safety.
- ▶ Wheel replacement is simple.
- ▶ Diamond wheel and cuttable linear rail are optional.



Fixture holding stability.



GTY732 Precision Cutting-off Instruction Demo

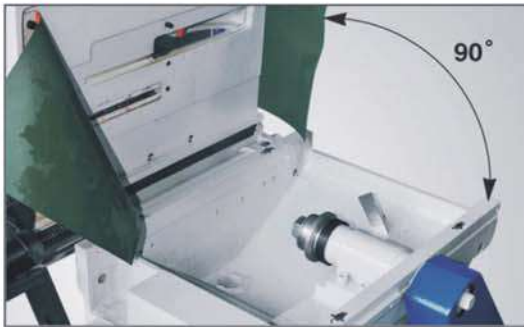

Easy maintenance

The cleaning and maintenance of this machine is extremely convenient.
Wheel replacement is quick and easy.



Setup device

Provide convenient and fast workpiece length setting.
With a fine adjustment knob.



Manually feeding and clamping.

The table feed is operated by handwheel.
The clamping are by handles.

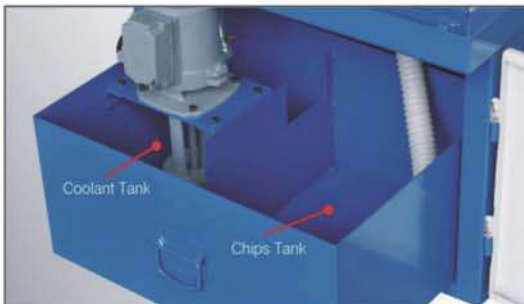

Coolant and chips tanks.

It is designed to build-in the bottom case of the machine which saves spaces and look nice.

Unit:mm

Order No.	69222-220-3	69222-380-3
Model	GTY732	
Max. Cutting range	W100mmx ϕ 25mm	
Cutting wheel spec.	ϕ 150mmxI.D.9.05mm	
Cutting accuracy	20 \pm 0.1	
Coolant pump	1/8HP	
Speed	4000RPM	
Power	220V 3 ϕ 50/60Hz 2HP	380V 3 ϕ 50/60Hz 2HP
Scale ruler	300mm	
N.W./G.W.	130/150kg	
Machine size	870x900x1230mm	
Package size	970x970x1380mm	



Precision Machinery

69224

GTU280

High Speed Cutting-off Machine



Features:

- ▶ Suitable for precision cutting of mold ejector pins or rod bar or stainless steel materials and end face with no burrs.
- ▶ Manually feeding and clamping.
- ▶ Easy operation and safety.
- ▶ Wheel replacement is simple.
- ▶ Low vibration and less dust during operation.



V shape clamping for round workpiece



Set zero before usage



Easy replacement
(standard wheel $\varnothing 150 \times 19.05 \text{mm}$)

Unit:mm

Order No.	69224-110	69224-220
Model	GTU280-110	GTU280-220
Max. Cutting capacity	$\varnothing 25 \text{mm}$ 100mm(width)	
Cutting accuracy	20 ± 0.1	
Cutting wheel spec.	O.D. 150xI.D. 19.05x1	
Power	1/2HP 110V 1 ϕ	1/2HP 220V 1 ϕ
R.P.M.	3600	
Gauge Ruler Length	300	
N.W. / G.W.	85/97kgs	
Machine size	620x550x450mm	
Package size	690x530x780mm	

69228

GTY130

High Speed Cutting-off Machine



Features:

- ▶ Suitable for cutting carbide, HSS, or other materials.
- ▶ Compact design with X & Y axis movable structure which increase the accuracy of cutting performance.
- ▶ Cutting capacity from $\varnothing 3\sim 16\text{mm}$ with max. length 15mm.
- ▶ Radius cutting by dual-motor drivers, workpiece is also rotating at the same time which increases cutting efficiency.
- ▶ Natural dry cooling which is enabled by connecting with compressor air or vacuum cleaner to achieve perfect cooling effect.
- ▶ Quick work-change thanks to the high quality 3-Jaw chuck clamping.

Standard accessories



SDC#100(100mm)
(For carbide)1pcs

69228-01



E60WA(100mm)5pcs

69228-02



CBN#100(100mm)
(For HSS)1pcs

69228-03



Optional accessories:
Grinding wheel SDC#100
width 5 or 10mm for carbide
Grinding wheel CBN#100
width 5 or 10mm for HSS



Cutting carbide end mill performance
 $\varnothing 10$ end mill takes approx. 55 seconds
 $\varnothing 16$ end mill takes approx. 100 seconds



Cutting HSS end mill performance
 $\varnothing 10$ end mill takes approx. 60 seconds
 $\varnothing 16$ end mill takes approx. 110 seconds

Unit:mm

Order No.	69228-110	69228-220
Model	GTY130	
Max. Cutting capacity	$\varnothing 3\text{mm}\sim 16\text{mm}$	
Power	110V 50/60Hz 1 ϕ	220V 50/60Hz 1 ϕ
R.P.M.	5300	
Motor	150W	
N.W.	27.5kgs	
Machine size	380x230x220mm	
Package size	480x320x330mm	



PRECISION MACHINERY

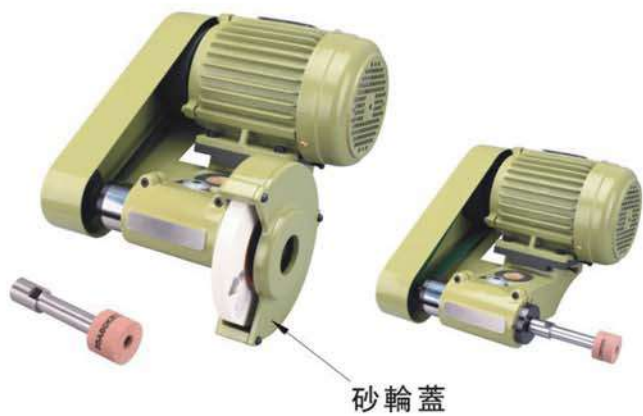

砂輪蓋

標準附件

1. 平面皮帶
2. 內徑研磨心軸
3. 砂輪修整器
4. 鑽石修刀
5. 砂輪平衡校正軸
6. 取出螺栓
7. 皮帶輪
8. 六角扳手

特殊附件

9. 砂輪平衡校正臺
10. 彈性夾頭及夾具
11. 砂輪法蘭盤
12. 深孔研磨主軸

※ 零件部品詳細圖

多功能研磨主軸

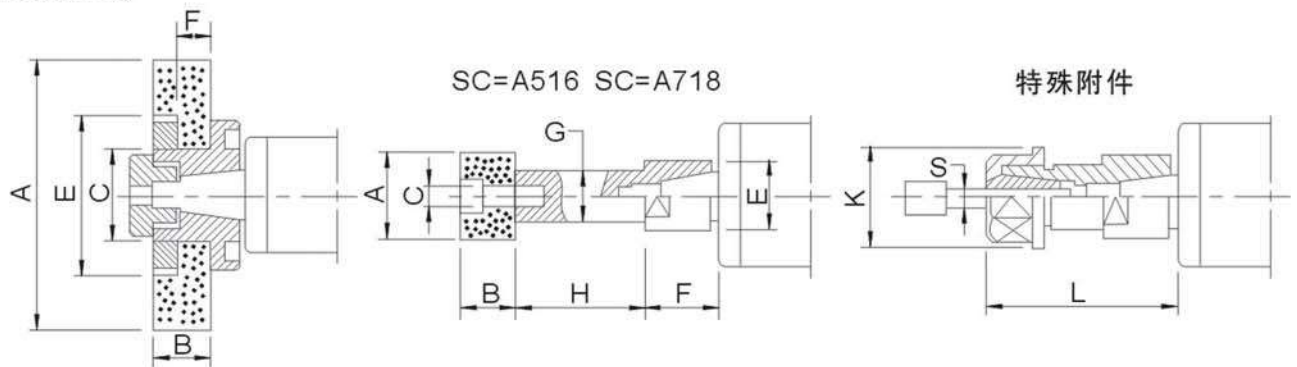

特點:

- ▲ 機座及中心調整座使用高級鑄鐵，經精密研磨及鍍花處理，主軸中心高度可作精確調整。
- ▲ 馬達及皮帶輪經精密平衡校正，回轉穩定。
- ▲ 研磨主軸使用合金鋼，經熱處理后研磨，配合高速精密軸承組合，剛性優良，精度0.002以內，連續運轉三小時以上，溫升15°以內。
- ▲ 主軸端為砂輪法蘭盤及內徑研磨心軸互換型，可作外徑研磨及多種尺寸之內徑研磨。
- ▲ 主要用途可配合傳統車床，固定于換刀座作研磨加工外徑及內徑使用。

內徑研磨



外徑研磨

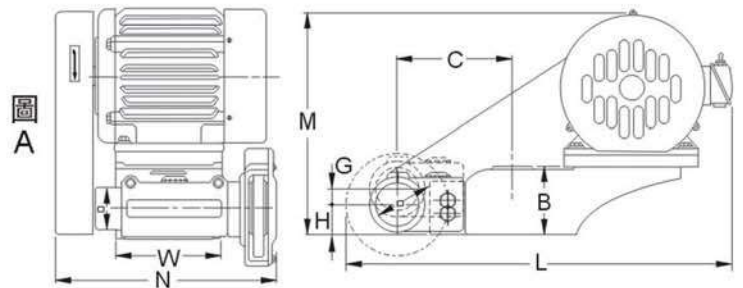

型號 Model	外徑研磨砂輪尺寸表					型號 Model	內徑研磨砂輪軸尺寸表						型號 Model	夾小徑筒夾尺寸			
	A	B	C	E	F		A	B	C	G	H	E		F	L	K	S
SC-55	125	19	41.28	70	10	A512	14	16	4	9	40	20	25				
SC-107	180	19	31.75	100	13	*A516	25	16	6	16	55	20	25	C-58	60	28	3-8
SC-210	255	25	101.6	-	-	A520	38	20	8	20	55	24	25				
SC-312	305	25	101.6	-	-	A712	20	16	6	12	40	24	32	C-70	75	28	3-10
SC-514	350	38	127	-	-	*A718	38	20	8	18	68	24	32				
						A724	50	20	10	24	60	30	32				

上表格打*號為標準配件，其他供參考選購。

特殊附件:深孔研磨主軸表格供參考選購

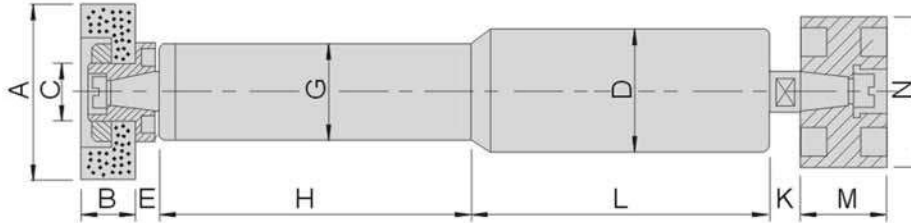

型號 Model	Housing		Dimensions				Grinding wheel			Pulley		Max.speed min-1
	D	L	G	H	E	K	A	B	C	M	N	
G-504 G-505	50	170	42 50	200 250	12	15	60 75	20	25 25	34	58 70	8000 6600
G-604 G-605 G-606	60	180	42 50 60	200 250 300	12	15	60 75 100	20	25 25 31.75	40	58 70 90	8000 6600 5200
G-805 G-806	80	250	70 80	250 300	13 15	20	125 180	20	31.75 31.75	50	68 68	4000 3000

單位:mm

訂購編號 Order No.	型號 Model	馬達		外徑研磨			內徑研磨			適用車床	請對照J19頁A圖								重量 (kg)		
		馬力 HP	電壓	砂輪尺寸 外徑x厚x孔徑 (mm)	無負荷速度 (R.P.M.)		砂輪尺寸 外徑x厚x孔徑 (mm)	無負荷速度 (R.P.M.)			研磨深度	C	D	H	G	B	W	L		M	N
					60HZ	50HZ		60HZ	50HZ												
69242-01	GDE55x220V	1/2	220V 三相	125x19x41.27	4500	3750	25x16x6	23000	19000	90	13°-20°	90	50	40	10	75	102	440	240	290	26
69242-02	GDE55x380V	1/2	380V 三相																		
69242-03	GDE55x415V	1/2	415V 三相																		
69242-04	GDE55x440V	1/2	440V 三相																		
69242-05	GDE107x220V	1	220V 三相	180x19x31.75	3300	2750	25x16x6	18000	16800	110	18°-30°	100	60	40	10	75	102	485	270	300	38
69242-06	GDE107x380V	1	380V 三相																		
69242-07	GDE107x415V	1	415V 三相																		
69242-08	GDE107x440V	1	440V 三相																		
69242-09	GDE210x220V	2	220V 三相	250x25x101.6	2320	1930	25x16x6	--	--	--	20°-32°	80	80	56	0	115	150	455	360	370	62
69242-10	GDE210x380V	2	380V 三相																		
69242-11	GDE210x415V	2	415V 三相																		
69242-12	GDE210x440V	2	440V 三相																		
69242-13	GDE312x220V	3	220V 三相	305x25x101.6	1920	1600	25x16x6	--	--	--	20°-32°	80	80	56	0	115	150	480	380	385	75
69242-14	GDE312x380V	3	380V 三相																		
69242-15	GDE312x415V	3	415V 三相																		
69242-16	GDE312x440V	3	440V 三相																		
69242-17	GDE514x220V	5	220V 三相	350x38x127	1580	1310	25x16x6	--	--	--	30°以上	120	100	75	0	150	200	560	470	500	160
69242-18	GDE514x380V	5	380V 三相																		
69242-19	GDE514x415V	5	415V 三相																		
69242-20	GDE514x440V	5	440V 三相																		



69246 U2 Universal Grinding for Cutters



N.W. 45kg

Features:

- ▶ Suitable for grinding HSS and carbide engraving cutter as well as single lip or multiple lip cutters of various shapes such as radius cutters or negative taper angle of cutters .
- ▶ The universal index head has 24 fast indexing (each 15°) and free 360° is also achievable.
- ▶ Optional accessories enable the device for grinding End Mills, Twist Drill and Lathe cutters, with simplicity installation.

Order No.	Model	Power	Motor
69246-220-1	U2	220V,50/60Hz 1PH	1/3HP
69246-220-3		220V,50/60Hz 3PH	
69246-380-3		380V,50/60Hz 3PH	

Subject to change of colour painting on parts without notice.

Specifications:

Max. Clamping: $\varnothing 18\text{mm}$
 Max. Grinding dia. $\varnothing 25\text{mm}$
 Taper angle $0^\circ - 180^\circ$
 Relief angle $0^\circ - 45^\circ$
 Negative angle $0^\circ - 26^\circ$
 Spindle Speed 3600 r.p.m.
 Bowl grinding wheel 100x50x20mm
 Machine size L450 x W400 x H350mm

Standard Accessories:

Diamond dresser with diamond...1pc
 Flange (mounted)...1pc
 Bowl grinding wheel 100x50x20mm
 Collets $\varnothing 4,6,8,10,12\text{mm}$...5pc
 Aligning Flinger...1pc
 Drive Belt ...1pc
 Lock pin...1pc
 Wrench & spanner...1set

Optional Accessories:

Twist drill grinding attachment
 END mill grinding attachment
 Lathe tool grinding attachment
 Grinding wheel Balancing Stand
 Grinding Wheel
 Collets: $\varnothing 1, 2, 3, 5, 7, 9, 18, 20, 25\text{mm}$
 $\varnothing 1/8", 3/16", 1/4", 5/16", 3/8", 1/2", 5/8"$
 Milling Collet: $\varnothing 20, 25\text{mm}$
 Tool Cabinet

<p>Collets 1: $\varnothing 1.5 \sim \varnothing 16$</p>	<p>End mill grinding attachment</p> <p>(Order no.: 69246-04)</p>	<p>Twist drill grinding attachment</p> <p>(Order no.: 69246-03)</p>
<p>Collets 2: $\varnothing 18 \sim \varnothing 25$</p>	<p>Lathe cutter grinding attachment</p> <p>(Order no.: 69246-05)</p>	<p>Diamond wheel</p> <p>Resinoid and CBN wheel</p> <p>(Order no.: 69246-01 69246-02)</p>

69248 GAP312 End Mill Grinder

Patent: ZL201820641893.1



Features:

- ▶ Capable of grinding 2, 3, & 4-flute hard alloy or HSS end mills.
- ▶ One-piece aluminium body compact design, reduce vibration when operating.
- ▶ User friendly and high cost effectiveness, operation can be done in 1 min.
- ▶ Easy to presetting, feeding can be set and perform accuracy within 0.01mm.



2-flute



3-flute



4-flute

Order No.	69248-01-110-1	69248-01-220-1
Model	GAP312	
Applicable mill diameter	ø3~12mm	
Applicable number of mill flutes	2, 3, 4	
Grinding angle of the end of the mill	Mill pitch 7°, rake angle 20°, relief angle 30°	
Power supply	110V, 50/60Hz, 1HP	220V, 50/60Hz, 1HP
Motor output power	450W	
Rotating speed	7000RPM, 9000RPM	
Overall dimensions	245mm x 245mm x 260mm	
Weight	12.5kgs	

Accessories:



HSS



Collet x 7pcs



2-flute collet fixture x 7pcs



3-flute collet fixture x 7pcs



4-flute collet fixture x 7pcs

(Order no.: 69248-01 SDC#220)



Front view



2. Operating Instructions

- 1) Put the end mill into the corresponding mill collet, expose the end mill head for about 15~20mm, lock the collet screw to secure the end mill with the collet.
- 2) Put the collet into the corresponding fixture, place the fixture into the aligner all the way with the screw hole facing up, and start the alignment.



- 3) When aligning the 4-flute end mill, turn the end mill adjustment knob counterclockwise to the leftmost position, turn the collet clockwise to make the primary end mill edge in contact with the end mill adjustment plate, and adjust the length of the cutter by the length adjustment knob.
- 4) Lock the fastening screw of the collet to secure the collect(do not use excess torque when fastening in order not to damage the surface of the collet fixture.)
- 5) Turn the end mill adjustment knob clockwise to the rightmost position and remove the collet fixture with the end mill aligned.
- 6) When aligning the 3-flute end mill, put the mill into the corresponding end mill collet, and expose the end mill head for about 15~20mm.
- 7) Put the collet into the corresponding fixture, place the fixture into the aligner all the way with the screw hole facing up, and start the alignment.
- 8) Turn the mill adjustment knob counterclockwise to the leftmost position, make the primary end mill edge in contact with the end mill adjustment plate against the block on the right side, lock the collet fixing screw to secure the collect, and turn the end mill adjustment knob clockwise to the rightmost position and remove the collet fixture with the mill aligned.
- 9) When aligning the 2-flute end mill, put the end mill into the corresponding end mill collet, expose the end mill head for about 15~20mm, and ock the collet screw to secure the end mill with the collet.
- 10) Put the collet into the corresponding fixture, place the fixture into the aligner all the way with the screw hole facing up, and start the alignment.

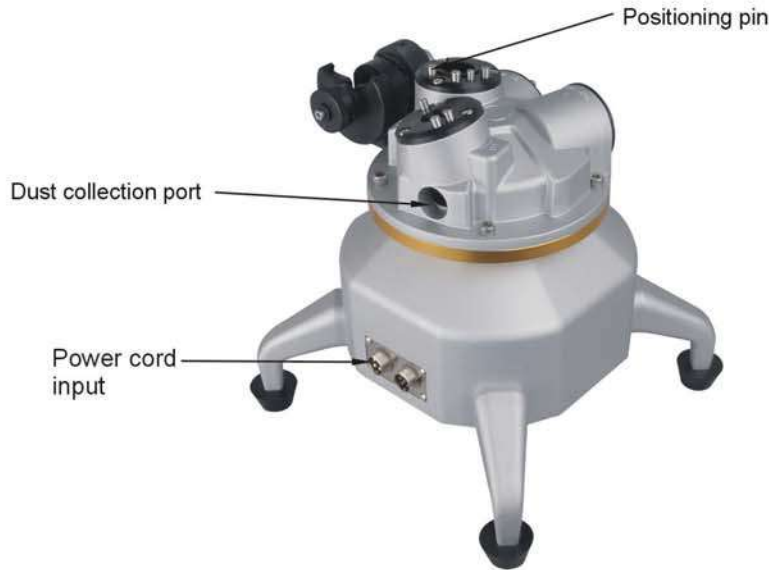

Rear view

- 11) Turn the end mill adjustment knob counterclockwise to the leftmost position, make the primary end mill edge in contact with the end mill adjustment plate, lock the collet fixing screw to secure the collect, and turn the end mill adjustment knob clockwise to the rightmost position and remove the collet fixture with the end mill aligned.

- 12) Turn on the equipment switch, plug in the controller cable, and start grinding.

- 13) Grinding of the rake angle: place the fixture into the grinding port for the rake angle. Cutters with a diameter of 2 ~ 5 shall be placed in the grinding port of $\varnothing 2 \sim \varnothing 5$ for the rake angle. Cutters with a diameter of 6~12 shall be placed in the grinding port of $\varnothing 6 \sim \varnothing 12$ for the rake angle.

 Grinding the rake for $\varnothing 6 \sim \varnothing 12$ end mill

When installing the fixture into the grinding port for the rake angle, the extrusion of the fixture should be under the positioning pin. In the case of 2-flute fixtures, rotate 180° for the other rake angle; In the case of 3-flute fixtures, rotate 120° twice for the other two rake angles; In the case of 4-flute fixtures, rotate 90° three times for the other three rake angles. Move the fixture back and forth horizontally and keep the mill in close contact with the diamond wheel at all time. The diamond wheel rotating at high speed shall grind the cutting edge.

- 14) Grinding of the pitch: when installing the fixture into the grinding port for the rake angle, the extrusion of the fixture should be under the positioning pin. In the case of 2-flute fixtures, rotate 180° for the other rake angle; In the case of 3-flute fixtures, rotate 120° twice for the other two rake angles; In the case of 4-flute fixtures, rotate 90° three times for the other three rake angles. Move the fixture back and forth horizontally and keep the mill in close contact with the diamond wheel at all time. The diamond wheel rotating at high speed shall grind the cutting edge.



Grinding the end mill pitch

- 15) Grinding of the relief angle: when installing the fixture into the grinding port for the rake angle, the extrusion of the fixture should be under the positioning pin. In the case of 2-flute fixtures, rotate 180° for the other relief angle; In the case of 3-flute fixtures, rotate 120° twice for the other two relief angles; In the case of 4-flute fixtures, rotate 90° three times for the other three relief angles.



Grinding the relief angle

- 16) After the grinding is complete, switch off the equipment.



69249

GS213

端銑刀研磨機 End Mill Re-sharpening Machine



特點:

- ▲ 超機動性:攜帶方便。
- ▲ 鑽石砂輪片設計,堅固耐用。
- ▲ 研磨刀刃可過中心,操作簡單。
- ▲ 精度極高公差0.02mm,屬高精密型。
- ▲ 適合NC銑床, CNC銑床加工中心機所使用的鈷鋼端銑刀的研磨再生。

端銑刀:可研磨直徑 $\phi 3\text{mm}\sim 12\text{mm}$ 端面角度可調整,刀刃寬度亦可調整。

CBN#200高速鋼用(HSS) 訂購編號:69249-A(選配)

SDC#200鈷鋼用 訂購編號:69249-B(標配),
異徑銑刀可選購異徑筒夾。

訂購編號 Order No.	型號 Model	銑刀直徑	電源	機器尺寸 包裝尺寸	淨重 毛重
69249-110-1	GS213	$\phi 3\sim 12\text{mm}$	110V,50/60Hz單相	240x240x250mm	12kgs
69249-220-1			220V,50/60Hz單相	410x310x390mm	14kgs

69249-00

GSD213

鑽頭及端銑刀複合研磨機

Twist Drill And End Mill Re-sharpening Machine

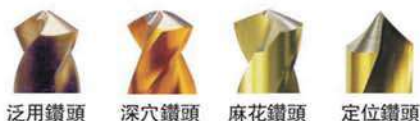

泛用鑽頭 深穴鑽頭 麻花鑽頭 定位鑽頭

特點:

- ▲ 提供鑽頭和端銑刀的研磨使用,為兩機一體。
- ▲ 提供了方便性,不占空間。
- ▲ 攜帶方便,可任意移動异地使用。
- ▲ 具有GS213和GP0213的功能,方便了雙使用性能。

麻花鑽:可研磨直徑 $\phi 2\text{mm}\sim 13\text{mm}$ 標配:CBN#200
(右側) 選配:SDC#200。先端角可調整 $90^\circ\sim 140^\circ$

端銑刀:可研磨直徑 $\phi 3\text{mm}\sim 12\text{mm}$ 標配:SDC#200
(左側) 選配:CBN#200。端面角度可調整,刀刃寬度亦可調整

CBN#200高速鋼用(HSS) 訂購編號:69249-A

SDC#200鈷鋼用 訂購編號:69249-B

異徑銑刀可選購異徑筒夾(銑刀柄筒夾)可選購。

訂購編號 Order No.	型號 Model	鑽頭直徑	先端角	銑刀直徑	電源	機器尺寸 包裝尺寸	淨重 毛重
69249-00-110-1	GSD213	$\phi 2\sim 13\text{mm}$	$90^\circ\sim 140^\circ$	$\phi 3\sim 12\text{mm}$	110V,50/60Hz單相	310x240x280mm	15kgs
69249-00-220-1					220V,50/60Hz單相	410x300x400mm	17kgs

69249-01/02
GAS312/1026
端銑刀研磨機 End Mill Re-sharpening Machine

**69249-01
GAS312**
**69249-02
GAS1026**

特點:

- ▶ 無與倫比:操作簡單、研磨精確、經濟實惠。
- ▶ 超機動性:便攜式設計,攜帶方便。
- ▶ 極致效能:鑽石砂輪片設計,堅固耐用,壽命極長。
- ▶ 貼心設計:隱藏式設計,方便管理。
- ▶ 研磨刀刃過中心,操作簡單不須技術。
公差0.02mm。
- ▶ 適用產業: NC銑床、CNC銑床加工中心機。

標準附件GAS312

SD200A(3.0~5.0mm) **69249-A**
SD200B(5.1~8.0mm) **69249-B**
SD200C(8.1~12.0mm) **69249-C**
SD200F **69249-D**

2刃用夾頭組 3刃用夾頭組 4刃用夾頭組 偏心襯套

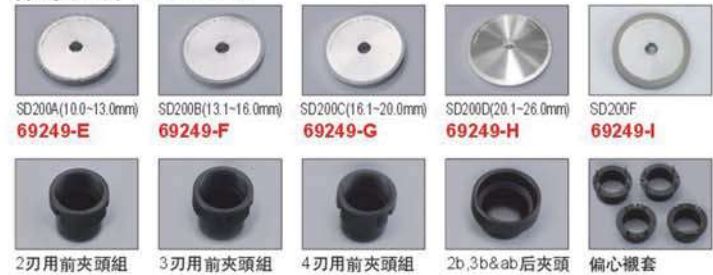
標準附件GAS1026

SD200A(10.0~13.0mm) **69249-E**
SD200B(13.1~16.0mm) **69249-F**
SD200C(16.1~20.0mm) **69249-G**
SD200D(20.1~26.0mm) **69249-H**
SD200F **69249-I**

2刃用前夾頭組 3刃用前夾頭組 4刃用前夾頭組 2b,3b&ab后夾頭 偏心襯套

訂購編號 Order No.	69249-01-110-1	69249-01-220-1	69249-02-110-1	69249-02-220-1
型號 Model	GAS312		GAS1026	
銑刀直徑	∅3~12mm		∅10~26mm	
先端角	0°, 3°, 7°, 12°		0°, 3°, 7°	
電源	110V, 50/60Hz 單相	220V, 50/60Hz 單相	110V, 50/60Hz 單相	220V, 50/60Hz 單相
回轉數	4500R.P.M		3280R.P.M	
鑽石砂輪	SDC#200		SDC#200	
重量	14.7kgs		27.5kgs	
機器尺寸	300x165x245mm		445x235x270mm	
包裝材積	380x245x325mm		525x315x350mm	
研磨有效長度	需超過43mm		需超過95mm	
標準配件	鑽石砂輪x1片(主砂輪:右SDC#200砂輪) x1片(左A砂輪:∅3.0~5.0mmSDC#200砂輪) x1片(左B砂輪:∅5.1~8.0mmSDC#200砂輪) x1片(左C砂輪:∅8.1~12.0mmSDC#200砂輪) 筒夾x6個(∅3,4,6,8,10,12/各一個) 夾頭組x3個(銑刀夾頭及螺帽) 六角扳手x2支(3mm,4mm)		鑽石砂輪x1片(主砂輪:右SDC#200砂輪) x1片(左A砂輪:∅10.0~13.0mmSDC#200砂輪) x1片(左B砂輪:∅13.1~16.0mmSDC#200砂輪) x1片(左C砂輪:∅16.1~20.0mmSDC#200砂輪) x1片(左D砂輪:∅20.1~26.0mmSDC#200砂輪) 筒夾x17個(∅10~26/各一個) 夾頭組x4個(夾頭及螺帽,前x3個,后x1個) 六角扳手x2支(3mm,5mm)	
選配配件	砂輪:CBN#200高速鋼用(HSS)			



69250 GH413/1225 Fast End Mill Re-sharpening



Magnified Part

Fixed Block
(Harden treatment to protect the alignment base)

Alignment Knob

Alignment Base

Alignment Block

NO.2 for screw radial angle 20°

NO.3 for cutting angle 6° this oval shaped hole allows holder unit to move on axis to grind all surface of end mill.

NO.1 for end mill flat slot angle 30°

For End Re-sharpening, 2, 3 and 4 Flutes Precision, Efficiency, Easy Operation, Short Processing Time, Grinding Diameter from **GH0413 4-13MM**, **GH1225 12-25MM**

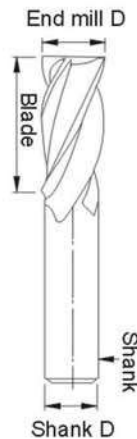

- 1. High Efficiency, High Quality Grinding Slip, Good Grinding Results.
- 2. Quality Assurance: 0.02mm
- 3. Easy Operation, and Fast for Convenience

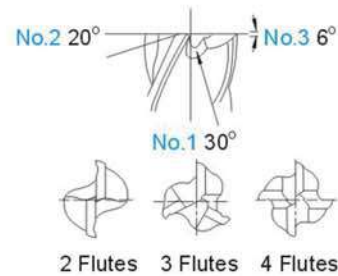

Axial angles Third angle 6° Third angle 20° Third angle 30°

Specify voltage when ordering.

Order No.	Model	Grinding Range	Voltage	Motor / Speed	Machine Size	N.W.
69250-01-110-1	GH413	4~13mm	110V,50/60Hz 1HP	450W/6000rpm	310x260x290mm	17kgs
69250-01-220-1			220V,50/60Hz 1HP			
69250-02-110-1	GH1225	12~25mm	110V,50/60Hz 1HP	1000W/4500rpm	360x290x340mm	30kgs
69250-02-220-1			220V,50/60Hz 1HP			

69250
GH413/1225
Fast End Mill Re-sharpening

2, 4 flutes

3 flutes

Refer to P.J29 for instruction manual

Axial angles	Third angle 6°	Third angle 20°	Third angle 30°
power	AC 110V / AC 220V 50 / 60 HZ		

Standard Accessories: SDC Carbide CBN High Speed

	Order No.	
Cable		1 SET
Fuse		2 PCS
Hex.key wrench		1 PCS 4mm
Diamond wheel	69250-01	GH413 SDC300#(4mm~5mm,carbide end mill)Carbide
	69250-02	GH413 SDC300#(6mm~13mm,carbide end mill)Carbide
	69250-03	GH1225 CBN150#(12mm~25mm,High Speed end mill)HSS
	69250-04	GH1225 SDC150#(12mm~25mm,carbide end mill)Carbide
ER chuck		2,4 flutes chuck *1 set & 3 flutes chuck *1 set
ER collet		GH413, 4~13mm (10pcs) / GH-1225, 12,16,18,20,22 & 25mm (6pcs)

Option Accessories:

Diamond wheel	69250-11	GH413 CBN300#(4mm~5mm,High Speed end mill)HSS
	69250-12	GH413 CBN270#(6mm~13mm,High Speed end mill)HSS
	69250-13	GH413 CBN270#(4mm~13mm,High Speed end mill)2 flutes HSS
	69250-14	GH413 SDC300#(4mm~13mm,carbide end mill)2 flutes Carbide
	69250-15	GH1225 CBN150#(12mm~25mm,High Speed end mill)2 flutes HSS
	69250-16	GH1225 SDC150#(12mm~25mm,carbide end mill)2 flutes Carbide



OPERATIONS

1. Setup the end mill to the ER collet holder

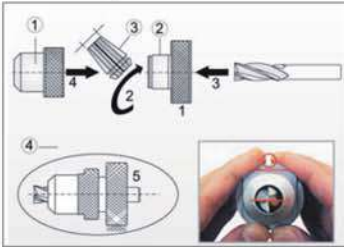

※ Please follow steps 1,2,3,4 to set up the end mill to the holder (without tightening).

1. Determine diameter and flute of your end mill, and then select the proper collet and collet holder.
2. Insert collet into collet holder and tighten nut slightly.
3. Insert end mill into collet holder and nuts out 35mm or so from the collet holder.
4. Place the flute with edge over center point and have it to be parallel with the benchmark notch.

2.-NO.1 Align end mill-NO.1



Set alignment knob to the proper number according to the diameter of the end mill. (e.x. End mill dia. 10mm, set the scale to 10mm)



※ The flute with edge over center point should be parallel with the benchmark line

3.-NO.2 Align end mill-NO.2



1. Point holder's benchmark notch at triangle mark of alignment base and insert it to the base.
2. Loosen holder, lower the holder to the base, and screw the nut clockwise. At the same time, rotate the flute with edge over center point clockwise until it touches the alignment block.
3. Tighten the ER nut until the end mill is supported but free to turn. Pull out the holder counter-clockwise, tighten up the holder after confirmed the flute is parallel with the notch. If it's not parallel, please repeat the alignment steps. The benchmark notch.

4. Primary edge re-sharpening



1. Switch on machine.
2. Point ER holder at the notch of primary edge re-sharpening port NO.1.
3. Insert the holder into the port NO.1 with a slight push motion for grinding.
4. Change to another flute, repeat the above steps until the sharpening for all flutes' edges is complete.

5. Relief settings



1. If the relief needs to be adjusted, please use provided 4mm hex. wrench to loosen the screws in the sharpener NO.1.
2. Rotate clockwise(+) to increase, rotate counterclockwise(-) to decrease. Tighten after relief setting.

6. Secondary clearance angle sharpening-1(for 4 flutes)



1. Pointing ER holder at screw secondary clearance angle sharpening port NO.2, insert it into the port with a slight push motion to sharpen until grinding noise disappears.
2. Change to another flute, repeat the above steps until the sharpening for all flutes' edges is complete.

7. Secondary clearance angle sharpening-2(for 2 and 3 flutes)



1. If you need to sharpen the secondary clearance angle completely, loosen the screws in the secondary clearance angle port, and then rotate left and right repeatedly for clearance.
Attn: The rotation ranges for 2 flutes and 3 flutes are different. For 2 flutes, rotate the holder left and right in whole rotation; for 3 flutes, on the sharpening port NO.2, rotate the benchmark notch side only.
2. The grinding should start from the flute pointed at the benchmark notch.

8. End gash sharpening



1. Pointing ER holder at upper screw of end gash sharpening port NO.3, insert it into the port with a slight push motion. For precise and average grinding, hold tight the upper part of the ER holder with one hand and move the lower port at both sides with another hand to sharpen until grinding noise disappears.
2. Take out the holder with end mill and change to another flute, repeat the above steps until the sharpening for all flutes' end gashes is complete.
3. Take out the end mill from the the holder and inspect it.

Replacing The Wheel

1. Removing the wheel cover



1. Unplug the machine.
2. Loosen the three screws in the wheel cover counterclockwise with 4mm Allen key.

2. Cleaning the grinding dust



1. Make sure the temperature of the wheel goes down to normal temperature.
2. Open the upper cover, clean the grinding dust with pressurized air and wipe outside with dry cloth.

3. Removing the washer



1. Hold the wheel with left hand and loosen the screw counterclockwise with 4mm Allen key with right hand.
2. Take out the black washer.
3. Take out the wheel from the motor hub slightly.

4. Replacing the wheel



1. Take a new proper wheel.
2. To re-install the wheel, reverse steps taken to remove wheel.
※ The motor hub is very precise, it will be damaged by excessive force and affect the position of wheel accordingly.

Caution:

1. Determine the material of end mill before grinding. Please use SDC diamond wheel for carbide end mill; please use CBN diamond wheel for HSS end mill.
2. Determine the flute of the end mill and use the proper collet holder; GH-413 / 1225 is suitable for 2, 3, and 4 flute end mill.
3. Aligning end mill is the most important among the steps, make sure to complete this step before grinding.
4. This machine is guaranteed for one year under normal operation (expendable parts and wheels are exceptions), please inform the serial no. when the machine needs to be repaired.
5. For end mill 4~5mm, be sure to use a very slight push motion while grinding the primary edge due the outer diameter of wheel is smaller.
6. The motor cannot run continuously over 1 hour.



Precision Machinery

69280-01 GM213 Fast Drill Re-sharpening



Features:

- ▶ Double bearings grinding unit (reduce wear).
- ▶ Drill tightening design with bearing device.
- ▶ Adjustable trimming angle.

Standard Accessories:

1. ER Collet 2.5mm~13mm (12pcs)
2. CBN Dimand Wheel #200 x 1pc (High speed drill)
3. 4mm, 5mm Hexagon(Hex.) Wrench x 1pc each.

Optional Accessories:

1. SDC #400 Diamond Wheel (Carbide Drill)
2. SBN #400 Diamond Wheel (<4mm, High Speed drill)
3. ERCollets, 3.5~12.5mm(10pcs)

Refer to P.J34 for instruction manual

Specify voltage when ordering.

Order No.	Model	Range	Point Angle	Power	Motor	Speed	Package	N.W.
69280-01-110-1	GM213	2mm~13mm	85°~140°	110V,50/60Hz,1PH	90W	6000rpm	305x172x180mm	10kgs
69280-01-220-1				220V,50/60Hz,1PH				

69280-02 GM1226 Fast Drill Re-sharpening



Features:

- ▶ Double bearings grinding unit (reduce wear).
- ▶ Drill tightening design with bearing device.
- ▶ Adjustable trimming angle.

Standard Accessories:

1. ER Collet 12mm~26mm (15pcs)
2. CBN Dimand Wheel #150 x 1pc (High speed drill)
3. 4mm, 6mm Hexagon(Hex.) Wrench x 1pc each.

Optional Accessories:

1. SDC #200 Diamond Wheel (Carbide Drill)
2. ER Collets, 8~11mm, 27~30mm(8pcs)

Refer to P.J34 for instruction manual

Specify voltage when ordering.

Order No.	Model	Range	Point Angle	Power	Motor	Speed	Package	N.W.
69280-02-110-1	GM1226	12mm~26mm	85°~140°	110V,50/60Hz,1PH	450W	4000rpm	476x260x235mm	29kgs
69280-02-220-1				220V,50/60Hz,1PH				



Features:

- ▶ Double bearings grinding unit (reduce wear).
- ▶ Drill tightening design with bearing device.
- ▶ Adjustable trimming angle.

Standard Accessories:

1. ER Collet 3mm~26mm (18pcs)
2. CBN Dimand Wheel #150 x 1pcs
(High speed drill)

Optional Accessories:

1. SDC #200 Diamond Wheel (Carbide Drill)

Refer to P.J34 for instruction manual

Specify voltage when ordering.

Order No.	Model	Range	Point Angle	Power	Motor	Speed	Package	N.W.
69290-110-1	GM320	3mm~20mm	85°~140°	110V,50/60Hz,1PH	450W	4300rpm	480x260x240mm	21kgs
69290-220-1				220V,50/60Hz,1PH				



Precision Machinery

GM213 / 1226 Procedures for grinding wheel replacement

GM213



GM1226



Procedures for changing the grinding wheel

1. Loosen the side knob (B1) and open the side cover (B2).
2. Use a 4mm hexagon wrench to loosen the screw (B3), unscrew it counter clockwise.
3. Replace with a new diamond grinding wheel and tighten the screw after the wheel is installed.
4. Be sure to close the side cover (B2) properly and to fasten the side knob (B1).

Attention!

Please **DO NOT** switch on machine **BEFORE**

- (1) The diamond wheel screw (B3) is tightly screwed.
 - (2) The side cover (B2) is properly closed.
 - (3) The right knob (B1) is fully fastened.
1. In case of any hazard occurring, please make sure that the above measures are followed strictly.
 2. The machine has an automatic Power-off device to ensure operator's safety. Power supply will be cut-off immediately when the cover is opened.

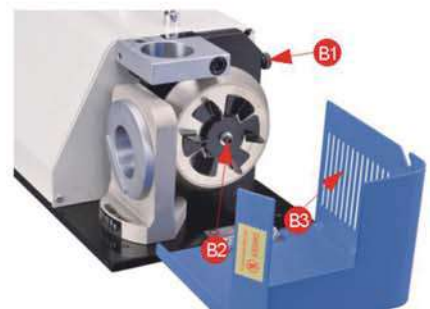

Operations

1. Procedures for changing the grinding wheel

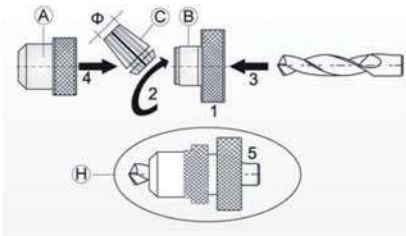

1. Choose the collet accordingly to the drill diameter.
2. Slot the chosen collet holder (B) at an appropriate angle.
3. Insert the drill into the connected collet and collet holder set, leave a 35mm extension of the drills original body length, but do not tighten the drill too tight.
4. Connect the collet nut (A) to the unit of collet (C) which is locked to the collet holder (B), and tighten the set, yet make sure the drill is not firmly tightened, but still able to be turned.
5. Complete the above steps, so the collet chuck set (H) is ready for drilling.

2. Setting the drill length and position its movement for drilling

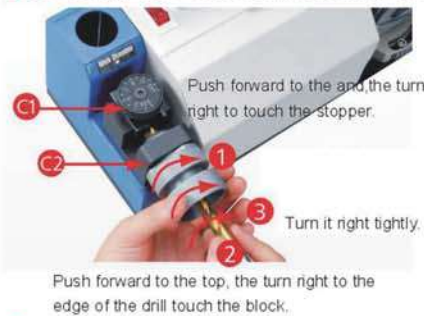

1. Reset the scale ring (C1): Turn the ring all the way clockwise, and then turn it anti-clockwise to the required drilling size indicated on C1.
2. Insert collet chuck set (see 1) into presrt length bracket (C2) and make sure the pin locked to the slot.
3. Turn the collet chuck set clockwise until it touches against the pin (see 2), and turn the drill clockwise till it touches against the drill cutting edge.
4. Screw the ER collet holder (see 3) clockwise to tighten the drill.
5. Take out the collet chuck set to check if the drill cutting edge is parallel to the slot of Erclamping nut. If it's not parallel, please repeat the above steps.
6. Attention: For used drill, with less than 1/4 (three quarters) of its original length left, it is advisable to adjust the 1~2mm scale up on the Scale Ring.

3. Point angle grinding for drill



1. Insert the collet chuck set into Point Angle Bracket (see 1), and set the slot into the pin.
2. Make the collet chuck set touching the wheel lightly (see 2), turn clockwise and reverse until the grinding sound disappears.
3. Take out the collet chuck set, rotate it 180° degree, and repeat step 1 and 2 to finish the grinding for the two drill chisel edge angles.

4. Center point trimming grinding for drill



1. Insert collet chuck set (see 1) into the grinding unit and insert the slot into the pin (see 2).
2. Place collet chuck set (see 1) upright and insert it into the top bracket to lightly touch the wheel. Turn it clockwise and reverse until grinding noise disappears.
3. Take out collet chuck set, rotate it 180° degree and repeat step 1 and 2 to finish up the grinding.

5. Adjustment for trimming angle



1. To obtain a larger trimming angle - turn the (F1) Screw anti-clockwise (+), (-).



69300/02 MG **3 Slant Fast Drill Re-sharpening**



69300

特點:

- ▶ 雙軸承研磨座。
- ▶ 鑽頭鎖緊設計裝置有軸承。
- ▶ 可調靜點座。



69302



Standard accessories

Power wires	1SET
Fuse	1SET
Hex.wrench	4mm/5mm
Diamond wheel	CBN200# (Order No.: 69300-A)
Diamond wheel	CBN400# (Order No.: 69300-B)
ER20 collet chuck	1SET
ER20 collet	2~13mm(12pcs)
ER40 collet	12~26mm(15pcs)(MG1226)

Opandard accessories

ER20 collet chuck	3.5,4.5,5.5,6.5,7.5,8.5,9.5,10.5,11.5,12.5mm
ER40 collet	27,28,29,30mm

※ 操作使用程序請參閱P.J36頁

Order No.	Model	Capacity	Axial angles	Power	Motor	Speed	LxWxH	N.W.
69300-110-1	MG213	3mm~13mm	140°	110V,50/60Hz,1HP	200W	5500rpm	305x172x180mm	10kgs
69300-220-1				220V,50/60Hz,1HP				
69302-110-1	MG1226	12mm~26mm	140°	110V,50/60Hz,1HP	450W	4000rpm	470x260x235mm	28kgs
69302-220-1				220V,50/60Hz,1HP				

Operations

1. Preparation before drill grinding

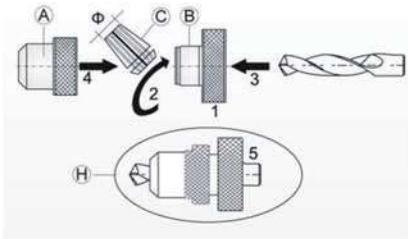

1. Check drill diameter, then select proper size of collet (C).
2. Fit the selected collet into the collet holder (B) with a proper angle.
3. Insert the drill into the collet, and have it protrude about 35mm. At this time do not tighten the drill securely.
4. Fit the nut (A) into the collet (C), then tighten it to the nut (B) Slightly tighten it and allow the drill to be turned by hand.
5. Complete above steps to finish preparation before grinding a drill.

2. Setting drill length and angle



1. Turn the graduated collar (C1) clockwise to the end, then turn it counter clockwise to the size of drill to be ground.
2. Insert the ER collet chuck (H) into the length setting unit (C2), and make sure the pin is locked to the slot.
3. Turn the collet chuck (H) clockwise until it touches the pin. Turn the drill clockwise until it touches the drill cutting edge.
4. Turn the ER nut (B) clockwise to tighten the drill.
5. Take out the collet chuck (H). Check to see if the drill cutting edge is parallel to the slot of ER collet chuck. If not, make setting again.
6. NOTE: If a drill is used to less than 3/4 of its original length, the graduated collar should be turned over 1-2 graduation.

3. Grinding and primary adjusting dead point of drill



1. Align the straight pin at the front end of the ER collet chuck (H) with the slot then insert it.
2. Have the drill in the ER collet chuck slightly touch the grinding wheel. Perform slow feed for pressing it to the bottom. Until grinding sound disappears.
3. Take out the collet chuck (H). Rotate it 180°. Repeat step 1 and 2 for repetitive grinding to finish the dead point grinding.
4. To increase dead point, turn the screw (F1) left clockwise to adjustment (+).
5. To reduce dead point, turn the screw (F1) left clockwise to adjustment (-).

4. Grinding and primary adjusting secondary clearance angle of drill

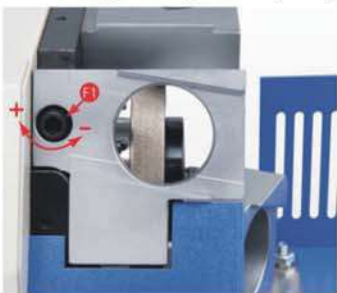

1. Align the straight pin at the front end of the ER collet chuck (H) with the slot then insert it in secondary clearance angle set.
2. Have the drill in the ER collet chuck slightly touch the grinding wheel. Perform slow feed for pressing it to the bottom. Until grinding sound disappears.
3. Take out the collet chuck (H). Rotate it 180°. Repeat step 1 and 2 for repetitive grinding to finish the Secondary clearance angle grinding.
4. To increase dead point, turn the screw (F1) left clockwise to adjustment (+).
5. To reduce dead point, turn the screw (F1) left clockwise to adjustment (+).

5. Grinding end esge



1. Align the straight pin at the front end of the ER collet chuck (H) with the slot on the end edge grinding unit.
2. Have the drill in the ER collet chuck slightly touch the grinding wheel. Perform slow feed for pressing it to the bottom. Until grinding sound disappears.
3. Take out the collet chuck (H). Rotate it 180°. Repeat step 1 and 2 for repetitive grinding to finish the clearance angle grinding to finish the end edge grinding.

Precision Machinery

69410

GAQ

Air Tapping Machine



Features:

- ▶ High tapping efficiency and no easy to break tap.
- ▶ Adopting pneumatic and suitable for Steel, Iron, Copper, Plastic materials tapping.
- ▶ Universal arm design for lateral, vertical, any angle tapping.
- ▶ Work table is not included, optional accessory.

Standard Accessories:

1. Air Tapping Spindle
2. Extended Arm
3. Fixed Base
4. 3-points Combination
5. Safety Torque Tapping Collets x 6 pcs
6. Swing Arm

Unit:mm

Order No.	Model	Capability	Spindle Speed R.P.M.	Work Range	N.W.
69410-01	GAQ08	M2-M8	700	Rmax 950mm Rmin 100mm	16kg
69410-02	GAQ12	M3-M12	400		16kg
69410-03	GAQ16	M3-M16	300		24kg

69420

GAQ

Air Tapping Machine



Features:

- ▶ High tapping efficiency and no easy to break tap.
- ▶ Adopting pneumatic and suitable for Steel, Iron, Copper, Plastic materials tapping.
- ▶ Universal arm design for lateral, vertical, any angle tapping.
- ▶ Work table is not included, optional accessory.

Standard Accessories:

1. Air Tapping Spindle
2. Extended Arm
3. Fixed Base
4. 3-points Combination
5. Safety Torque Tapping Collets x 6 pcs
6. Swing Arm

Unit:mm

Order No.	Model	Capability	Spindle Speed R.P.M.	Work Range	N.W.
69420-01	GAQ20	M3-M20	150/400	Rmax 1000mm Rmin 100mm	25kg
69420-02	GAQ22	M3-M22	120/300		25kg
69420-03	GAQ24	M3-M24	100/300		25kg
69420-04	GAQ27	M3-M27	70/220		25kg

69430 **GAT08/12** **Air Tapping Machine**



Features:

- ▶ High tapping efficiency and no easy to break tap.
- ▶ Adopting pneumatic and suitable for Steel, Iron, Copper, Plastic materials tapping.
- ▶ Universal arm design for lateral, vertical, any angle tapping.
- ▶ Work table is not included, optional accessory.

Standard Accessories:

1. Air Tapping Spindle
2. Extended Arm
3. Fixed Base
4. 3-points Combination
5. Safety Torque Tapping Collets x 6 pcs
6. Swing Arm, extended 500mm.

Unit:mm

Order No.	Model	Capability	Spindle Speed R.P.M.	Work Range	N.W.
69430-01	GAT08	M2-M8	700	Rmax 1900mm	23kg
69430-02	GAT12	M3-M12	400	Rmin 100mm	23kg

69440 **GAT16** **Air Tapping Machine**

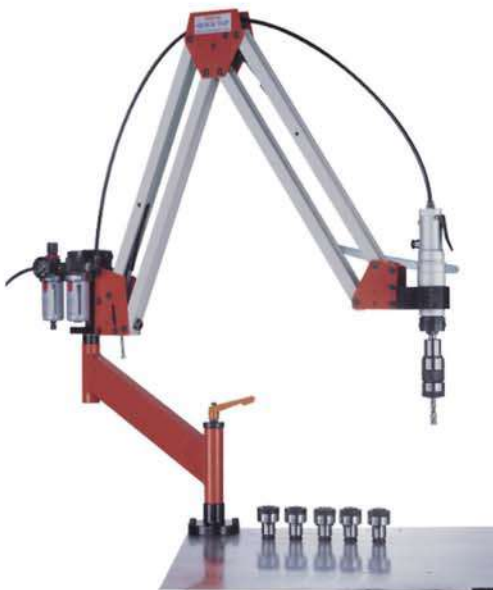

Features:

- ▶ High tapping efficiency and no easy to break tap.
- ▶ Adopting pneumatic and suitable for Steel, Iron, Copper, Plastic materials tapping.
- ▶ Universal arm design for lateral, vertical, any angle tapping.
- ▶ Work table is not included, optional accessory.

Standard Accessories:

1. Air Tapping Spindle
2. Extended Arm
3. Fixed Base
4. 3-points Combination
5. Safety Torque Tapping Collets x 6 pcs
6. Swing Arm, extended 500mm.

Unit:mm

Order No.	Model	Capability	Spindle Speed R.P.M.	Work Range	N.W.
69440	GAT16	M3-M16	300	Rmax 1900mm Rmin 200mm	27kg

69450 GHM Hydraulic Tapping Machine



GHM22



GHM32/42/50



GHM60

Features:

- ▶ High tapping efficiency and no easy to break tap.
- ▶ Adopting pneumatic and suitable for Steel, Iron, Copper, Plastic materials tapping.
- ▶ Universal arm design for lateral, vertical, any angle tapping.
- ▶ Work table is not included, optional accessory.

Standard Accessories:

1. Hydraulic Tapping Spindle
2. Extended Arm
3. Fixed Base
4. 3-points Combination
5. Work Cabinet
6. Electric Motor, Hydraulic Pump, Hydraulic Box.
7. Electric Controlled Device.

Specify voltage when ordering.

Order No.	Model	Capability	Spindle Speed R.P.M.	Work Range	Voltage	Power	Hydraulic	N.W.
69450-01	GHM22	M3-M22	0~400	Max. Radius1600mm Min. Radius200mm	220/380V, 50/60Hz 3PH	3HP	100kg/cm ²	300kg
69450-02	GHM32	M4-M32	0~550/0~105			3HP	100kg/cm ²	300kg
69450-03	GHM42	M4-M42	0~400/0~75			3HP	100kg/cm ²	300kg
69450-04	GHM50	M8-M50	0~360/0~60			5HP	140kg/cm ²	300kg
69450-05	GHM60	M8-M60	0~360/0~60			10HP	140kg/cm ²	450kg

Unit:mm



Features:

- ▶ 90° or any angle tapping device, mostly suitable for GAQ/GAT series.
- ▶ Automatic tap lubricator system.
- ▶ Suitable for tapping, chamfering, boring, lock screws.
- ▶ Universal arm design for lateral, vertical, any angle tapping.

Order No.	Model	N.W.
69460-01	GAQ/GAT08-90°	2kg
69460-02	GAQ/GAT12-90°	2kg
69460-03	GAQ/GAT16-90°	2kg
69460-04	GAQ/GAT20-90°	2kg
69460-05	GAQ/GAT22-90°	2kg
69460-06	GAQ/GAT24-90°	2kg
69460-07	GAQ/GAT30-90°	2kg

Air Grinder(Japan Series)

70000

TLL-07

Reciprocating Ultrasonic Air Grinder

Stroke: 0.7mm
Free speed at 90psi: RPM22, 000
Air consumption: 46nl/min
Dimensions: \varnothing 28x196L
Weight: 166g



70001

TLL-03

Reciprocating Ultrasonic Air Grinder

Stroke: 0.3mm
Free speed at 90psi: RPM55, 000
Air consumption: 125nl/min
Dimensions: \varnothing 28x196L
Weight: 166g



70002

TLL-1.2

Reciprocating Ultrasonic Air Grinder

Stroke: 1.2mm
Free speed at 90psi: RPM15, 000
Air consumption: 45nl/min
Dimensions: \varnothing 28x196L
Weight: 166g



70003

TLL-0.15

Reciprocating Ultrasonic Air Grinder

Stroke: 1.5mm
Free speed at 90psi: RPM55, 000
Air consumption: 125nl/min
Dimensions: \varnothing 28x196L
Weight: 166g



70004

FX-A3.0

High Speed Straight Air Grinder

Free speed at 90psi: RPM65, 000
Air consumption: 120nl/min
Dimensions: \varnothing 22.5x150L
Weight: 78g



70005**MSG-3BSN****High Speed Straight Air Grinder**

Free speed at 90psi: RPM65, 000
Air consumption: 120nl/min
Dimensions: \varnothing 17x143L
Weight: 130g

**70006****MAG-123N****Surface Air Grinder (120°)**

Free speed at 90psi: RPM23, 500
Air consumption: 120nl/min
Dimensions: \varnothing 17x50x123L
Weight: 175g

**70007****MAG-093N****Surface Air Grinder (90°)**

Free speed at 90psi: RPM23, 500
Air consumption: 120nl/min
Dimensions: \varnothing 17x44x118L
Weight: 160g

**70008****MAG-121N****Inner Hole Air Grinder (120°)**

Free speed at 90psi: RPM52, 500
Air consumption: 120nl/min
Dimensions: \varnothing 17x78x107L
Weight: 140g

**70009****MAG-122N****Inner Hole Air Grinder (90°)**

Free speed at 90psi: RPM35, 000
Air consumption: 120nl/min
Dimensions: \varnothing 17x55x104L
Weight: 140g



Air Grinder

70010

AIR-917/913

Ultrahigh Speed Grinding Machine

Order no.: AIR-917 or AIR-913
Stroke: 0.7或0.3(mm)
Free speed at 90psi: RPM35,000/40,000
Collet chuck: $\varnothing 1, \varnothing 3$ mm
Dimensions: $\varnothing 29 \times 228$ L
Weight: 170g
Feature: Lightweight, long-work capable.



70011

AIR-947/943

Turbine Long Time Operation

Order no.: AIR-947 or AIR-943
Stroke: 0.7 or 0.3mm
Free speed at 90psi: RPM35,000/40,000
Collet chuck: $\varnothing 1, \varnothing 3$ mm
Dimensions: $\varnothing 26 \times 217$ L
Weight: 181g
Feature: Lightweight, long-work capable., NSK bearings applied



70012

AIR-951

High Speed Air Grinder

Free speed at 90psi: RPM70,000
Collet chuck: $\varnothing 3, \varnothing 1/8, \varnothing 2.4$ mm
Dimensions: $\varnothing 18 \times 150$ L
Weight: 82g
Feature: Lightweight, long-work capable., NSK bearings applied



70013

AIR-953

High Speed Air Grinder

Free speed at 90psi: RPM80,000 4叶片
Collet chuck: $\varnothing 3$ mm
Dimensions: $\varnothing 18 \times 162$ L
Weight: 110g
使用方法: 馬達與研磨頭各分美國杜邦葉片



70014

AIR-954

High Speed Air Grinder

Free speed at 90psi: RPM80,000
Collet chuck: $\varnothing 3$ mm
Dimensions: $\varnothing 17 \times 155$ L
Weight: 125g
使用方法: 美國杜邦4葉片馬達、研磨分開



70015 AIR-952 High Speed Air Grinder

Free speed at 90 psi: RPM70,000
 Collet chuck: $\varnothing 3, \varnothing 1/8, \varnothing 2.4\text{mm}$
 Dimensions: $\varnothing 18 \times 135\text{L}$
 Weight: 118g
 Feature: Lightweight, long-work capable., NSK bearings applied



70016 AIR-965 45° Angle Air Grinding

Free speed at 90 psi: RPM35,000
 Collet chuck: $\varnothing 30\text{mm}$
 Dimensions: $\varnothing 30 \times 168\text{L}$
 Weight: 218g



70017 AIR-967 Surface Air Grinder (90°)

Free speed at 90 psi: RPM35,000
 Collet chuck: $\varnothing 30\text{mm}$
 Dimensions: $\varnothing 30 \times 158\text{L}$
 Weight: 200g



70018 AIR-A965 Inner Hole Air Grinder (45°)

Free speed at 90 psi: RPM35,000
 Collet chuck: $\varnothing 30\text{mm}$
 Dimensions: $\varnothing 30 \times 168\text{L}$
 Weight: 218g



70019 AIR-A967 Inner Hole Air Grinder (90°)

Free speed at 90 psi: RPM35,000
 Collet chuck: $\varnothing 3, \varnothing 30\text{mm}$
 Dimensions: $\varnothing 30 \times 158\text{L}$
 Weight: 200g



Air Grinder

70020

A971

0.3 HP Air Grinder

Free speed at 90psi: RPM28,000
Collet chuck: $\varnothing 3, \varnothing 6$ mm
Dimensions: $\varnothing 32 \times 287$ L
Weight: 591g



70021

A972

Swing Surface Air Grinder

Free speed at 90psi: RPM28,000
Collet chuck: Steel plate x 2
Dimensions: $\varnothing 32 \times 205$ L
Weight: 525g



70022

A973

Grinding Wheel Grinder

Free speed at 90psi: RPM28,000
Collet chuck: $\varnothing 3, \varnothing 6$ mm
Dimensions: $\varnothing 32 \times 165$ L
Weight: 372g



70023

A974

Swing Air Lapper

Free speed at 90psi: RPM28,000
Collet chuck: $\varnothing 6$ mm
Dimensions: $\varnothing 32 \times 180$ L
Weight: 575g



Demostration of Air Die Grinders



Please refer to GinTech Mold Components, for more info log onto www.gin-chan.com



Diamond Files



Diamond Burs



Solid Carbide



Grinding Pins



Gin Tech Precision Co., Ltd. Copyrighted; All Rights Reserved

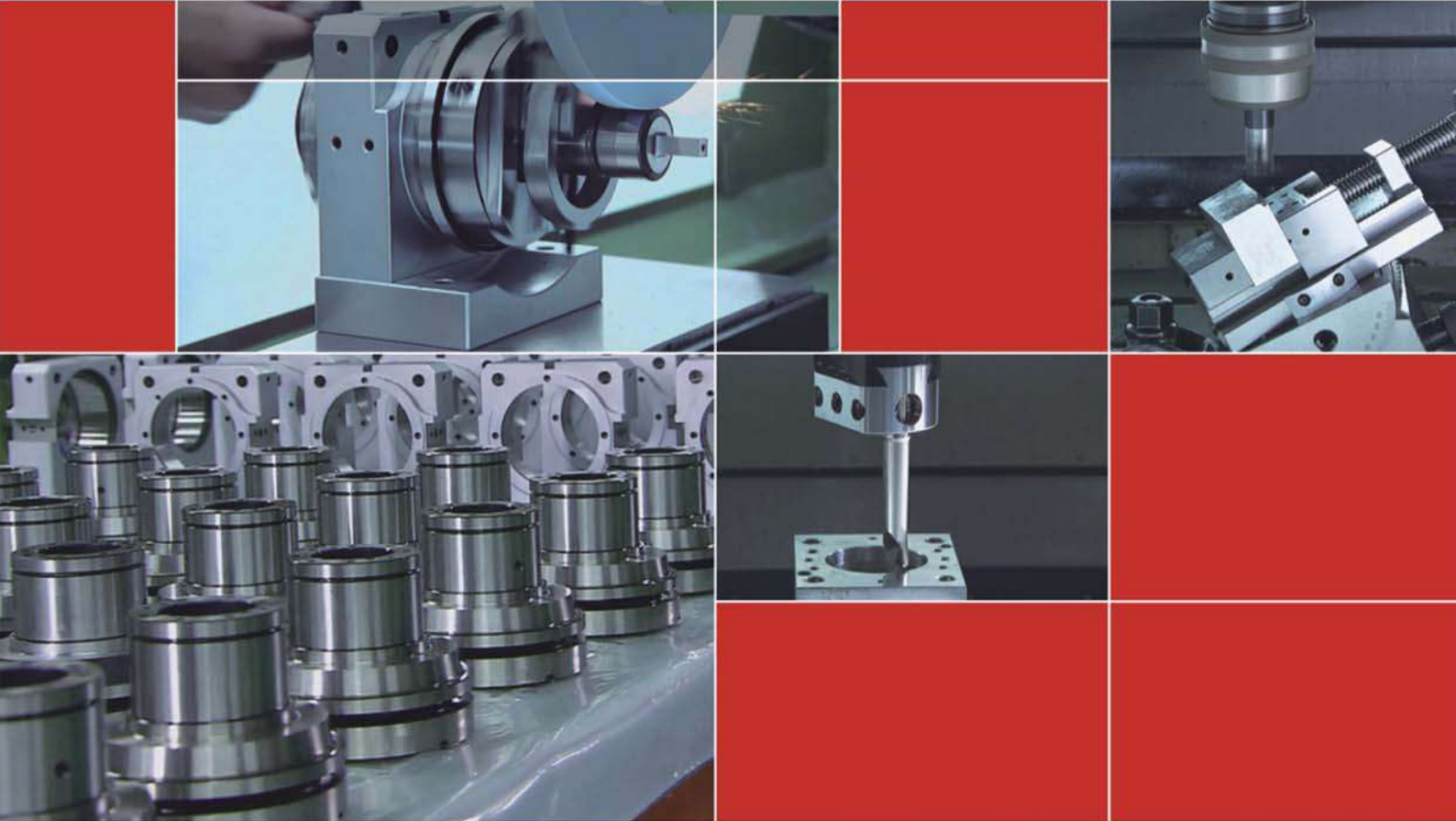

Gin Chan reserves right to amend the product content without prior notice

精展精密科技股份有限公司 (總公司)
GIN TECH PRECISION CO.,LTD.

台灣238新北市樹林區保安街一段341巷7號
Address: No 7, Lane 341, Sec. 1, Bau An Street, Shu lin Dist.,
23841, New Taipei City, Taiwan
TEL: 886-2-2681-8596 (Rep.)  Sales@ginchan.com.tw
FAX: 886-2-2681-8516  www.ginchan.com.tw

大陸總經銷
東莞美商精展機械五金有限公司
東莞市精展機械五金有限公司
GIN CHAN MACHINERY & HARDWARE CO.,LTD.(DONGGUAN)

廣東省東莞市大朗鎮石廈村金沙崗二路27號
Tel : 86-769-8318-5858 (Rep.)
Fax: 86-769-8318-5838/8313-5003
 www.ginchan.com.cn  sales@ginchan.com.cn



Scan Now!

