

# Lathe Accessories

---



**H01-H48**

# INDEX

H01~06

## Scroll Chuck for Lathe



66800 H01



66810 H01



66820 H02



66830 H02



66840 H03



66850 H03



66860 H04



66870 H04



66880 H05



66890 H06

H07~12

## Steel Body Scroll Chuck for Lathe



66892 H07



66894 H08



66896 H09



66898 H09



66900 H10



66905 H10



66910 H11



66915 H12

**H13~26**
**Rolling Live Center for Lathe**

66920 H13

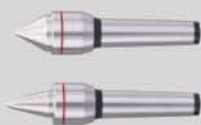

66922 H14



66923 H14



66925 H15



66927 H16



66928 H16



66930 H17



66931 H17



66933 H18



66935 H19



66936 H19



66938 H20



66940 H21



66942 H22



66944 H23



66945 H24

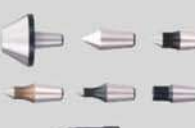

66946~48 H25



66949 H26

**H27~32**
**Dead Center for Lathe**

66950 H27



66951 H27



66952 H28



66953 H28

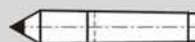

66954 H29



66955 H29



66956 H30



66957 H31



66958 H31

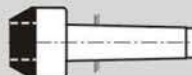

66959 H32

# Lathe Machine Accessories

**66800**

sc

**3-Jaw Scroll Chuck**



## Features:

- ▶ Suitable for clamping small round workpiece.
- ▶ Auto centering.
- ▶ Internal Jaw & External Jaw are interchangeable.

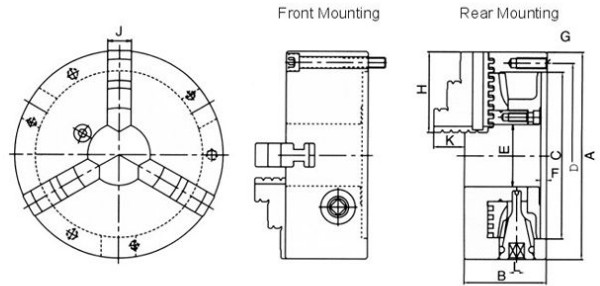

Unit:mm

Order No.	Model	A	B	C	D	E	F	G	H	J	K	L	Max.Speed (r.p.m.)	Max.Gripping Diameter		N.W.
														O.D.Clamping	I.D.Clamping	
66800-03	SC03	85	45	60	73	16	3.5	3-M8x1P	35	11	15	7	2500	∅2-70	∅24-64	1.5kg
66800-04	SC04	112	58	80	95	24	4.5	3-M8x1.25P	42	14	17	8	2500	∅3-90	∅32-84	3.3kg
66800-05	SC05	132	60	100	115	32	4.5	3-M8x1.25P	50	16	20	8	2500	∅3-110	∅35-100	4.6kg
66800-06	SC06	167	66	130	147	45	5	3-M10x1.5P	65	19	23	10	2000	∅4-160	∅48-150	7.9kg
66800-07	SC07	193	76	155	172	58	5	3-M10x1.5P	75	22	28	11	2000	∅4-180	∅56-170	12.0kg
66800-08	SC08	203	76	160	176	58	5	3-M10x1.5P	75	22	28	11	2000	∅4-180	∅56-170	13.3kg
66800-09	SC09	233	84	190	210	70	5.5	3-M12x1.75P	85	24	34.5	12	2000	∅5-220	∅62-210	19.3kg
66800-10	SC10	273	86	230	250	89	5.5	3-M12x1.75P	98	28	39	12	1800	∅6-260	∅70-250	26.2kg
66800-12	SC12	310	96	260	285	105	7	3-M12x1.75P	110	30	45	14	1800	∅10-300	∅86-290	37.6kg
66800-16	SC16	405	122	345	375	160	8	6-M14x2P	146	40	56	15	1500	∅14-400	∅100-380	80.7kg

Specify: "Front mounting" or "Rear mounting" when ordering.

**66810**

PS

**4-Jaw Scroll Chuck**



## Features:

- ▶ Suitable for clamping small round workpiece.
- ▶ Auto centering.
- ▶ Internal Jaw & External Jaw are interchangeable.

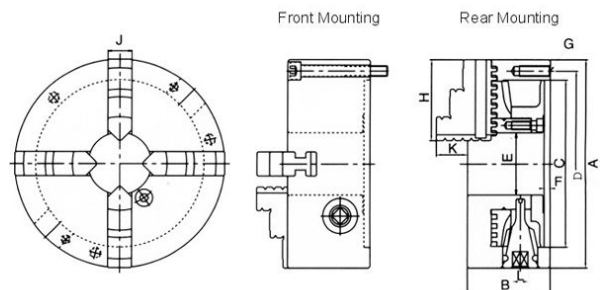

Unit:mm

Order No.	Model	A	B	C	D	E	F	G	H	J	K	L	Max.Speed (r.p.m.)	Max.Gripping Diameter		N.W.
														O.D.Clamping	I.D.Clamping	
66810-07	PS07	193	76	155	172	58	5	3-M10x1.5P	75	22	28	11	2000	∅4-180	∅56-170	12.1kg
66810-09	PS09	233	84	190	210	70	5.5	3-M12x1.75P	85	24	34.5	12	2000	∅5-220	∅62-210	19.4kg
66810-12	PS12	310	96	260	285	105	7	3-M12x1.75P	110	30	45	14	1800	∅10-300	∅86-290	38.1kg
66810-16	PS16	405	122	345	375	160	8	6-M14x2P	146	40	56	15	1500	∅14-400	∅100-380	82.4kg

Specify: "Front mounting" or "Rear mounting" when ordering.

**66820 AS Conical 6-Jaw Scroll Chuck**



**Features:**

- ▶ Suitable for clamping all kinds of cutting tools.
- ▶ Suitable for clamping all kinds of thin workpieces.

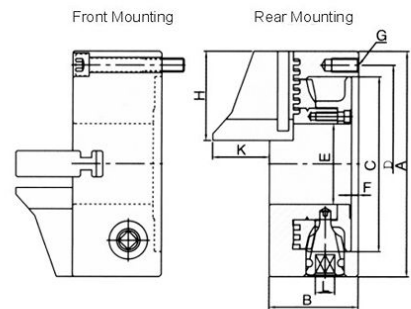
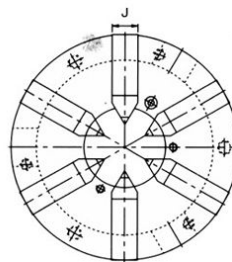

Unit:mm

Order No.	Model	A	B	C	D	E	F	G	H	J	K	L	Max.Speed (r.p.m.)	Max.Gripping Diameter	N.W.
														O.D.Clamping	
66820-04	AS04	112	58	80	95	32	4.5	3-M8x1.25P	45	14	46	8	1200	∅2-32	3.8kg
66820-06	AS06	167	65	130	147	60	5	3-M10x1.5P	66	19	43	10	1200	∅3-60	8.2kg

Specify: "Front mounting" or "Rear mounting" when ordering.

**66830 AE Conical 8-Jaw Scroll Chuck**



**Features:**

- ▶ Suitable for clamping all kinds of cutting tools.
- ▶ Suitable for clamping all kinds of thin workpieces.

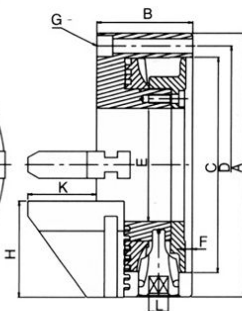

Unit:mm

Order No.	Model	A	B	C	D	E	F	G	H	J	K	L	Max.Speed (r.p.m.)	Max.Gripping Diameter	N.W.
														O.D.Clamping	
66830-09	AE09	233	84	190	210	100	5.5	4-M12x1.75P	85	24	60	12	1000	∅7-100	21kg

# Lathe Machine Accessories

## 66840 SK Powerful 3-Jaw Scroll Chuck

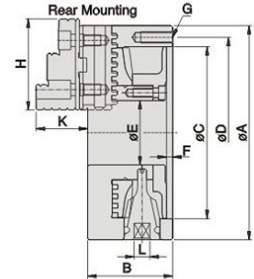
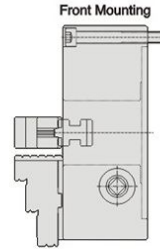
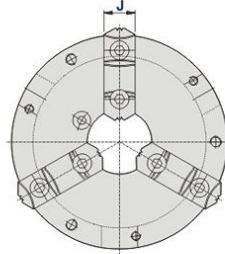

### Features:

- ▶ Suitable for heavy duty cutting, jaws can be used as internal or external jaws.
- ▶ Auto centering.
- ▶ Soft jaws are available for better run-out accuracy.

Unit:mm

Order No.	Model	A	B	C	D	E	F	G	H	J	K	L	Max.Speed (r.p.m.)	Max.Gripping Diameter		N.W.
														O.D.Clamping	I.D.Clamping	
66840-04	SK04	112	58	80	95	24	4.5	3-M8x1.25P	47	19	31.5	8	2500	Ø3-100	Ø35-93	
66840-05	SK05	132	60	100	115	32	4.5	3-M8x1.25P	57	24	36	8	2500	Ø3-123	Ø43-122	
66840-06	SK06	167	66	130	147	45	5	3-M10x1.5P	68	26	39	10	2000	Ø8-160	Ø55-150	8.6kg
66840-07	SK07	193	76	155	172	58	5	3-M10x1.5P	82	28	43	11	2000	Ø8-180	Ø62-170	12.8kg
66840-08	SK08	203	76	160	176	58	5	3-M10x1.5P	82	28	43	11	2000	Ø8-180	Ø62-170	14.1kg
66840-09	SK09	233	84	190	210	70	5.5	3-M12x1.75P	93	32	50	12	2000	Ø11-220	Ø70-210	20.4kg
66840-10	SK10	273	86	230	250	89	5.5	3-M12x1.75P	102	32	54.5	12	1800	Ø12-260	Ø80-250	26.7kg
66840-12	SK12	310	96	260	285	105	7	3-M12x1.75P	118	40	56	14	1800	Ø15-300	Ø90-290	39.3kg
66840-16	SK16	405	122	345	375	160	8	6-M14x2P	150	50	75	15	1500	Ø30-400	Ø110-380	82.3kg

Specify: "Front mounting" or "Rear mounting" when ordering.

## 66850 PSK Powerful 4-Jaw Scroll Chuck

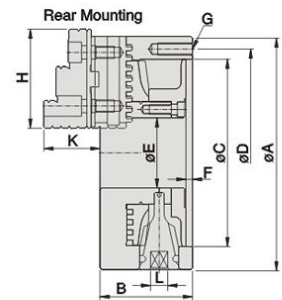
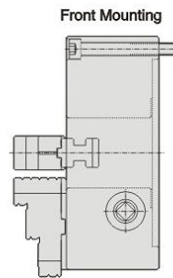
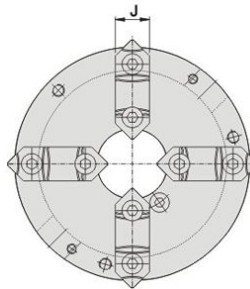

### Features:

- ▶ Suitable for heavy duty cutting, jaws can be used as internal or external jaws.
- ▶ Auto centering.
- ▶ Soft jaws are available for better run-out accuracy.

Unit:mm

Order No.	Model	A	B	C	D	E	F	G	H	J	K	L	Max.Speed (r.p.m.)	Max.Gripping Diameter		N.W.
														O.D.Clamping	I.D.Clamping	
66850-07	PSK07	193	76	155	172	58	5	3-M10x1.5P	82	28	43	11	2000	Ø8-180	Ø62-170	12.7kg
66850-09	PSK09	233	84	190	210	70	5.5	3-M12x1.75P	93	32	50	12	2000	Ø11-220	Ø70-210	20.8kg
66850-12	PSK12	310	96	260	285	105	7	3-M12x1.75P	118	40	56	14	1800	Ø15-300	Ø90-290	43kg
66850-16	PSK16	405	122	345	375	160	8.5	6-M14x2P	150	45	75.5	15	1500	Ø30-400	Ø110-380	86.7kg

Specify: "Front mounting" or "Rear mounting" when ordering.

**66860** A1 3-Jaw Chuck



**Features :**

- ▶ No need flange to install on A-5, A-6 lathe cylinder.
- ▶ Suitable for heavy duty cutting, jaws can be used as internal or external jaws.
- ▶ Auto centering.
- ▶ Soft jaws are available for better run-out accuracy.

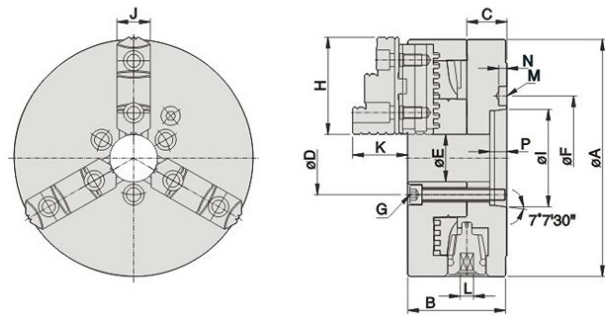

Unit:mm

Order No.	Model	A	B	C	D	E	F	G	H	I	J	K	L	P	M	N	Max.Speed (r.p.m.)	Max.Gripping Diameter		N.W.
																		O.D.Clamping	I.D.Clamping	
66860-01	A15-08"	200	83	33.5	∅61.9	40	∅104.8	3-M10x1.5P	82	82.563	28	43	11	14.29	∅16.3	7.3	2000	∅8-∅180	∅62-∅170	17.4kg
66860-02	A16-08"	200	83	33.5	∅82.6	56	∅133.4	3-M12x1.75P	82	106.375	28	43	11	15.88	∅19.3	7.5	2000	∅8-∅180	∅62-∅170	18kg
66860-03	A16-10"	255	91.5	36.5	∅82.6	56	∅133.4	3-M12x1.75P	93	106.375	32	50	12	15.88	∅19.3	7.5	1800	∅11-∅240	∅70-∅230	30.6kg

**66870** SO Power Soft Jaws

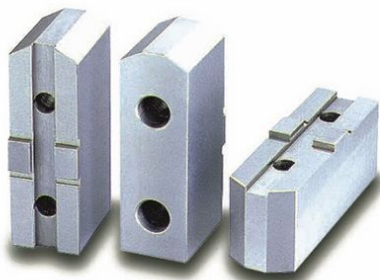

**Features :**

- ▶ Power soft jaws are available for better run-out accuracy.

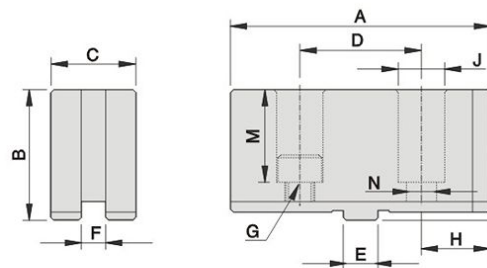

Unit:mm

Order No.	Model	A	B	C	D	E	F	G	H	J	K	L	M	N	N.W.
66870-01	SO06	73	37	26	38.1	12.68	7.94	M8x1.25P	17.45	14	3.5	3	25	9	1.3kg
66870-02	SO07	95	48	31	44.4	12.68	7.94	M10x1.5P	25.3	17	3.8	3	34	11	2.6kg
66870-03	SO09	110	48	37	54	19.03	12.7	M12x1.75P	28	19	4.2	3	34	13	3.6kg
66870-04	SO12	125	54	42	63.5	19.03	12.7	M12x1.75P	30.75	19	4.2	3	38	13	5.5kg
66870-05	SO16	160	70	50	76.2	19.03	12.7	M16x2P	41.9	25	5.5	6	48	17	10.4kg

LATHES MACHINE ACCESSORIES

# Lathe Machine Accessories

## 66880 NBK Super Thin Chuck

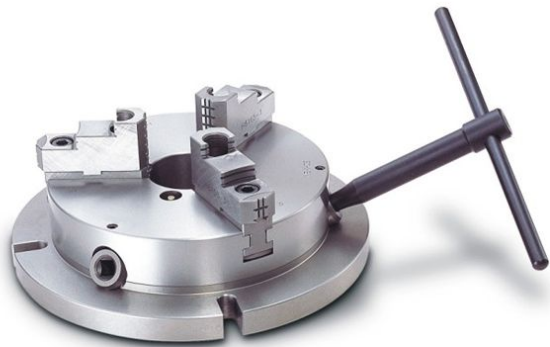

### Features :

- ▶ 30° angle between handle and chuck for better operation.
- ▶ Thin design to increase allowable processing range.
- ▶ Flange design for better & quick installation.
- ▶ Hard & Soft jaws can be used alternatively.

LATHES MACHINE ACCESSORIES

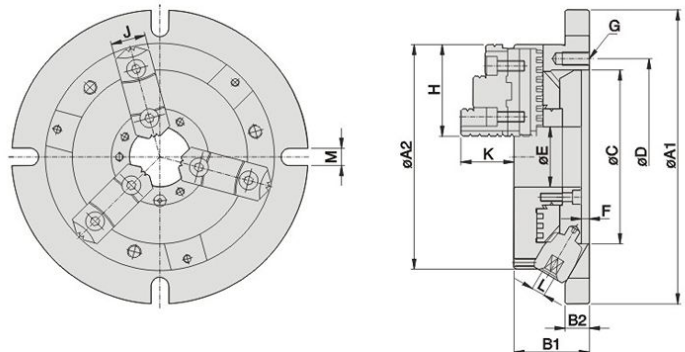

Unit:mm

Order No.	Model	A1	A2	B1	B2	C	D	E	F	G	H
66880-06	NBK06	220	170	58	18	130	147	45	6	3-M10x1.5P	68
66880-08	NBK08	270	210	65	20	155	172	60	6	3-M10x1.5P	82
66880-10	NBK10	315	255	73	20	190	210	80	6	3-M12x1.75P	93
66880-12	NBK12	370	305	80	22	250	285	105	5	3-M12x1.75P	118

Order No.	Model	J	K	L	M	Max.Gripping Diameter		N.W.
						O.D.Clamping	I.D.Clamping	
66880-06	NBK06	26	40	10	13	ø8~ø160	ø48~ø150	10.6kg
66880-08	NBK08	28	43	11	13	ø11~ø200	ø62~ø190	18.1kg
66880-10	NBK10	32	52	12	16	ø12~ø250	ø72~ø240	27.9kg
66880-12	NBK12	40	59	14	18	ø15~ø300	ø86~ø290	42.9kg



**66890** MC Super Thin Square Chuck



**Features :**

- ▶ Precision ground and make the accuracy of W, X, Y, Z among chuck are within 0.05mm.
- ▶ Soft jaw is interchangeable for machining irregular shaped workpieces instead of making & design jigs.
- ▶ Repeat accuracy within 0.02mm
- ▶ Parallel gripping accuracy can be controlled within 0.05mm after aligning sides of chucks.
- ▶ Hard Jaws are standard accessory.

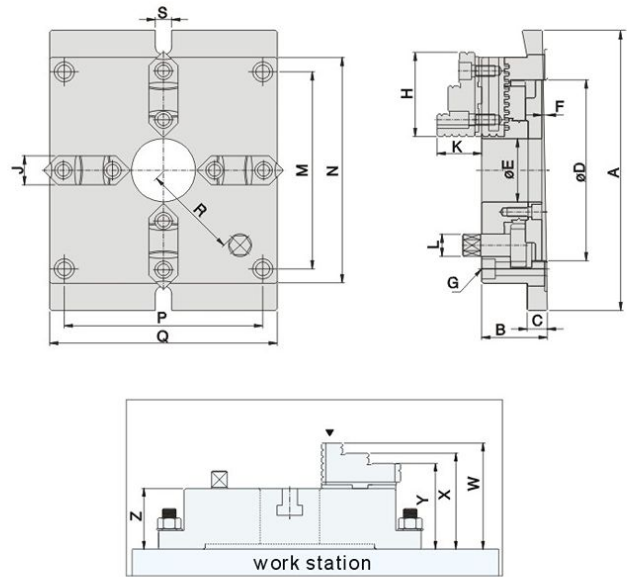

LATHES MACHINE ACCESSORIES

Unit:mm

Order No.	Model	A	B	C	D	E	F	G	H	J	K	L	M
66890-06	MC06	215	57	18	130	40	5.5	4-M10x1.5P	68	26	39	14	144
66890-08	MC08	250	65	20	160	55	6	4-M12x1.75P	82	28	43	17	174
66890-10	MC10	310	72	22	200	70	6	4-M14x2P	93	32	50	21	218
66890-12	MC12	380	85	25	260	100	7	4-M16x2P	118	40	56	23	274

Order No.	Model	N	P	Q	R	S	Max.Gripping Diameter		N.W.
							O.D.Clamping	I.D.Clamping	
66890-06	MC06	165	144	165	66	18	Ø4~Ø128	Ø55~Ø128	11.4kg
66890-08	MC08	200	174	200	83	18	Ø5~Ø162	Ø62~Ø162	18.6kg
66890-10	MC10	250	218	250	104	18	Ø6~Ø200	Ø72~Ø200	31.6kg
66890-12	MC12	310	274	310	135	22	Ø10~Ø265	Ø90~Ø265	56.6kg

# Lathe Machine Accessories

## 66892 TNT 2-Jaw Steel Body Chuck



### Features:

- ▶ Chuck body is made of steel to enhance safety operations for high speed machining.
- ▶ Hard jaws and soft jaws are interchangeable within those power chucks
- ▶ Can be used as a “Forming plate” for machining soft jaws.
- ▶ Chuck handle can be operated easily and smoothly.

LATHE MACHINE ACCESSORIES

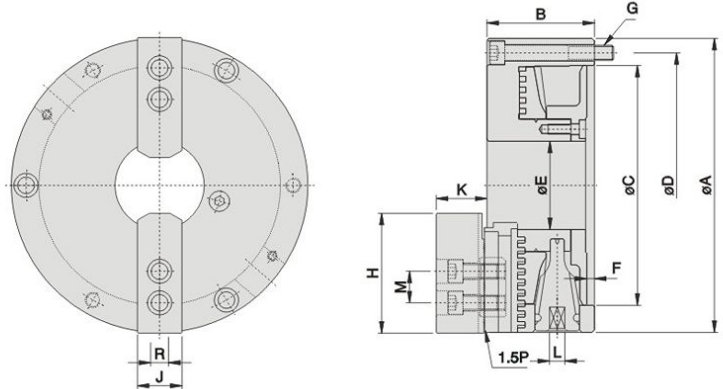

### Features in figures



Used as forming plate



Adjust for larger range



Hard Jaws



Soft Jaws



Optional Accessory

Mounting plate.

Unit:mm

Order No.	Model	A	B	C	D	E	F	G	H	J	K	L	M	R	Max. Speed (r.p.m.)	Max. Gripping Diameter		N.W.
																O.D. Clamping	I.D. Clamping	
66892-07	TNT-07	193	78	155	172	58	5	3-M10x1.5P	73	31	38	11	20	12	3200	∅ 8-∅235	∅ 66-∅235	14.4kg
66892-09	TNT-09	233	85	190	210	70	5.5	3-M12x1.75P	95	35	40	12	25	14	2800	∅ 11-∅280	∅ 85-∅280	22.3kg

**66894** NT 3-Jaw Steel Body Chuck



**Features :**

- ▶ Chuck body is made of steel to enhance safety operations for high speed machining.
- ▶ Hard jaws and soft jaws are interchangeable within those power chucks
- ▶ Can be used as a “Forming plate” for machining soft jaws.
- ▶ Chuck handle can be operated easily and smoothly.

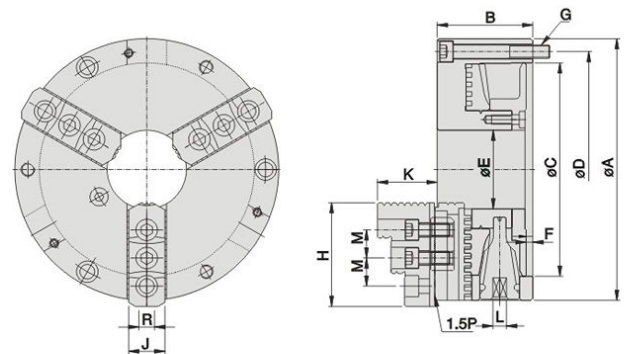

**Features in figures**



Order No.	Model	A	B	C	D	E	F	G	H	J	K	L	M	R	Max. Speed (r.p.m.)	Max. Gripping Diameter		N.W.
																O.D. Clamping	I.D. Clamping	
66894-07	NT-07	193	78	155	172	58	5	3-M10x1.5P	78	28	46	11	20	12	3200	∅ 8-∅235	∅ 66-∅235	13.1
66894-09	NT-09	233	85	190	210	70	5.5	3-M12x1.75P	92	32	52	12	25	14	2800	∅ 11-∅280	∅ 85-∅280	21.2
66894-10	NT-10	273	91	230	250	89	5.5	3-M12x1.75P	101.5	37	56	12	30	16	2400	∅ 12-∅330	∅ 92-∅330	30.5
66894-12	NT-12	310	104	260	285	105	7	3-M12x1.75P	116	47	67	14	30	21	2100	∅ 15-∅370	∅ 104-∅370	46.1

Unit:mm

# Lathe Machine Accessories

## 66896 CT Adjustable 3-Jaw Steel Body Scroll Chuck



### Features :

- ▶ Chuck body is made of steel to enhance safety operations for high speed machining.
- ▶ Adjustable 3 jaws are suitable for any shape of workpieces.

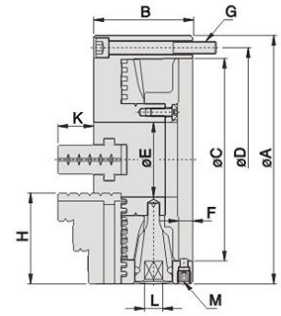
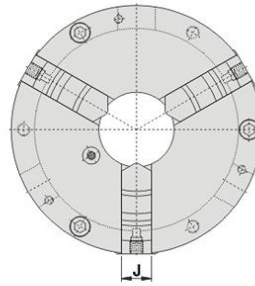

Unit:mm

Order No.	Model	A	B	C	D	E	F	G	H	J	K	L	M	Max. Speed (r.p.m.)	Max. Gripping Diameter		N.W.
															O.D. Clamping	I.D. Clamping	
66896-06	CT-06	167	75.5	130	147	45	12	3-M10x1.5P	65	22	28	10	3-M12x1.75P	4000	∅ 4-∅ 160	∅ 48-∅ 150	10.4kg
66896-07	CT-07	193	85	155	172	58	12	3-M10x1.5P	75	24	28.5	11	3-M12x1.75P	3500	∅ 4-∅ 180	∅ 56-∅ 170	12.9kg
66896-09	CT-09	233	92	190	210	70	12.5	3-M12x1.75P	85	28	33	12	3-M12x1.75P	2900	∅ 5-∅ 220	∅ 62-∅ 210	20.4kg
66896-10	CT-10	275	98	230	250	89	12.5	3-M12x1.75P	98	30	38	12	3-M12x1.75P	2500	∅ 6-∅ 260	∅ 70-∅ 250	29.3kg
66896-12	CT-12	310	111	260	285	105	14	3-M12x1.75P	110	32	45	14	3-M12x1.75P	2200	∅ 10-∅ 300	∅ 86-∅ 290	43.7kg

## 66898 FCT Adjustable 4-Jaw Steel Body Scroll Chuck



### Features :

- ▶ Chuck body is made of steel to enhance safety operations for high speed machining.
- ▶ Adjustable 4 jaws are suitable for any shape of workpieces.

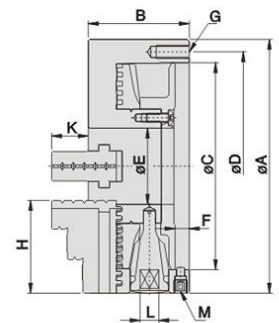
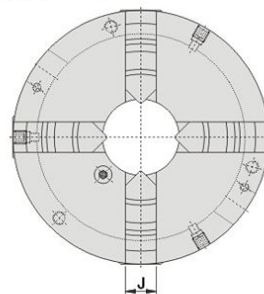

Unit:mm

Order No.	Model	A	B	C	D	E	F	G	H	J	K	L	M	Max. Speed (r.p.m.)	Max. Gripping Diameter		N.W.
															O.D. Clamping	I.D. Clamping	
66898-07	FCT-07	193	85	155	172	58	12	3-M10x1.5P	75	24	28.5	11	3-M12x1.75P	3500	∅ 4-∅ 180	∅ 56-∅ 170	13.2kg
66898-09	FCT-09	233	92	190	210	70	12.5	3-M12x1.75P	85	28	33	12	3-M12x1.75P	2900	∅ 5-∅ 220	∅ 62-∅ 210	20.7kg
66898-10	FCT-10	275	98	230	250	89	12.5	3-M12x1.75P	98	30	38	12	3-M12x1.75P	2500	∅ 6-∅ 260	∅ 70-∅ 250	29.8kg
66898-12	FCT-12	310	111	260	285	105	14	3-M12x1.75P	110	32	45	14	3-M12x1.75P	2200	∅ 10-∅ 300	∅ 86-∅ 290	44.4kg

LATHE MACHINE ACCESSORIES

**66900** TKT Powerful Adjustable 2-Jaw Steel Body Chuck



- ▶ Can be used as a “Forming plate” for machining soft jaws.
- ▶ Chuck handle can be operated easily and smoothly.
- ▶ Adjustable 2 jaws are suitable for any shape workpieces.

**Features :**

- ▶ Chuck body is made of steel to enhance safety operations for high speed machining.
- ▶ Hard jaws and soft jaws are interchangeable within those power chucks

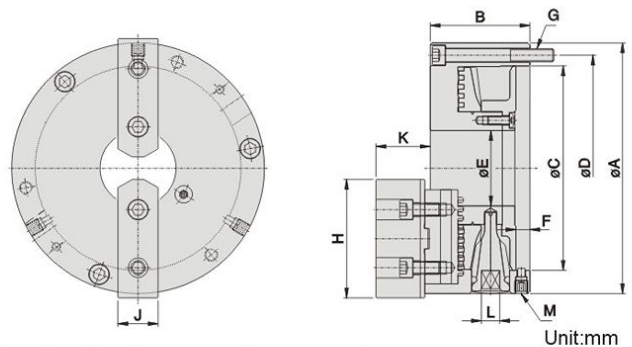

Order No.	Model	A	B	C	D	E	F	G	H	J	K	L	M	Max.Speed (r.p.m.)	Max.Gripping Diameter		N.W.
															O.D.Clamping	I.D.Clamping	
66900-06	TKT-06	167	75.5	130	147	45	12	3-M10x1.5P	73	26	40.5	10	3-M12x1.75P	4000	∅ 9-∅160	∅60-∅150	10.4kg
66900-07	TKT-07	193	85	155	172	58	12	3-M10x1.5P	95	31	49.5	11	3-M12x1.75P	3500	∅10-∅180	∅70-∅170	14.6kg
66900-09	TKT-09	233	92	190	210	70	12.5	3-M12x1.75P	110	37	50	12	3-M12x1.75P	2900	∅12-∅220	∅80-∅210	22.4kg

**66905** KT Powerful Adjustable 3-Jaw Steel Body Chuck



- ▶ Can be used as a “Forming plate” for machining soft jaws.
- ▶ Chuck handle can be operated easily and smoothly.
- ▶ Adjustable 2 jaws are suitable for any shape workpieces.

**Features :**

- ▶ Chuck body is made of steel to enhance safety operations for high speed machining.
- ▶ Hard jaws and soft jaws are interchangeable within those power chucks

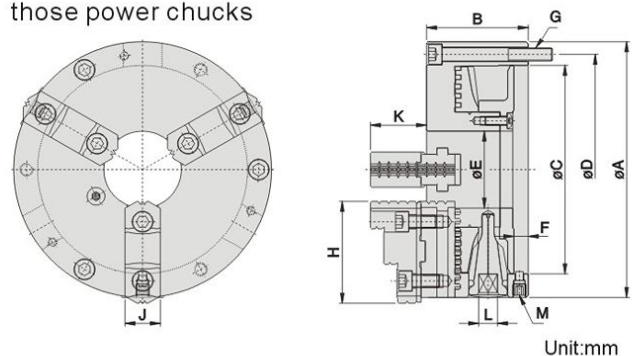

Order No.	Model	A	B	C	D	E	F	G	H	J	K	L	M	Max.Speed (r.p.m.)	Max.Gripping Diameter		N.W.
															O.D.Clamping	I.D.Clamping	
66905-06	KT-06	167	75.5	130	147	45	12	3-M10x1.5P	68	26	40	10	3-M12x1.75P	4000	∅ 8-∅160	∅55-∅150	9.7kg
66905-07	KT-07	193	85	155	172	58	12	3-M10x1.5P	82	28	43	11	3-M12x1.75P	3500	∅ 8-∅180	∅62-∅170	13.6kg
66905-09	KT-09	233	92	190	210	70	12.5	3-M12x1.75P	93	32	51	12	3-M12x1.75P	2900	∅11-∅220	∅70-∅210	21.5kg
66905-10	KT-10	275	98	230	250	89	12.5	3-M12x1.75P	102	35	54	12	3-M12x1.75P	2500	∅12-∅260	∅80-∅250	30.4kg
66905-12	KT-12	310	111	260	285	105	14	3-M12x1.75P	118	40	58	14	3-M12x1.75P	2200	∅15-∅300	∅90-∅290	45.4kg

LATHE MACHINE ACCESSORIES

# Lathe Machine Accessories

## 66912 SE04ST Stainless Steel Super Thin Chuck



### Features :

- ▶ Compact design, light, thin, short concept is suitable for measuring work.
- ▶ Rotate the chuck knob directly for gripping and loosening, no need wrench.
- ▶ Full stainless steel made, suitable for application on EDM and Wire cutting clamping.
- ▶ Jaws can be reversibly installed.

LATHE MACHINE ACCESSORIES

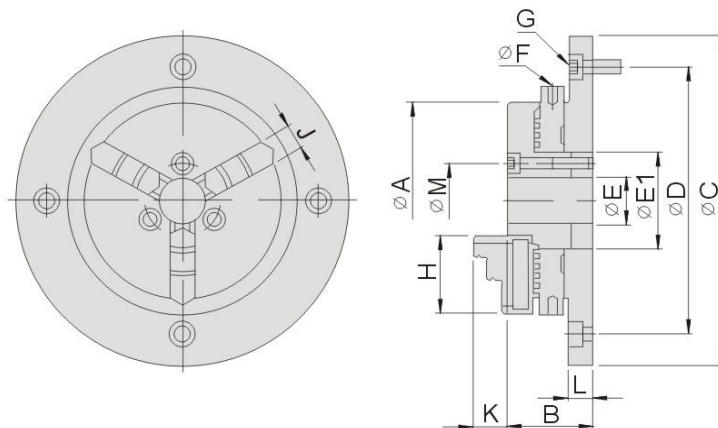

Unit:mm

Order No.	Model	A	B	C	D	E	E1	F	G
66912	SE04ST	110	39	168	140	26	51	5	4-M6x1P

Order No.	Model	H	J	K	L	M	Max.Gripping Diameter		N.W.
							O.D.Clamping	I.D.Clamping	
66912	SE04ST	42	14	19	10	40	∅1- ∅100	∅36- ∅90	4.3kg

**66915**
**SE**
**Super Thin Chuck**

**Features :**

- ▶ Compact design, light, thin, short concept is suitable for measuring work.
- ▶ Rotate the chuck knob directly for gripping and loosening, no need wrench.
- ▶ Chuck body is made of steel to enhance safety operations for high speed machining.
- ▶ Jaws can be reversibly installed.
- ▶ 2" chuck can even clamp up to the smallest size of 0.8mm.

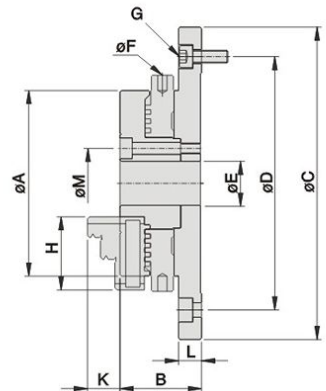
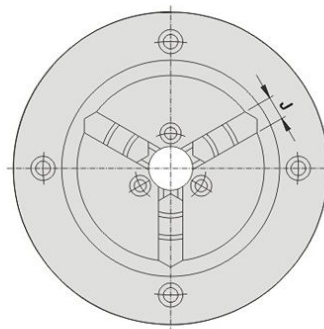

Unit:mm

Order No.	Model	A	B	C	D	E	F	G	H
<b>66915-02</b>	SE02	63	28	118	100	16	4	4-M5x0.8P	27
<b>66915-03</b>	SE03	85	37	143	116	20	4	4-M6x1P	35
<b>66915-04</b>	SE04*	110	39	168	140	26	5	4-M6x1P	42
<b>66915-05</b>	SE05	130	45	202	168	32	6	4-M8x1.25P	50
<b>66915-06</b>	SE06	160	52	248	208	50	8	4-M10x1.5P	65

Order No.	Model	J	K	L	M	Max.Gripping Diameter		N.W.
						O.D.Clamping	I.D.Clamping	
<b>66915-02</b>	SE02	8	13	8	26	ø0.8~ø63	ø23~ø58	1.2kg
<b>66915-03</b>	SE03	11	15	10.5	32	ø1~ø81	ø31~ø70	2.9kg
<b>66915-04</b>	SE04*	14	19	10	40	ø1~ø100	ø36~ø90	4.3kg
<b>66915-05</b>	SE05	16	21	11.5	49	ø1.5~ø116	ø43~ø106	6.2kg
<b>66915-06</b>	SE06	19	26	15	70	ø1.5~ø160	ø52~ø148	11.1kg

\*SE04ST has same specification as Se04

# Live Center For Lathe

## 66920 PC PC Normal Type Live Center



### Features:

- Center is made of Cr-Mo steel and hardened to HRC 58°~60°.
- Ball bearings are assembled with center.
- Suitable to medium and high speed lathes with light duty.

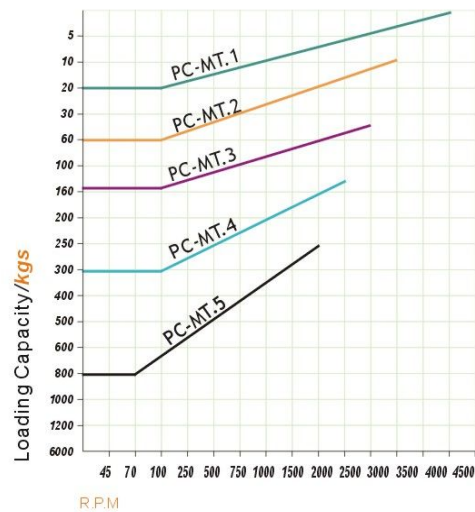
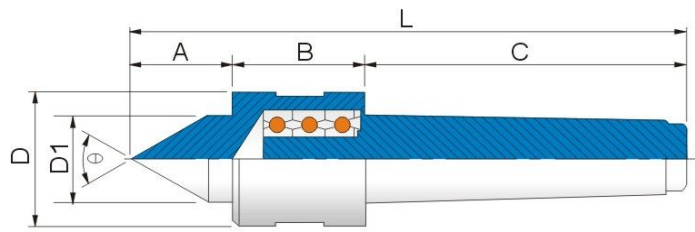

Unit:mm

Order No.	Model	A	B	C	D	D1	L	Accuracy	Max. Speed R.P.M	θ	Package LxWxH	N.W.
66920-01	PC-MT1	21	31	56	32	16	108	0.005	4500	60°	120x40x40	0.22kg
66920-02	PC-MT2	26	37	69	40	22	132		3500		140x50x50	0.42kg
66920-03	PC-MT3	32	46	86	45	26	164		3000		170x50x50	0.76kg
66920-04	PC-MT4	34	46	108	48	30	188		2500		205x60x60	1.22kg
66920-05	PC-MT5	50	62	136	68	45	248		2000		260x80x80	3.20kg





**66922** NK NK Rolling Type Live Center

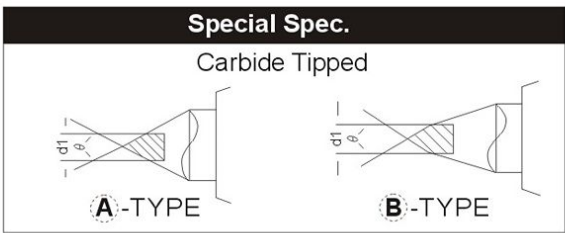
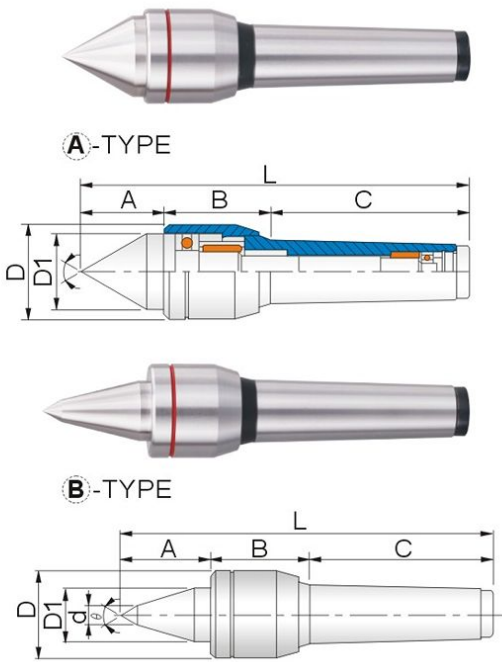

**Features:**

- Center shaft and body are made of alloy steel and hardened to HRC 60° ± 1°.
- Center is assembled with thrust bearing, needle bearing and ball bearings.
- Suitable to medium and high speed lathes with heavy loads.

NK-B type: Long nose live centers are suitable for small workpieces.

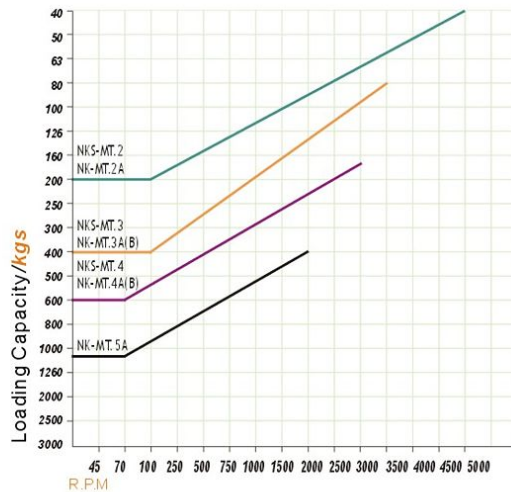

**66923** NKS NKS Rolling Type Live Center

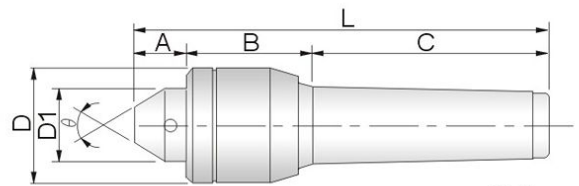

Unit:mm

Order No.	Model	A	B	C	D	D1	d	L	d1	Accuracy	Max. Speed R.P.M	θ	Package LxWxH	N.W.
66922-01	NK-MT2A	28	35	69	32	23	-	132	-	0.003	5000	60°	175x45x45	0.36kg
66922-02	NK-MT3A	36	44	86	41	35	-	166	12		3500		200x60x50	0.88kg
66922-03	NK-MT4A	41	51	108	47	40	-	200	12		3000		240x80x65	1.46kg
66922-04	NK-MT5A	54	72	136	65	52	-	262	18		2000		300x100x90	3.70kg
66922-05	NK-MT3B	46	44	86	41	25	10	176	12		3500		200x60x50	0.84kg
66922-06	NK-MT4B	55	51	108	47	32	12	214	12		3000		240x80x65	1.46kg
66923-01	NKS-MT2	22	36	69	32	25	-	127	-	0.005	5000	60°	173x102x66	0.86kg
66923-02	NKS-MT3	23	44	86	41	30	-	153	-		3500		235x130x100	1.18kg
66923-03	NKS-MT4	23	51	108	47	32	-	182	-		3000		235x130x100	1.62kg

LATH MACHINE ACCESSORIES

# Live Center For Lathe

## 66925 NCK NCK High-performance Type Live Center



**A-TYPE**

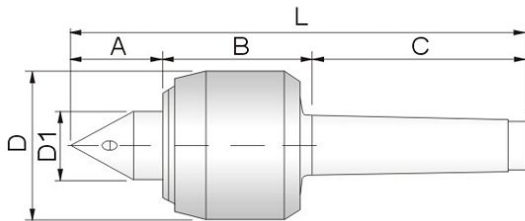

**B-TYPE**

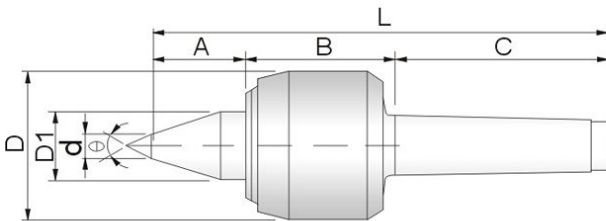

### Features:

- Center shaft and body are made of alloy steel and hardened to HRC  $60^{\circ} \pm 1^{\circ}$ .
- Center is assembled with thrust bearing, needle bearing and ball bearings.
- Applicable to CNC Lathes, waterproof design.  
NCK-B type: Long nose live centers are suitable for small workpieces.

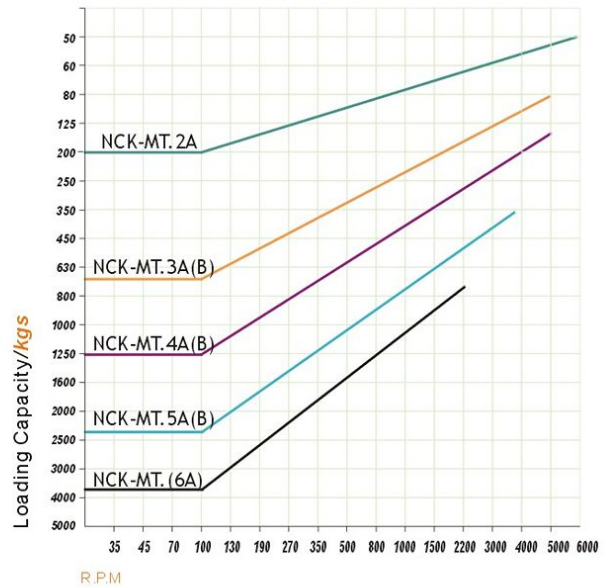

LATHES MACHINE ACCESSORIES

Unit:mm

Order No.	Model	A	B	C	D	D1	d	L	Accuracy	Max. Speed R.P.M	$\theta$	Package LxWxH	N.W.
66925-01	NCK-MT2A	20	38	69	32	13	-	127	0.003	6000	60°	180x50x40	0.38kg
66925-02	NCK-MT3A	34	61	86	58	25	-	181		5200		240x80x65	1.58kg
66925-03	NCK-MT4A	44	72	109	76	35	-	225		5000		257x100x90	3.04kg
66925-04	NCK-MT5A	60	91	136	95	45	-	287		3500		320x118x115	6.54kg
66925-05	NCK-MT6A	64	106	190	120	58	-	360		2300		425x185x180	15.0kg
66925-06	NCK-MT3B	45	61	86	58	25	10	192		5200		240x80x65	1.58kg
66925-07	NCK-MT4B	55	72	109	76	35	12	236		5000		257x100x90	3.10kg
66925-08	NCK-MT5B	70	91	136	95	45	14	297		3500		320x118x110	6.54kg

**66927** NCF NCF Heavy-load Type Live Center

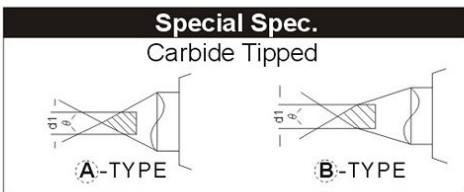
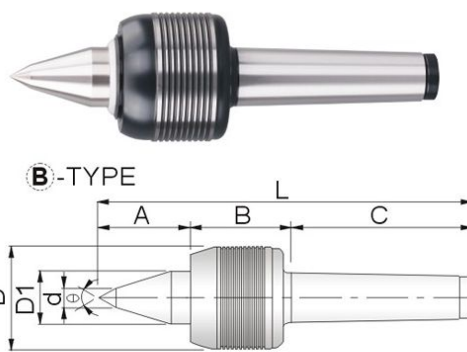
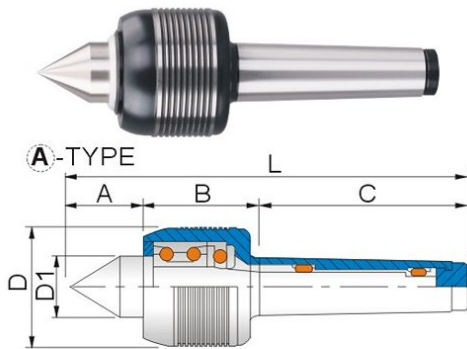

**Features:**

- Center shaft and body are made of alloy steel and hardened to HRC 60° ± 1°.
- Front end is fitted with angular contact ball bearing & thrust bearing.
- Middle & rear end are fitted with needle bearing.
- NCF-B type: Long nose live centers are suitable for small workpieces.

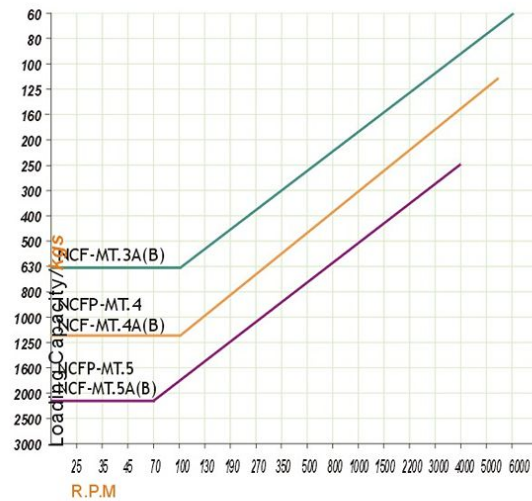

**66928** NCFP

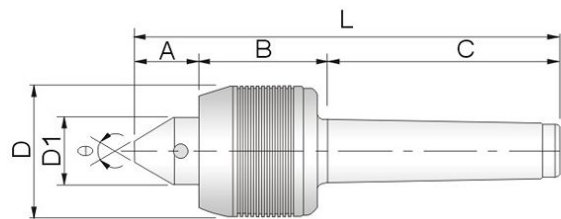

Order No.	Model	A	B	C	D	D1	d	L	d1	Accuracy	Max. Speed R.P.M	θ	Package LxWxH	N.W.
66927-01	NCF-MT3A	38	50	86	53	30	-	174	12	0.003	6000	60°	240x80x65	1.26kg
66927-02	NCF-MT4A	45	60	108	68	32	-	213	12		5500		257x100x90	2.38kg
66927-03	NCF-MT5A	52	70	136	87	40	-	258	18		4000		320x118x115	4.82kg
66927-04	NCF-MT3B	52	50	86	53	30	10	188	12		6000		240x80x65	1.28kg
66927-05	NCF-MT4B	55	60	108	68	32	12	223	12		5500		257x100x90	2.40kg
66927-06	NCF-MT5B	67	70	136	87	40	14	273	18		4000		320x118x115	4.90kg
66928-01	NCFP-MT4	29	64	108	68	32	-	201	-	0.005	5500	30°	238x132x80	2.96kg
66928-02	NCFP-MT5	37	70	136	87	40	-	243	-		4000		280x150x106	5.40kg

LATHE MACHINE ACCESSORIES

# Live Center For Lathe

## 66930 NCH NCH Heavy-load Type Live Center

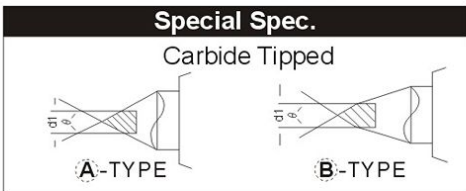
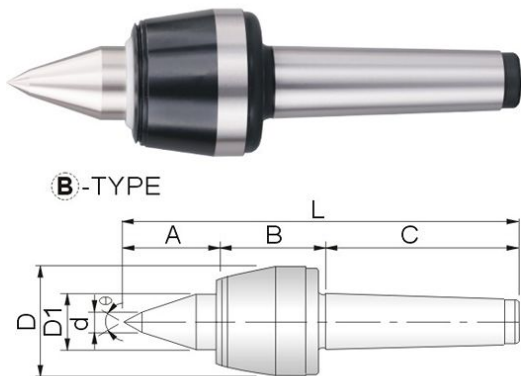
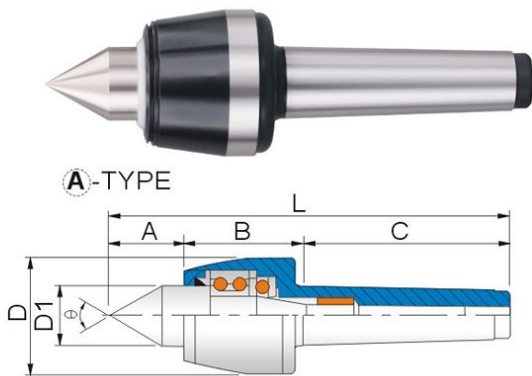

LATHES MACHINE ACCESSORIES

## 66931 NCS



**NCS-MT3 | MT4**

**NCS-MT4P | MT5P**

### Features:

- Center shaft is made of alloy steel and hardened through vacuum heat treatment to provide higher rigidity HRC 60° ± 1°.
  - Center is fitted with dual ball bearing, thrust bearing and needle roller bearing assembly.
  - Applicable to CNC Lathes, waterproof design.
- NCH-B type: Long nose live centers are suitable for small workpieces.

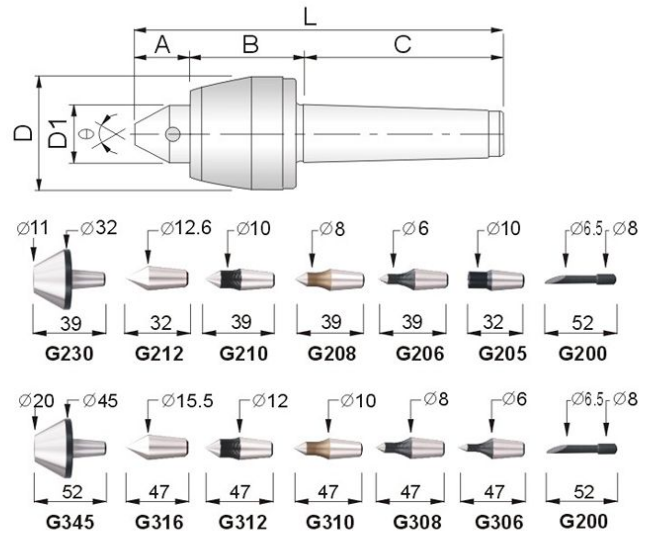
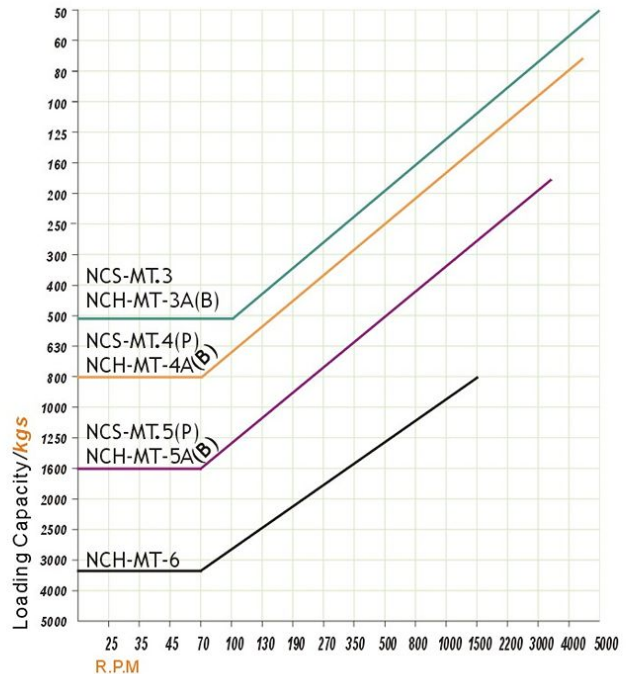

**66933** NCH NCH High-speed Type Live Center



AT -TYPE



BT -TYPE

**Features:**

- Center shaft is made of alloy steel and hardened through vacuum heat treatment to provide higher rigidity  $HRC 60^{\circ} \pm 1^{\circ}$ .
  - Center is fitted with dual ball bearing, thrust bearing and needle roller bearing assembly.
  - Applicable to CNC Lathes, waterproof design.
- NCH-BT type: Long nose live centers are suitable for small workpieces.

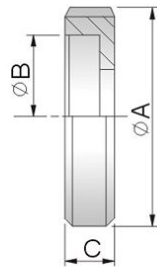

Morse Taper MT / MK	Spec (mm)		
	A	B	C
NCH-MT.4AT NCH-MT.4BT	69	M60x1.5	20
NCH-MT.5AT NCH-MT.5BT	92	M80x1.5	25

LATHE MACHINE ACCESSORIES

Order No.	Model	A	B	C	D	D1	d	L	d1	Accuracy	Max. Speed R.P.M	$\theta$	Package LxWxH	N.W.
66930-01	NCH-MT3A	39	55	86	53	30	-	180	12	0.003	5000	60°	240x80x65	1.28kg
66930-02	NCH-MT4A	42	62	108	63	30	-	208	12		4500		257x100x90	2.08kg
66930-03	NCH-MT5A	49	71	136	83	40	-	256	18		3500		320x118x115	4.42kg
66930-04	NCH-MT6A	80	110	189	128	70	-	379	-		1500		425x185x180	15.7kg
66930-05	NCH-MT3B	45	55	86	53	30	10	186	12		5000		240x80x65	1.30kg
66930-06	NCH-MT4B	52	62	108	63	30	12	218	12		4500		257x100x90	2.10kg
66930-07	NCH-MT5B	59	71	136	83	40	14	266	18		3500		320x118x115	4.54kg
66931-01	NCS-MT3	28	55	86	53	30	-	169	-		5000		235x130x100	1.50kg
66931-02	NCS-MT4	30	62	108	63	30	-	196	-		4500		235x130x100	2.18kg
66931-03	NCS-MT4P	30	62	108	63	30	-	196	-		4500		238x132x80	2.70kg
66931-04	NCS-MT5P	34	71	136	83	40	-	237	-		3500		280x150x106	5.00kg
66933-01	NCH-MT4AT	42	62	108	60	30	-	208	12		4500		257x100x90	2.46kg
66933-02	NCH-MT5AT	49	71	136	80	40	-	256	18		3500		320x118x115	5.12kg
66933-03	NCH-MT4BT	52	62	108	60	30	12	218	12		4500		257x100x90	2.52kg
66933-04	NCH-MT5BT	59	71	136	80	40	14	266	18	3500	320x118x115	5.20kg		

Unit:mm

# Live Center For Lathe

## 66935 NC NC Medium-load Type Live Center



A-TYPE

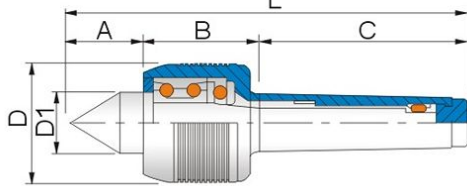

B-TYPE

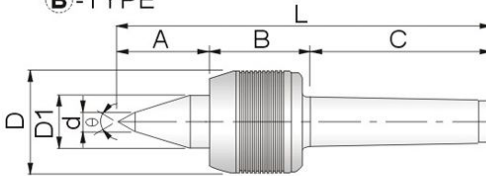

### Features:

- Center is fitted with dual ball bearing, thrust bearing and needle roller bearing assembly.
- Applicable to CNC Lathes, waterproof design.
- NC-B type: Long nose live centers are suitable for small workpieces.

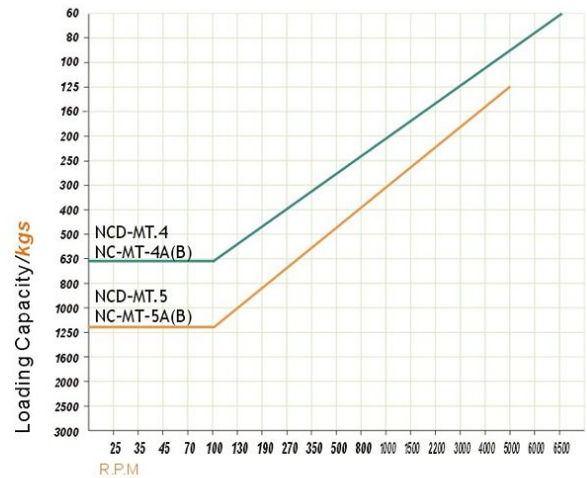

LATHES MACHINE ACCESSORIES

## 66936 NCD

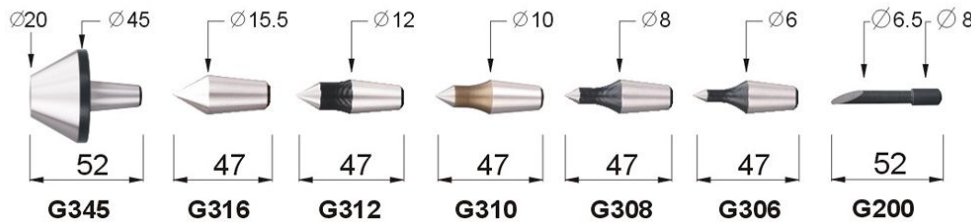
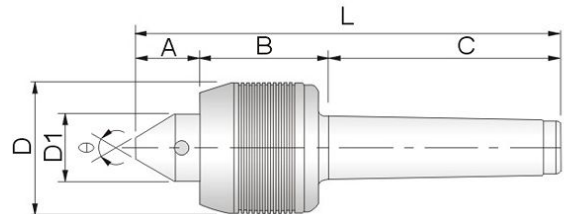

Unit:mm

Order No.	Model	A	B	C	D	D1	d	L	Accuracy	Max. Speed R.P.M	θ	Package LxWxH	N.W.
66935-01	NC-MT4A	44	55	108	53	30	-	207	0.003	6500	60°	240x80x65	1.58kg
66935-02	NC-MT5A	48	61	136	68	35	-	245		5000		300x100x90	3.28kg
66935-03	NC-MT4B	52	55	108	53	30	12	215		6500	60°	240x80x65	1.60kg
66935-04	NC-MT5B	58	61	136	68	35	14	255		5000		300x100x90	3.38kg
66936-01	NCD-MT4	33	55	108	53	30	-	196	0.005	6500	60°	238x132x80	2.32kg
66936-02	NCD-MT5	37	61	136	68	35	-	234		5000		30°	280x150x106

**66938** NCR NCR Adjustment Type Live Center



**A**-TYPE

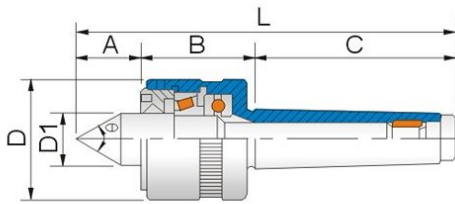

**B**-TYPE

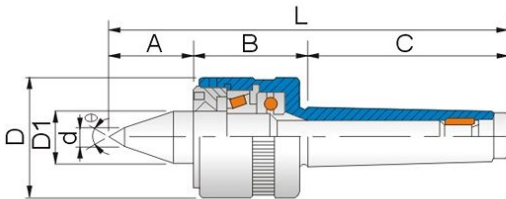

**Features:**

- Center shaft is made of alloy steel and hardened through vacuum heat treatment to provide higher rigidity HRC 60  $60^{\circ} \pm 1^{\circ}$ .
  - Center is fitted with taper roller bearing, thrust bearing and needle bearing assembly.
  - Applicable to medium and heavy loads, waterproof design.
  - The center is adjustable to reach loading capacity after using for a long period of time.
- NCR-B type: Long nose live centers are suitable for small workpieces.

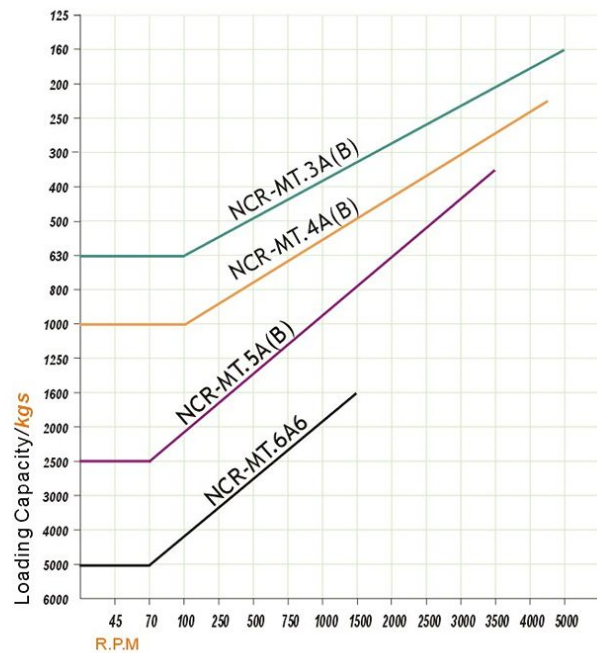

LATHE MACHINE ACCESSORIES

Unit:mm

Order No.	Model	A	B	C	D	D1	d	L	Accuracy	Max. Speed R.P.M	$\theta$	Package LxWxH	N.W.
66938-01	NCR-MT3A	37	47	86	50	25	-	170	0.003	5000	$60^{\circ}$	240x80x65	1.06kg
66938-02	NCR-MT4A	45	59	108	65	32	-	212		4500		257x100x90	2.40kg
66938-03	NCR-MT5A	50	62	136	80	40	-	248		3500		320x118x115	4.40kg
66938-04	NCR-MT6A	66	85	189	128	60	-	333		1500		425x185x180	14.2kg
66938-05	NCR-MT3B	47	47	86	50	25	10	180		5000		240x80x65	1.08kg
66938-06	NCR-MT4B	55	59	108	65	32	12	222		4500		257x100x90	2.42kg
66938-07	NCR-MT5B	60	85	136	80	40	14	263		3500		320x118x115	4.30kg

# Live Center For Lathe

**66940** SW SW Super-load Type Live Center

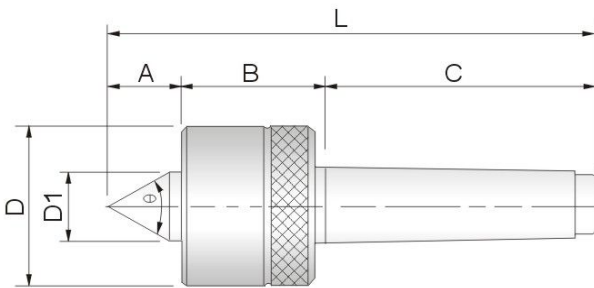

LATHE MACHINE ACCESSORIES

## Features:

- Center shaft is made of alloy steel and hardened through vacuum heat treatment to provide higher rigidity HRC  $60^{\circ} \pm 1^{\circ}$ .
- Applicable to medium and heavy loads, waterproof design.

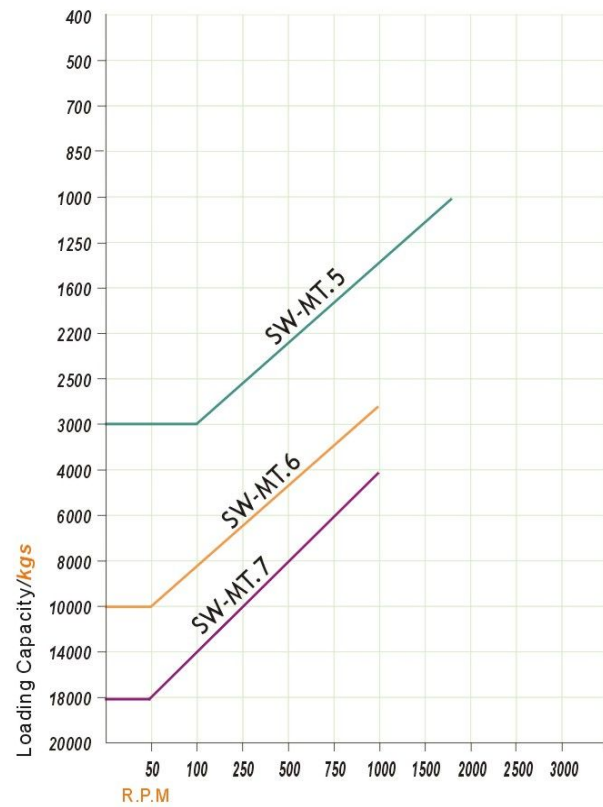

Unit:mm

Order No.	Model	A	B	C	D	D1	L	Accuracy	Max. Speed R.P.M	$\theta$	Package LxWxH	N.W.
66940-01	SW-MT5	52	82	135	98	50	269	0.005	1800	60°	340x140x120	7.5kg
66940-02	SW-MT6	74	116	190	148	70	380	0.008	1000		425x185x180	22kg
66940-03	SW-MT7	106	127	260	196	90	493				530x242x235	41kg
66940-04	SW-MT-80#	106	127	200	196	90	433				530x242x235	39kg



**66942** NCP Super High-speed Water-proof Type

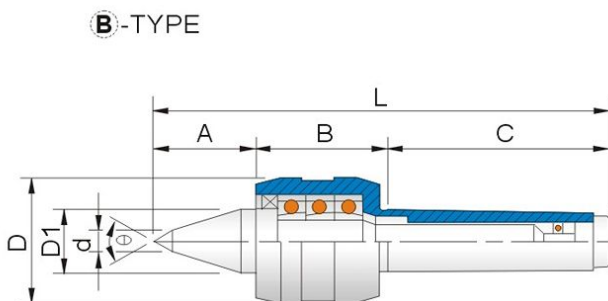
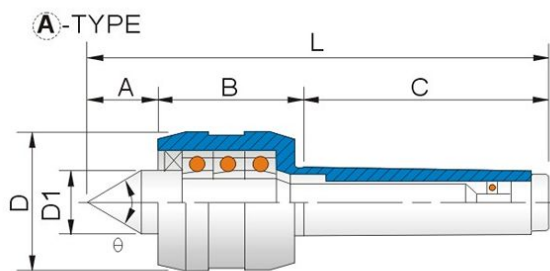

**Features:**

- Center is fitted with precision angular contact ball bearing and the combination of needle bearing and ball bearing.
- Applicable to CNC Lathes, waterproof design.  
NCP-B type: Long nose live centers are suitable for small workpieces.

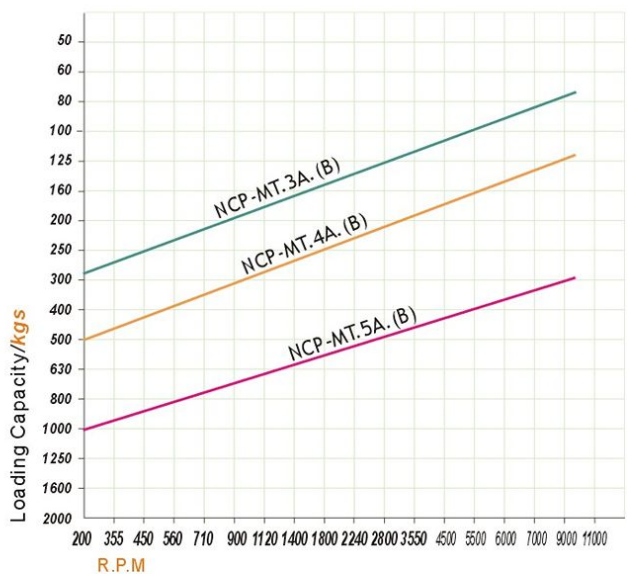

LATHE MACHINE ACCESSORIES

Order No.	Model	A	B	C	D	D1	d	L	Accuracy	Max. Speed R.P.M	θ	Package LxWxH	N.W.
66942-01	NCP-MT3A	38	58	86	48	30	-	182	0.003	10000	60°	240x80x65	1.14kg
66942-02	NCP-MT4A	45	65	108	62	32	-	215				257x100x90	2.20kg
66942-03	NCP-MT5A	50	70	136	72	40	-	256		8000		300x100x90	3.70kg
66942-04	NCP-MT3B	48	58	86	48	30	10	192		10000		240x80x65	1.18kg
66942-05	NCP-MT4B	52	65	108	62	32	12	225				257x100x90	2.24kg
66942-06	NCP-MT5B	60	70	136	72	40	14	266		8000		300x100x90	3.74kg

Unit:mm

# Live Center For Lathe

**66944**

BC

BC Bull Nose Center Type Live Center



## Features:

- ▶ The tip of bull nose center uses Cr-Mo steel and hardened to HRC  $60^{\circ} \pm 1^{\circ}$ .
- ▶ The center is fitted with a combination of taper roller bearing and ball bearings.
- ▶ Applicable to pipes turning.

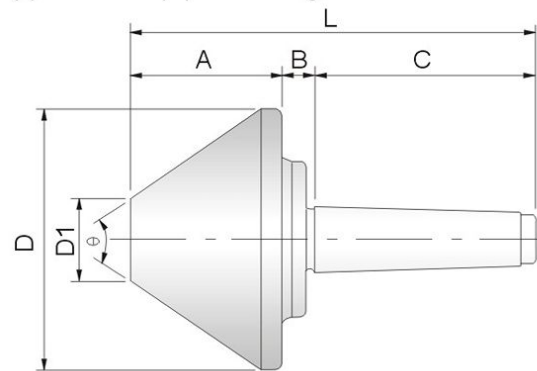

Unit:mm

Order No.	Model	A	B	C	D	D1	L	Accuracy	Max R.P.M	Load weight at 100 RPM	$\theta$	Package LxWxH	N.W.			
66944-01A	BC50-MT2	42	23	69	52	12	134	0.005	4000	200kg	$60^{\circ}$	205x60x60	0.72kg			
66944-01	BC63-MT2	46	17	69	63	12	132					195x86x86	0.94kg			
66944-02A	BC50-MT3	42	23	86	52	12	151					205x60x60	0.84kg			
66944-02	BC63-MT3	46	17	86	63	12	149					195x86x86	1.08kg			
66944-03	BC78-MT3	52	18	86	78	15	156					3300	400kg	$70^{\circ}$	195x86x86	1.56kg
66944-04	BC106-MT3	59	16	86	106	25	161					3000	500kg	$75^{\circ}$	220x120x120	2.66kg
66944-05A	BC50-MT4	42	23	108	52	12	173		4000	200kg	$70^{\circ}$	205x60x60	1.13kg			
66944-05	BC63-MT4	46	17	108	63	12	171					195x86x86	1.38kg			
66944-06	BC78-MT4	52	18	108	78	15	178					3300	400kg	$75^{\circ}$	195x86x86	1.88kg
66944-07	BC106-MT4	59	16	108	106	25	183					3000	500kg		220x120x120	2.96kg
66944-08	BC128-MT4	73	12	108	128	40	193					2000	650kg		140x140x240	4.84kg
66944-09	BC156-MT4	88	12	108	156	45	208					0.008	1900	800kg	$70^{\circ}$	170x170x260
66944-10	BC206-MT4	98	12	108	206	81	218	1500	1300kg	285x285x360	15.0kg					
66944-11	BC258-MT4	107	13	108	258	92	228	1200	2000kg	$80^{\circ}$	285x285x360		22.0kg			
66944-12A	BC106-MT5	59	16	136	106	25	211	0.005	3000	500kg	$75^{\circ}$	220x120x120	3.86kg			
66944-12	BC128-MT5	73	12	136	128	40	221		2000	650kg		140x140x240	5.70kg			
66944-13	BC156-MT5	88	12	136	156	45	236	0.008	1900	800kg	$70^{\circ}$	170x170x260	8.54kg			
66944-14	BC206-MT5	98	12	136	206	81	246		1500	1600kg		285x285x360	16.0kg			
66944-15	BC258-MT5	107	13	136	258	92	256		1200	2200kg		$80^{\circ}$	285x285x360	25.0kg		
66944-16	BC306-MT5	107	30	136	306	120	273	0.01	1000	3000kg	$90^{\circ}$	340x340x360	37.0kg			
66944-17	BC206-MT6	98	12	190	206	81	300	0.008	1500	2000kg	$70^{\circ}$	285x285x360	20.0kg			
66944-18	BC258-MT6	107	13	190	258	92	310		1200	2500kg		$80^{\circ}$	285x285x360	29.0kg		
66944-19	BC306-MT6	107	30	190	306	120	327		0.01	1000		3000kg	$90^{\circ}$	340x340x360	40.0kg	



LATHES MACHINE ACCESSORIES

### Features:

- ▶ Suitable for Lathes, CNC Lathes.  
The auto adjustable transmission center is suitable for the asperities of workpieces.
- ▶ 5T & 6T design on end surface is able to adjust the stress point so that the workpieces will be done evenly.
- ▶ Inside structure of the center is comprised of PU. It is nearly free of breakdown, and is durable and easy to repair.

Unit:mm

Order No.	Model	Center Shaft Size	Outer Dia.	Working Range	Package LxWxH	N.W.
<b>66945-01</b>	NHD-31 MT4	∅5	∅16	∅12~∅20	220X90X80	1.76kg
<b>66945-02</b>	NHD-32 MT4	∅9	∅25	∅18~∅35	220X90X80	2.30kg
<b>66945-03</b>	NHD-33 MT4	∅14	∅39	∅30~∅55	230X110X100	2.94kg
<b>66945-04</b>	NHD-34 MT4	∅18	∅53	∅40~∅70	230X110X100	4.14kg
<b>66945-05</b>	NHD-33 MT5	∅14	∅39	∅30~∅55	230X110X100	3.16kg
<b>66945-06</b>	NHD-34 MT5	∅18	∅53	∅40~∅70	230X110X100	4.40kg

# Live Center For Lathe

## 66946 Live Center(parts)

NCS-MT3 / MT4  
NKS-MT2 / MT3 / MT4

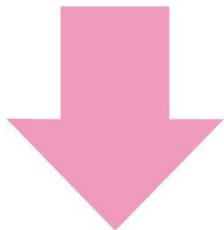

Order No.	Model
66946-01	G230
66946-02	G212
66946-03	G210
66946-04	G208
66946-05	G206
66946-06	G205
66946-07	G200

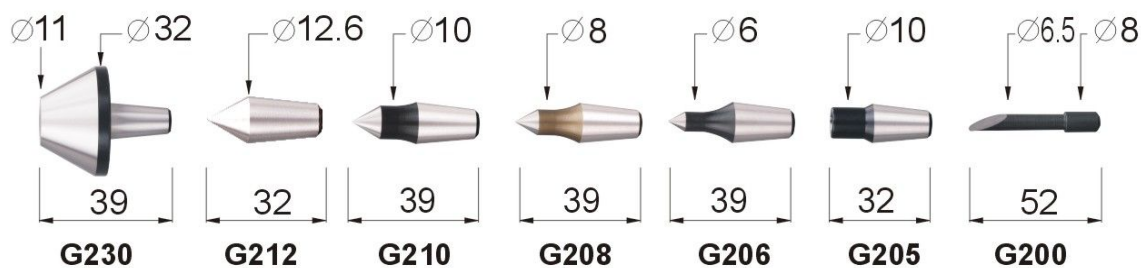

LATHES MACHINE ACCESSORIES

## 66948 Live Center(parts)

NCS-MT4P / MT5P  
NCD/NCFP-MT4 / MT5

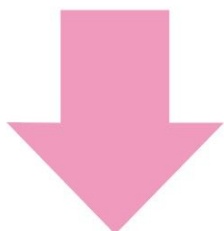

Order No.	Model
66948-01	G345
66948-02	G316
66948-03	G312
66948-04	G310
66948-05	G308
66948-06	G306

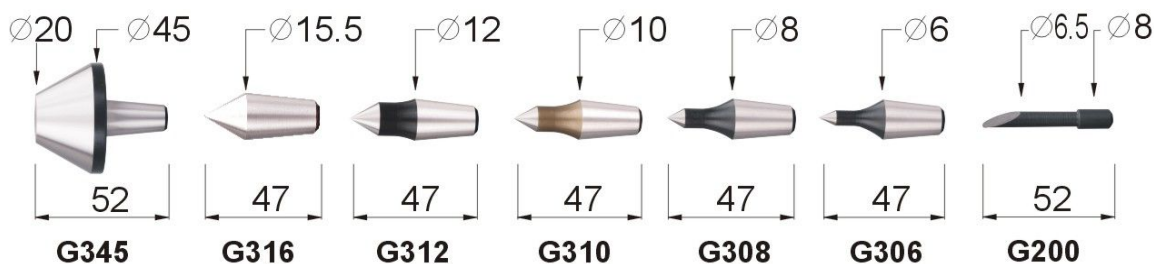

**66949** DC Driving Center



**Features:**

- ▶ Suitable for grinding shaft.
- ▶ Simple setup, increase efficiency.

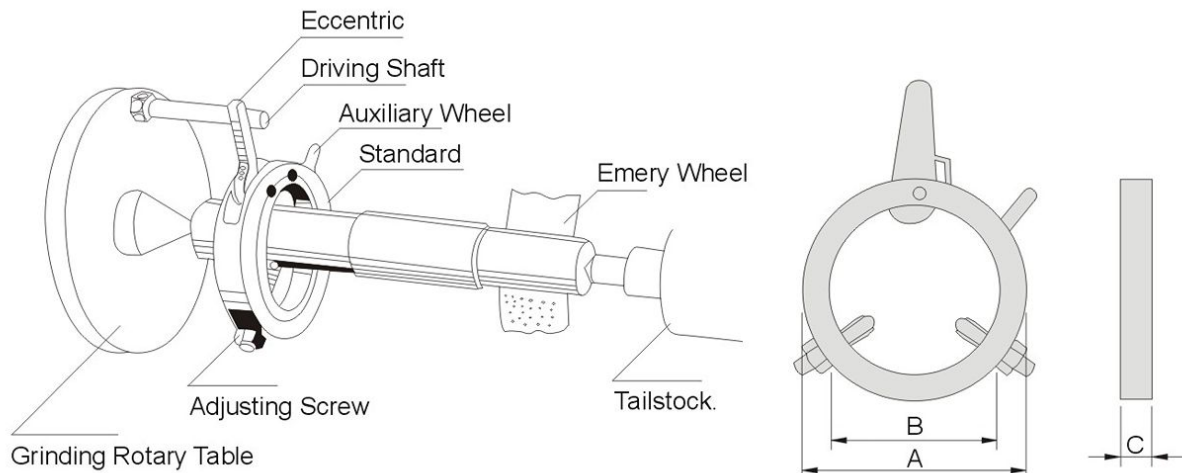

LATHES MACHINE ACCESSORIES

Unit:mm

Order No.	Model	Working Range	A±2	B±2	C±2	N.W.
66949-01	DC-13	∅6~∅14	36	18	9	0.06kg
66949-02	DC-22	∅13~∅24	48	28	9	0.08kg
66949-03	DC-30	∅20~∅33	58	38	11	0.12kg
66949-04	DC-40	∅31~∅42	68	48	11	0.14kg
66949-05	DC-50	∅35~∅50	78	58	11	0.16kg
66949-06	DC-60	∅40~∅62	89	68	11	0.18kg
66949-07	DC-80	∅60~∅80	119	88	13	0.46kg
66949-08	DC-100	∅80~∅100	140	109	13	0.54kg

# Live Center For Lathe

## 66950 SMT Solid Centers Of Medium Carbon Steel

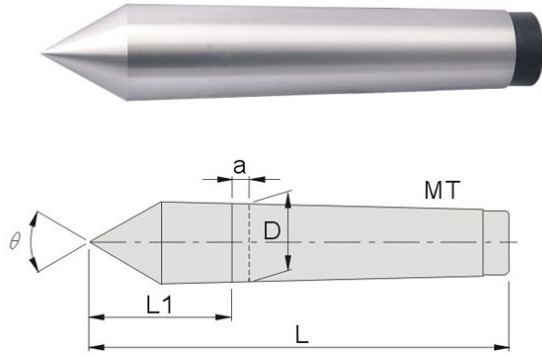

### Features:

- ▶ Made of S45C with heat treatment.
- ▶ Precision ground.
- ▶ Suitable for grinding and lathe machines.
- ▶ Morse Taper complies with DIN806 standard.

Unit:mm

Order No.	Model	Morse Taper MT	D	a	L1	L	Accuracy	θ
66950-01	SMT1	MT1	12.065	3.5	25	82	0.005	60°
66950-02	SMT2	MT2	17.780	5	31	100	0.005	60°
66950-03	SMT3	MT3	23.825	5	39	125	0.005	60°
66950-04	SMT4	MT4	31.267	6.5	46	155	0.005	60°
66950-05	SMT5	MT5	44.399	6.5	64	200	0.005	60°
66950-06	SMT6	MT6	63.348	8	80	270	0.005	60°

LATHE MACHINE ACCESSORIES

## 66951 SHMT Half-side Solid Centers Of Medium Carbon Steel

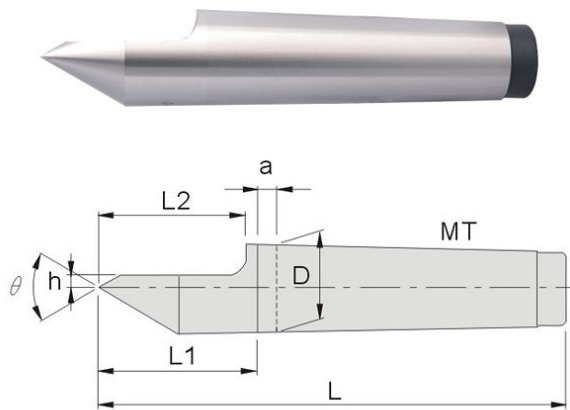

### Features:

- ▶ Made of S45C with heat treatment.
- ▶ Precision ground.
- ▶ Suitable for grinding and lathe machines.
- ▶ Morse Taper complies with DIN806 standard.

Unit:mm

Order No.	Model	Morse Taper MT	D	h	a	L1=L2	L	Accuracy	θ
66951-01	SHMT1	MT1	12.065	4	3.5	25	82	0.005	60°
66951-02	SHMT2	MT2	17.780	4	5	31	100	0.005	60°
66951-03	SHMT3	MT3	23.825	5	5	39	125	0.005	60°
66951-04	SHMT4	MT4	31.267	6	6.5	46	155	0.005	60°
66951-05	SHMT5	MT5	44.399	8	6.5	64	200	0.005	60°
66951-06	SHMT6	MT6	63.348	10	8	80	270	0.005	60°

**66952** CMT Solid Centers Of Carbide Tipped

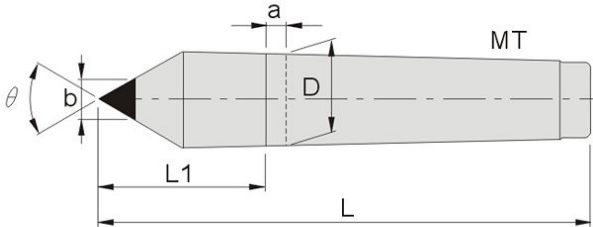

**Features:**

- ▶ Made of S45C with heat treatment.
- ▶ Precision ground.
- ▶ Suitable for grinding and lathe machines.
- ▶ Morse Taper complies with DIN806 standard.

Unit:mm

Order No.	Model	Morse Taper MT	D	a	b	L1	L	Accuracy	θ
66952-01	CMT2C06	MT2	17.780	5	6	31	100	0.005	60°
66952-02	CMT3C08	MT3	23.825	5	8	39	125	0.005	60°
66952-03	CMT4C10	MT4	31.267	6.5	10	46	155	0.005	60°
66952-04	CMT5C14	MT5	44.399	6.5	14	64	200	0.005	60°
66952-05	CMT6C18	MT6	63.348	8	18	80	270	0.005	60°

**66953** CHMT Half-side Solid Centers Of Carbide Tipped

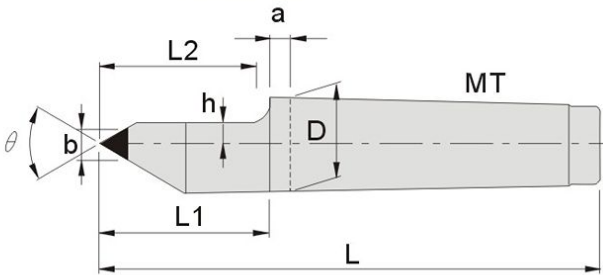

**Features:**

- ▶ Made of S45C with heat treatment.
- ▶ Precision ground.
- ▶ Suitable for grinding and lathe machines.
- ▶ Morse Taper complies with DIN806 standard.

Unit:mm

Order No.	Model	Morse Taper MT	D	a	b	h	L1=L2	L	Accuracy	θ
66953-01	CHMT1C06	MT1	12.065	3.5	6	4	25	82	0.005	60°
66953-02	CHMT2C06	MT2	17.780	5	6	4	31	100	0.005	60°
66953-03	CHMT3C06	MT3	23.825	5	6	4	39	125	0.005	60°
66953-04	CHMT3C08	MT3	23.825	5	8	5	39	125	0.005	60°
66953-05	CHMT3C10	MT3	23.825	5	10	6	39	125	0.005	60°
66953-06	CHMT4C06	MT4	31.267	6.5	6	4	46	155	0.005	60°
66953-07	CHMT4C10	MT4	31.267	6.5	10	6	46	155	0.005	60°
66953-08	CHMT4C14S	MT4	31.267	6.5	14	3.7	46	155	0.005	60°
66953-09	CHMT4C14	MT4	31.267	6.5	14	8	46	155	0.005	60°
66953-10	CHMT5C14	MT5	44.399	6.5	14	8	64	200	0.005	60°
66953-11	CHMT6C18	MT6	63.348	8	18	10	80	270	0.005	60°

LATHE MACHINE ACCESSORIES

# Live Center For Lathe

**66954**

CLMT

Extension Solid Centers Of Carbide Tipped

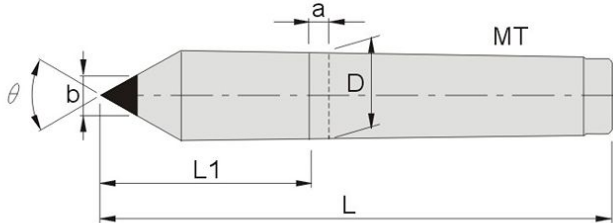

## Features:

- ▲ Made of S45C with heat treatment.
- ▲ Precision ground.
- ▲ Suitable for grinding and lathe machines.
- ▲ Morse Taper complies with DIN806 standard.

Unit:mm

Order No.	Model	Morse Taper MT	D	a	b	L1	L	Accuracy	$\theta$
66954-01	CLMT1C06	MT1	12.065	3.5	6	41	98	0.005	60°
66954-02	CLMT2C08	MT2	17.780	5	8	49	118	0.005	60°
66954-03	CLMT3C10	MT3	23.825	5	10	66	152	0.005	60°
66954-04	CLMT4C10	MT4	31.267	6.5	10	87	196	0.005	60°
66954-05	CLMT4C14	MT4	31.267	6.5	14	87	196	0.005	60°
66954-06	CLMT5C18	MT5	44.399	6.5	18	94	230	0.005	60°
66954-07	CLMT6C30	MT6	63.348	8	30	115	305	0.005	60°

**66955**

CRMT

Extension Half-side Solid Centers Of Carbide Tipped

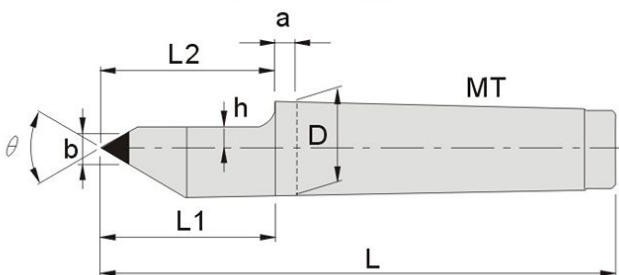

## Features:

- ▲ Made of S45C with heat treatment.
- ▲ Precision ground.
- ▲ Suitable for grinding and lathe machines.
- ▲ Morse Taper complies with DIN806 standard.

Unit:mm

Order No.	Model	Morse Taper MT	D	a	b	h	L1	L2	L	Accuracy	$\theta$
66955-01	CRMT1C06	MT1	12.065	3.5	6	4	41	41	98	0.005	60°
66955-02	CRMT2C06S	MT2	17.780	5	6	1.5	49	39	118	0.005	60°
66955-03	CRMT2C06	MT2	17.780	5	6	4	49	39	118	0.005	60°
66955-04	CRMT2C08	MT2	23.825	5	8	2.5	49	39	118	0.005	60°
66955-05	CRMT3C06S	MT3	23.825	5	6	1.5	49	38	152	0.005	60°
66955-06	CRMT3C06	MT3	23.825	5	6	4	66	38	152	0.005	60°
66955-07	CRMT3C08S	MT3	23.825	5	8	2.5	49	38	152	0.005	60°
66955-08	CRMT3C08	MT3	23.825	5	8	5	66	38	152	0.005	60°
66955-09	CRMT3C10	MT3	23.825	5	10	4	49	38	152	0.005	60°
66955-10	CRMT4C06	MT4	31.267	6.5	14	1.5	87	69	196	0.005	60°
66955-11	CRMT4C08	MT4	31.267	6.5	14	2.5	87	69	196	0.005	60°
66955-12	CRMT4C10	MT4	31.267	6.5	10	6	87	69	196	0.005	60°
66955-13	CRMT4C14S	MT4	31.267	6.5	14	3.7	87	69	196	0.005	60°
66955-14	CRMT4C14	MT4	31.267	6.5	14	8	87	69	196	0.005	60°
66955-15	CRMT5C14	MT5	44.399	6.5	14	8	94	79	230	0.005	60°
66955-16	CRMT6C18	MT6	63.348	8	18	10	115	80	305	0.005	60°

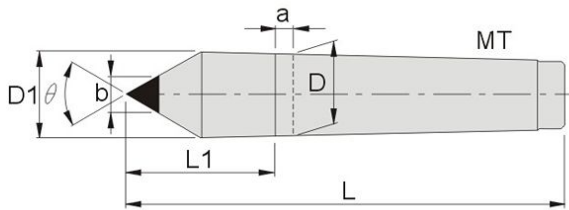

**Features:**

- ▲ Made of S45C with heat treatment.
- ▲ Precision ground.
- ▲ Suitable for grinding and lathe machines.
- ▲ Morse Taper complies with DIN806 standard.

Unit:mm

Order No.	Model	Morse Taper MT	D	D1	a	b	L1	L	Accuracy	$\theta$
66956-01	CAMT1C08	MT1	12.065	-	3.5	8	29	86	0.005	60°
66956-02	CAMT1C10	MT1	12.065	-	3.5	10	29	86	0.005	60°
66956-03	CAMT2C10	MT2	17.780	-	5	10	31	100	0.005	60°
66956-04	CAMT2C12	MT2	17.780	-	5	12	31	100	0.005	60°
66956-05	CAMT2C14	MT2	17.780	24	5	14	47	117	0.005	60°
66956-06	CAMT2C18	MT2	17.780	28	5	18	51	120	0.005	60°
66956-07	CAMT2C20	MT2	17.780	28	5	20	53	122	0.005	60°
66956-08	CAMT2C30	MT2	17.780	31.6	5	31.6	52	122	0.005	60°
66956-09	CAMT3C14	MT3	23.825	-	5	14	42	128	0.005	60°
66956-10	CAMT3C14S	MT3	23.825	-	5	14	67	155	0.005	60°
66956-11	CAMT3C18	MT3	23.825	-	5	18	46	132	0.005	60°
66956-12	CAMT3C18S	MT3	23.825	-	5	18	73	159	0.005	60°
66956-13	CAMT3C24S	MT3	23.825	24.1	5	24.1	51	137	0.005	60°
66956-14	CAMT3C24	MT3	23.825	35	5	24	68	154	0.005	60°
66956-15	CAMT3C30	MT3	23.825	40	5	30	73	159	0.005	60°
66956-16	CAMT4C18	MT4	31.267	-	6.5	18	49	158	0.005	60°
66956-17	CAMT4C18S	MT4	31.267	-	6.5	18	91	200	0.005	60°
66956-18	CAMT4C20	MT4	31.267	-	6.5	20	91	200	0.005	60°
66956-19	CAMT4C25	MT4	31.267	-	6.5	25	55	164	0.005	60°
66956-20	CAMT4C25S	MT4	31.267	-	6.5	25	97	206	0.005	60°
66956-21	CAMT4C30	MT4	31.267	48	6.5	30	58	167	0.005	60°
66956-22	CAMT4C30A	MT4	31.267	48	6.5	30	72	181	0.005	60°
66956-23	CAMT4C30B	MT4	31.267	31.6	6.5	31.6	61	170	0.005	60°
66956-24	CAMT4C30C	MT4	31.267	31.6	6.5	31.6	101	210	0.005	60°
66956-25	CAMT4C36	MT4	31.267	54	6.5	36	63	172	0.005	60°
66956-26	CAMT4C36S	MT4	31.267	54	6.5	36	77	186	0.005	60°
66956-27	CAMT4C40	MT4	31.267	58	6.5	40	73	182	0.005	60°
66956-28	CAMT4C40S	MT4	31.267	58	6.5	40	81	190	0.005	60°
66956-29	CAMT5C25	MT5	44.399	-	6.5	25	70	206	0.005	60°
66956-30	CAMT5C30	MT5	44.399	-	6.5	30	74	210	0.005	60°
66956-31	CAMT5C36	MT5	44.399	55	6.5	36	64	200	0.005	60°
66956-32	CAMT5C36S	MT5	44.399	55	6.5	36	101	237	0.005	60°
66956-33	CAMT5C40	MT5	44.399	58	6.5	40	72	208	0.005	60°
66956-34	CAMT5C40S	MT5	44.399	58	6.5	40	104	240	0.005	60°
66956-35	CAMT5C45	MT5	44.399	44.7	6.5	44.7	64	200	0.005	60°
66956-36	CAMT5C45S	MT5	44.399	44.7	6.5	44.7	94	230	0.005	60°
66956-37	CAMT6C36	MT6	63.348	-	8	36	88	278	0.005	60°
66956-38	CAMT6C40	MT6	63.348	-	8	40	88	278	0.005	60°

# Live Center For Lathe

## 66957 CVMT X-large Half-side Solid Centers Of Carbide Tipped

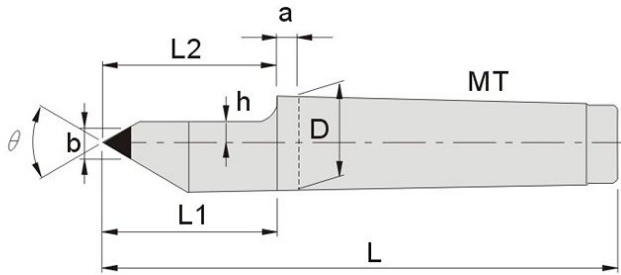

### Features:

- ▶ Made of S45C with heat treatment.
- ▶ Precision ground.
- ▶ Suitable for grinding and lathe machines.
- ▶ Morse Taper complies with DIN806 standard.

Unit:mm

Order No.	Model	Morse Taper MT	D	a	b	h	L1	L2	L	Accuracy	θ
66957-01	CVMT1C08	MT1	12.065	3.5	8	2.5	28	30	85	0.005	60°
66957-02	CVMT2C10	MT2	17.780	5	10	6	31	31	100	0.005	60°
66957-03	CVMT3C14	MT3	23.825	5	14	8	42	42	128	0.005	60°
66957-04	CVMT3C14S	MT3	23.825	5	14	8	69	55	155	0.005	60°
66957-05	CVMT3C18	MT3	23.825	5	18	10	46	46	132	0.005	60°
66957-06	CVMT3C18S	MT3	23.825	5	18	10	73	59	159	0.005	60°
66957-07	CVMT4C18	MT4	31.267	6.5	18	10	49	49	158	0.005	60°
66957-08	CVMT4C18S	MT4	31.267	6.5	18	10	91	79	200	0.005	60°
66957-09	CVMT4C25	MT4	31.267	6.5	25	13.5	55	55	164	0.005	60°
66957-10	CVMT4C25S	MT4	31.267	6.5	25	13.5	49	79	206	0.005	60°

LATHES MACHINE ACCESSORIES

## 66958 CFMT Female Solid Centers Of Carbide Tipped

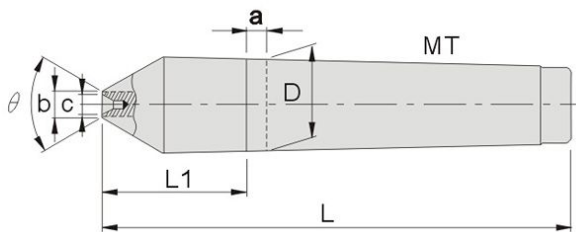

### Features:

- ▶ Made of S45C with heat treatment.
- ▶ Precision ground.
- ▶ Suitable for grinding and lathe machines.
- ▶ Morse Taper complies with DIN806 standard.

Unit:mm

Order No.	Model	Morse Taper MT	D	a	b	C	L1	L	Accuracy	θ
66958-01	CFMT1C06	MT1	12.065	3.5	6	1.5x1	20	77	0.005	60°
66958-02	CFMT2C08	MT2	17.780	5	8	1.5x1	27	96	0.005	60°
66958-03	CFMT3C08	MT3	23.825	5	8	1.5x1	33	119	0.005	60°
66958-04	CFMT4C08	MT4	31.267	6.5	8	1.5x1	43	152	0.005	60°
66958-05	CFMT4C08S	MT4	31.267	6.5	8	1.5x1	76	185	0.005	60°

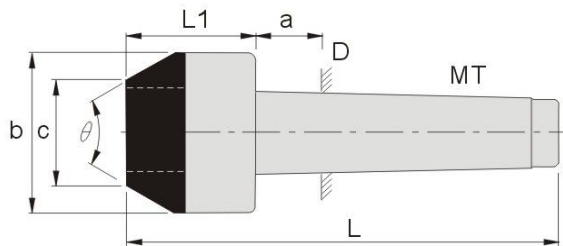

### Features:

- ▶ Made of S45C with heat treatment.
- ▶ Precision ground.
- ▶ Suitable for grinding and lathe machines.
- ▶ Morse Taper complies with DIN806 standard.

Unit:mm

Order No.	Model	Morse Taper MT	D	a	b	C	L1	L	Accuracy	θ
66959-01	CSMT3C35	MT3	23.825	5	35	16	54	140	0.005	60°
66959-02	CSMT3C35S	MT3	23.825	5	35	16	69	155	0.005	60°
66959-03	CSMT3C40	MT3	23.825	5	40	20	54	140	0.005	60°
66959-04	CSMT3C40S	MT3	23.825	5	40	20	69	155	0.005	60°
66959-05	CSMT3C50	MT3	23.825	5	50	30	54	140	0.005	60°
66959-06	CSMT3C50S	MT3	23.825	5	50	30	69	155	0.005	60°
66959-07	CSMT4C35	MT4	31.267	6.5	35	16	51	160	0.005	60°
66959-08	CSMT4C35S	MT4	31.267	6.5	35	16	66	175	0.005	60°
66959-09	CSMT4C40	MT4	31.267	6.5	40	20	51	160	0.005	60°
66959-10	CSMT4C40S	MT4	31.267	6.5	40	20	66	175	0.005	60°
66959-11	CSMT4C50	MT4	31.267	6.5	50	30	51	160	0.005	60°
66959-12	CSMT4C50S	Mt4	31.267	6.5	50	30	66	175	0.005	60°